

# Chapter 3

## Basic Bridge Terminology

### Topic 3.1 Basic Bridge Terminology

#### 3.1.1

##### Introduction

It is important to be familiar with the terminology and elementary theory of bridge mechanics and materials. This topic presents the terminology needed by inspectors to properly identify and describe the individual elements that comprise a bridge. First the major components of a bridge are introduced. Then the basic member shapes and connections of the bridge are presented. Finally, the purpose and function of the major bridge components are described in detail.

#### 3.1.2

##### NBIS Structure Length

According to the *FHWA Recording and Coding Guide for the Structure Inventory and Appraisal of the Nation's Bridges*, the structure length is measured in accordance with Item 49 as shown on Figure 3.1.1. The structure length is the length of the roadway that is supported by the bridge structure. To determine the length, measure back to back of back-walls of abutments or from paving notch to paving notch. If the location of the backs of backwalls cannot be exactly determined, inspectors can then measure the distance between the paving notches to determine structure length.

To measure the length of culverts, measure along the center line of the roadway regardless of their depth below grade. The measurements will be between the inside faces of the exterior walls. Tunnels should be measured along the center of the roadway.

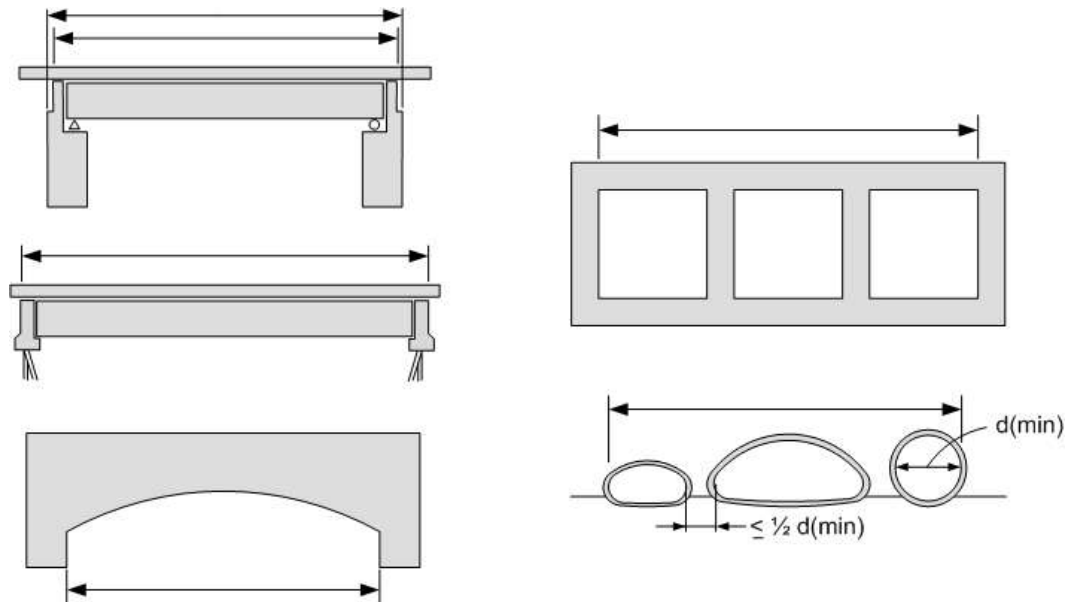
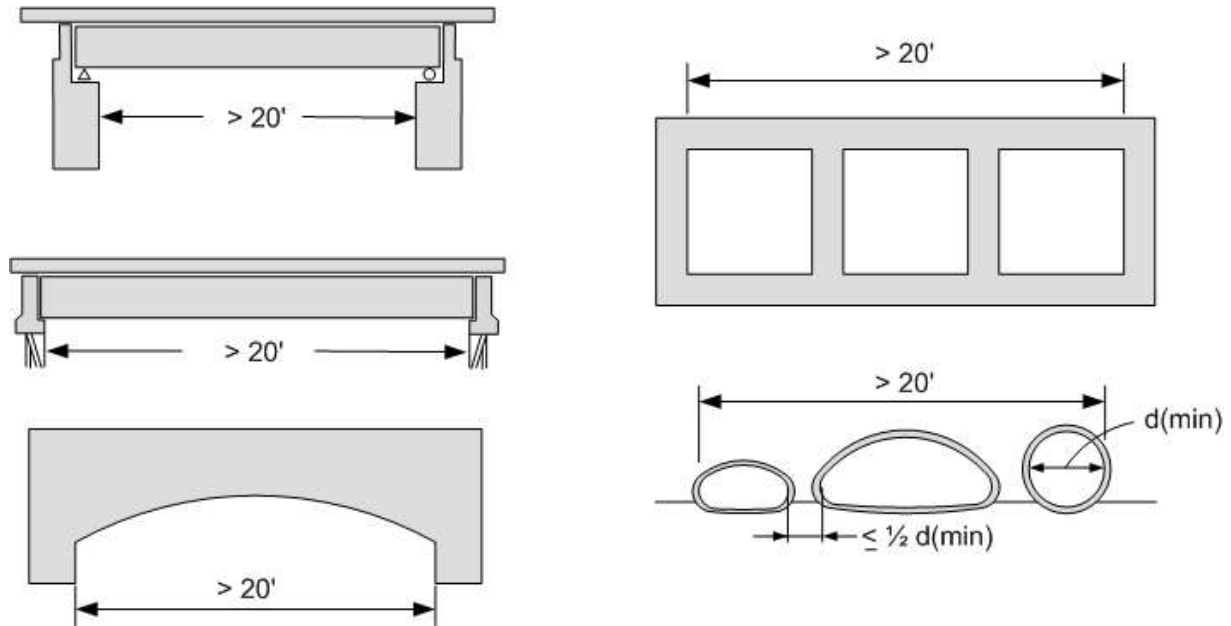


Figure 3.1.1 NBIS Structure Length

### 3.1.3

#### **NBIS Bridge Length**

The *FHWA Recording and Coding Guide for the Structure Inventory and Appraisal of the Nation's Bridges* also states, in accordance with Item 112 – NBIS Bridge Length, that the minimum length for a structure to be considered a bridge for National Bridge Inspection Standards purposes, is to be 20 feet (see Figure 3.1.2).



**Figure 3.1.2** NBIS Bridge Length (Coding Guide Item 112)

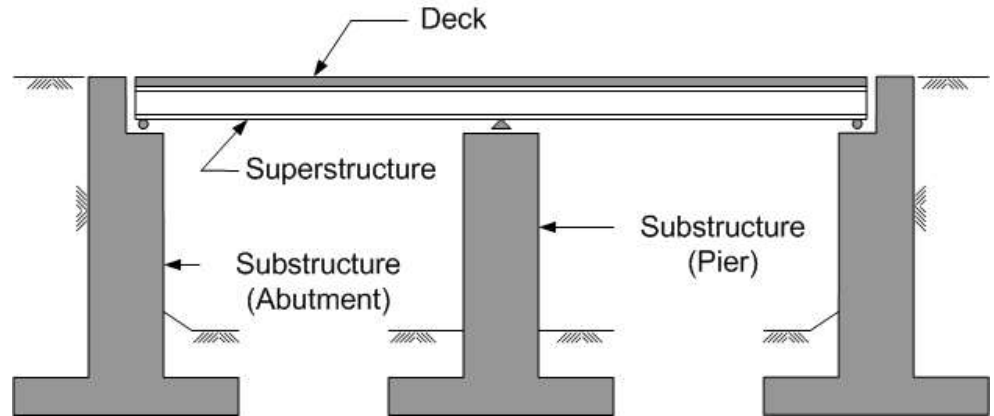
23 CFR Part 650.305 Definitions gives the definition of a bridge as it applies to the NBIS regulations: A bridge is a structure including supports erected over a depression or an obstruction, such as water, highway, or railway, and having a track or passageway for carrying traffic or other moving loads, and having an opening measured along the center of the roadway of more than 20 feet between undercopings of abutments or spring lines of arches, or extreme ends of openings for multiple boxes; it may also include multiple pipes, where the clear distance between openings is less than half of the smaller contiguous opening.

### 3.1.4

#### **Major Bridge Components**

A thorough and complete bridge inspection is dependent upon the bridge inspector's ability to identify and understand the function of the major bridge components and their elements. Most bridges can be divided into three basic parts or components (see Figure 3.1.3):

- Deck
- Superstructure
- Substructure



**Figure 3.1.3** Major Bridge Components

### 3.1.5

#### **Basic Member Shapes**

The ability to recognize and identify basic member shapes requires an understanding of the timber, concrete, and steel shapes used in the construction of bridges.

Every bridge member is designed to carry a unique combination of tension, compression, and shear. These are considered the three basic kinds of member stresses. Bending loads cause a combination of tension and compression in a member. Shear stresses are caused by transverse forces exerted on a member. As such, certain shapes and materials have distinct characteristics in resisting the applied loads. For a review of bridge loadings and member responses, see Topic 5.1.

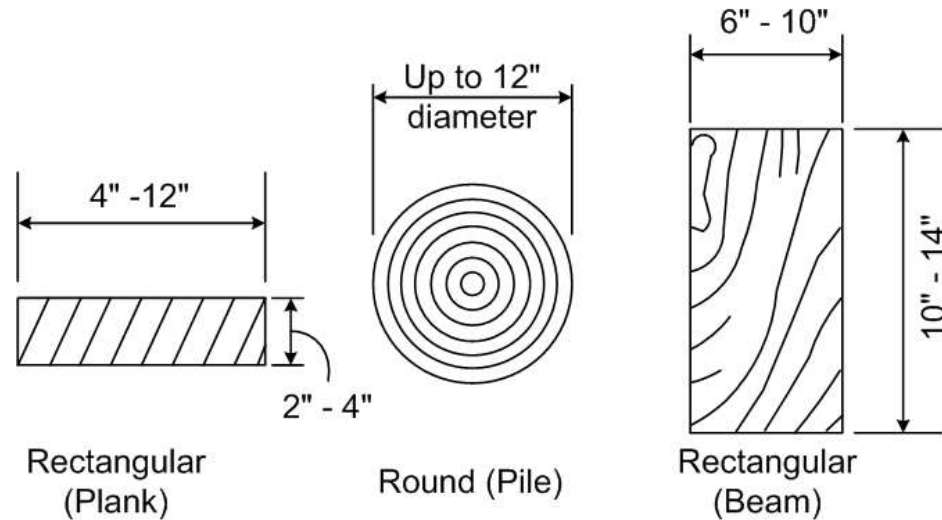
#### **Timber Shapes**

Basic shapes, properties, gradings, deficiencies, protective systems, and examination of timber are covered in detail in Topic 6.1.

Timber members are found in a variety of shapes (see Figure 3.1.4). The sizes of timber members are generally given in nominal dimensions (such as in Figures 3.1.4 and 3.1.5). However, sawn timber members are generally seasoned and surfaced from the rough sawn condition, making the actual dimension about 1/2 to 3/4 inches less than the nominal dimension.

The physical properties of timber enable it to resist both tensile and compressive stresses. Therefore, it can function as an axially-loaded or bending member. Timber bridge members are made into three basic shapes:

- Round – piles, columns, posts
- Rectangular – planks, beams, columns, piles
- Built-up shapes - beams



**Figure 3.1.4** Timber Members

### Planks

Planks are characterized by elongated, rectangular dimensions determined by the intended bridge use. Plank thickness is dependent upon the distance between the supporting points and the magnitude of the vehicle load. Common nominal or rough sawn dimensions for timber planks are 2 to 4 inches thick and 6 to 12 inches wide. Dressed lumber dimensions would be 1 ½ inches x 11 ¼ inches (see Figure 3.1.4).

Planks are most often used for bridge decks on bridges carrying light or infrequent truck traffic. Timber plank decks have been used for centuries. Timber planks are advantageous in that they are economical, lightweight, readily available, and easy to install.

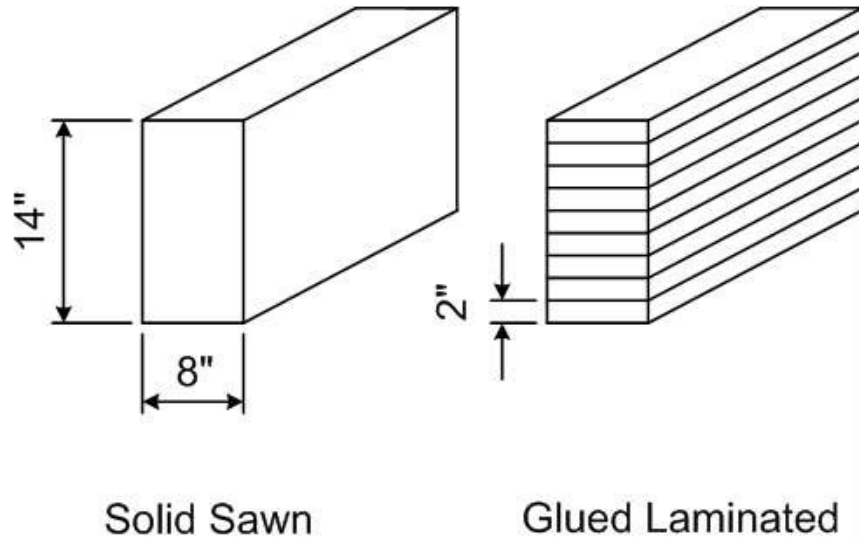
### Beams

Timber beams have more equal rectangular dimensions than do planks, and they are sometimes square. Common dimensions include 10 inch by 10 inch square timbers, and 6 inch by 14 inch rectangular timbers. Beams generally are installed with the larger dimension vertical.

As the differences in the common dimensions of planks and timber beams indicate, beams are larger and heavier than planks and can support heavier loads, as well as span greater distances. As such, timber beams are used in bridge superstructures and substructures to carry bending and axial loads.

Timbers can either be solid sawn or built-up glued-laminated (see Figure 3.1.5). Glued-laminated timbers are advantageous in that they can be fabricated from smaller, more readily available pieces. Glued lamination also allows larger rectangular members to be formed without the presence of natural deficiencies such as knots. Glued-laminated timbers are normally manufactured from well-seasoned wood and display very little shrinkage after they are fabricated.





**Figure 3.1.5** Timber Beams

### Piles/Columns

Timber can also be used for piles or columns. Piles are normally round, slender columns that support the substructure footing or partially form the substructure. Piles may be partially above ground or completely buried.

### Concrete Shapes

Basic ingredients, properties, reinforcement, deficiency, protective systems, and examination of concrete are covered in detail in Topic 6.2.



**Figure 3.1.6** Unusual Concrete Shapes

Concrete is a unique material for bridge members because it can be formed into an infinite variety of shapes (see Figure 3.1.6). Concrete members are used to carry axial and bending loads. Since bending results in a combination of compressive and tensile stresses, concrete bending members are typically reinforced with either

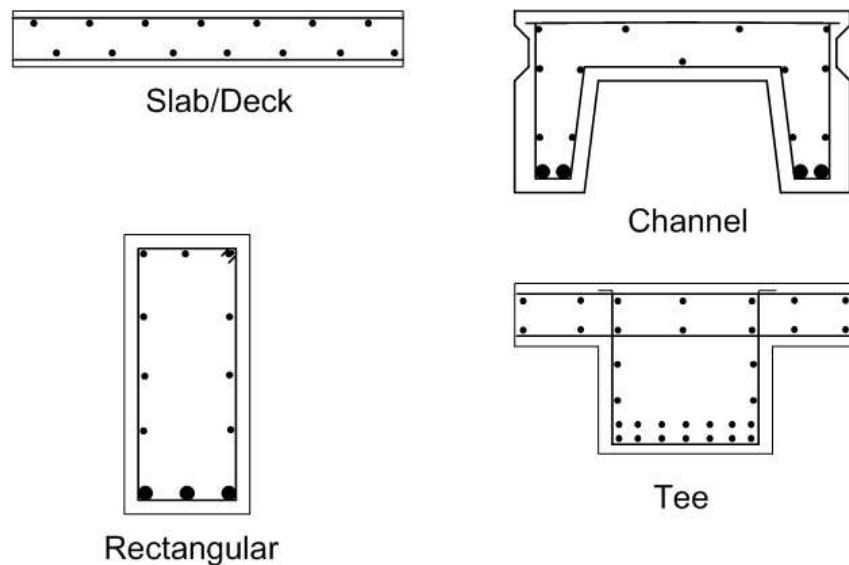
reinforcing steel bars (producing conventionally reinforced concrete) or with prestressing steel (producing prestressed concrete) in order to carry the tensile stresses in the member. Reinforcing steel is also added to increase the shear and torsion capacity of concrete members.

### Cast-in-Place Flexural Shapes

The most common shapes of reinforced concrete members are (see Figure 3.1.7):

- Slabs/Decks
- Rectangular beams
- Tee beams
- Channel beams

Bridges utilizing these shapes and mild steel reinforcement have been constructed and were typically cast-in-place (CIP). Many of the designs are obsolete, but the structures remain in service. Concrete members of this type are used for short and medium span bridges.



**Figure 3.1.7** Reinforced Concrete Shapes

On concrete decks, the concrete spans the distance between superstructure members and is generally 7 to 9 inches thick. On slab bridges, the slab spans the distance between piers or abutments, forming an integral deck and superstructure. Slab bridge elements are usually 12 to 24 inches thick.

Rectangular beams are used for both superstructure and substructure bridge elements. Concrete pier caps are commonly rectangular beams which support the superstructure.

Tee beams are generally limited to superstructure elements. Distinguished by a "T" shape, tee beams combine the functions of a rectangular stem and flange to form an integral deck and superstructure.

Channel beams are generally limited to superstructure elements. This particular

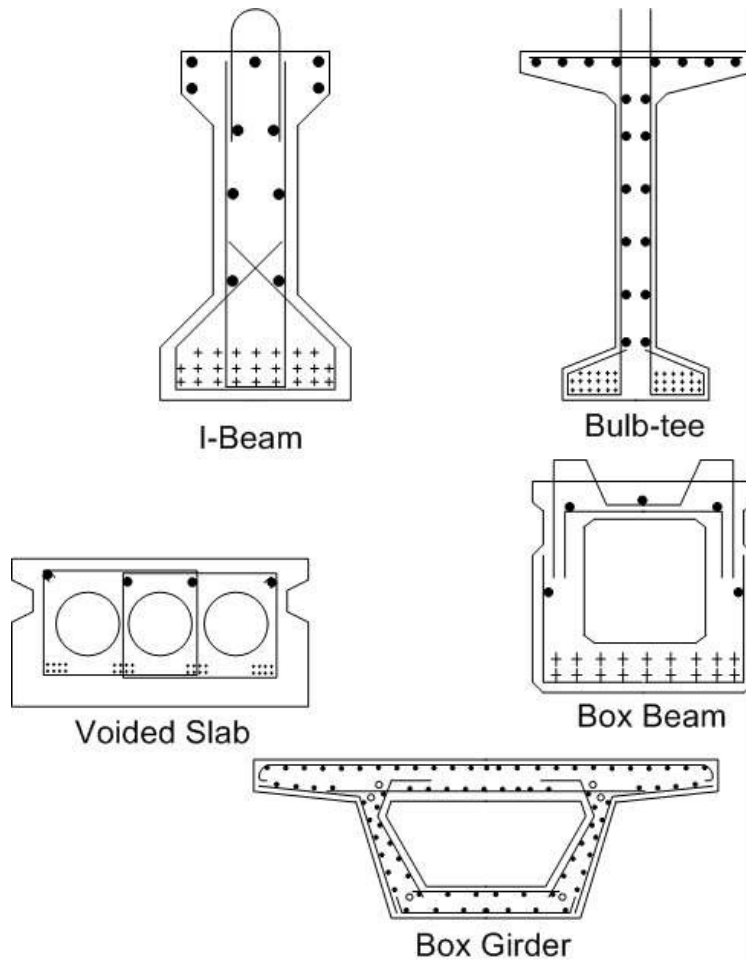
shape can be precast or cast-in-place. Channel beams are formed in the shape of a "C" and placed legs down when erected. They function as both superstructure and deck and are typically used for shorter span bridges.

### Precast Flexural Shapes

The most common shapes of prestressed concrete members are (see Figure 3.1.8):

- I-beams
- Bulb-tees
- Voided or solid slabs
- Box beams
- Box girders

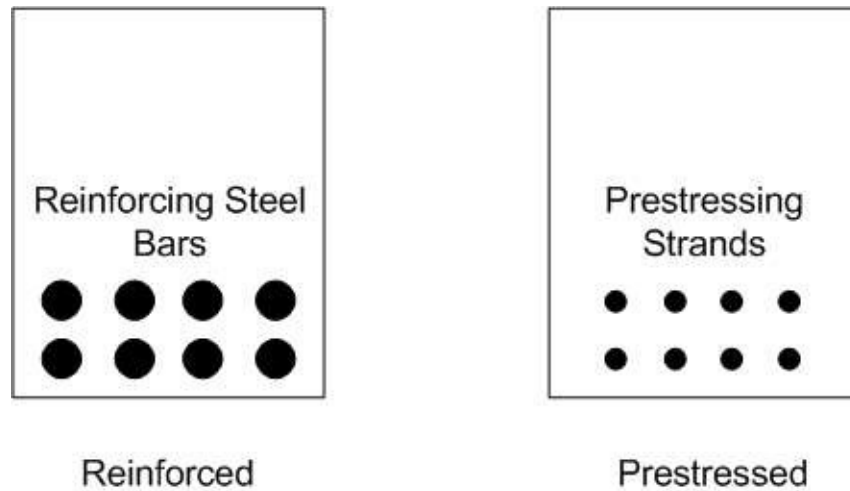
These shapes are used for superstructure members.



**Figure 3.1.8** Prestressed Concrete Shapes

Prestressed concrete beams can be precast at a fabricator's plant using high compressive strength concrete. Increased material strengths, more efficient shapes, the prestress forces and closely controlled fabrication allow these members to carry greater loads. Therefore, they are capable of spanning greater distances and supporting heavier live loads. Bridges using members of this type and material have been widely used in the United States since World War II.

Prestressed concrete is generally more economical than conventionally reinforced concrete because the prestressing force lowers the neutral axis, putting more of the concrete section into compression. Also, the prestress steel is very high strength, so fewer pounds of steel are needed (see Figure 3.1.9).



**Figure 3.1.9** Non-prestressed Mild Steel Reinforced Concrete vs. Precast Prestressed Concrete

I-beams, distinguished by their "I" shape, function as superstructure members and support the deck. This type of beam can be used for spans as long as 150 feet.

Bulb-tee beams are distinguished by their "T" shapes, with a bulb-shaped section (similar to the bottom flange of an I-beam) at the bottom of the vertical leg of the tee. This type of beam can be used for spans as long as 200 feet.

Box beams, distinguished by a square or rectangular shape, usually have a beam depth greater than 17 inches. Box beams can be adjacent or spread, and they are typically used for short and medium span bridges. Adjacent box beams have practical span lengths that range 40 to 130 feet and spread box beams have practical span lengths that range up to 130 feet.

Box girders, distinguished by their trapezoidal or rectangular box shapes, function as both deck and superstructure. Box girders are used for long span or curved bridges and can be precast and erected in segments or cast in place. Spans lengths can range from 130 to 1000 feet.

Voided slabs, distinguished by their rectangular shape and their interior voids, are generally precast units supported by the substructure. The interior voids are used to reduce the dead load. Voided slabs can be used for spans up to 60 feet.

### Axially-Loaded Compression Members

Concrete axially-loaded compression members are used in bridges in the form of:

- Columns
- Arches
- Piles

These members are conventionally reinforced to carry bending forces and to augment their compression load capacity.

Columns are straight members which can carry axial load, horizontal load, and bending and are used as substructure elements. Columns are commonly square, rectangular, or round.

An arch can be thought of as a curved column and is commonly used as a superstructure element. Concrete superstructure arches are generally square or rectangular in cross section.

Piles are slender columns that support the substructure footing or partially form the substructure. Piles may be partially above ground but are usually completely buried (see Figure 3.1.10). Concrete piles may be conventionally reinforced or prestressed.



**Figure 3.1.10** Concrete Pile Bent

## Iron Shapes

Iron was used predominately as a bridge material between 1850 and 1900. Stronger and more fire resistant than wood, iron was widely used to carry the expanding railroad system during this period.

There are two types of iron members: cast iron and wrought iron. Cast iron is formed by casting, whereas wrought iron is formed by forging or rolling the iron into the desired form.

### Cast Iron

Historically, cast iron preceded wrought iron as a bridge material. The method of casting molten iron to form a desired shape was more direct than forging wrought iron.

Casting allowed iron to be formed into almost any shape. However, because of cast iron's brittleness and low tensile strength, bridge members of cast iron were best used to carry axial compression loads. Therefore, cast iron members were usually cylindrical or box-shaped to efficiently resist axial loads.

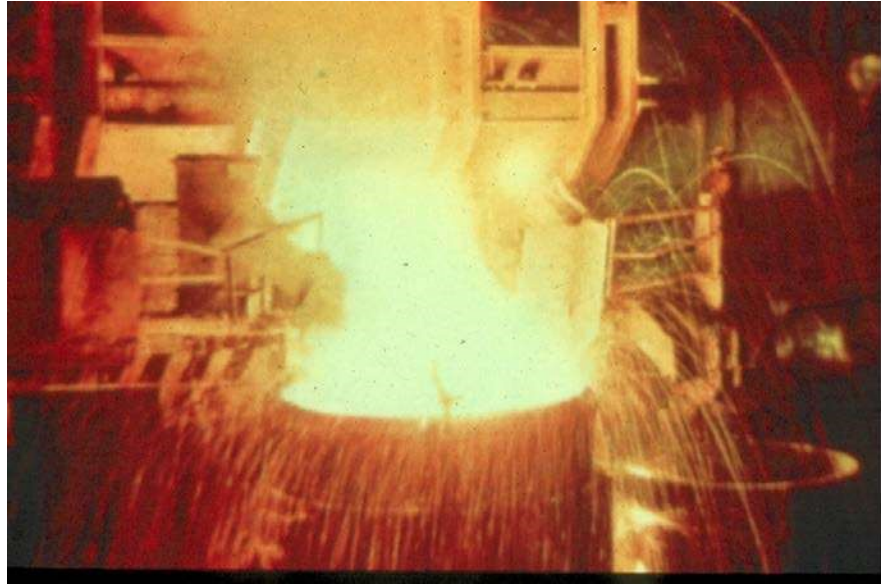
### Wrought Iron

In the late 1800's, wrought iron virtually replaced the use of cast iron. The two primary reasons for this were that wrought iron was better suited to carry tensile loads and advances in rolling technology made wrought iron shapes easier to obtain and more economical to use. Advances in technology made it possible to form a variety of shapes by rolling, including:

- Rods and wire
- Bars
- Plates
- Angles
- Channels
- I-Beams

## Steel Shapes

Steel bridge members began to be used in the United States in the late 1800's and, by 1900, had virtually replaced iron as a bridge material. The replacement of iron by steel was the result of advances in steel making (see Figure 3.1.11). These advances yielded a steel material that surpassed iron in both strength and elasticity. Steel could carry heavier loads and better withstand the shock and vibration of ever-increasing live loads. Since the early 1900's, the quality of steel has continued to improve. Stronger and more ductile A36, A572, A588, and, more recently, HPS steels have replaced early grades of steel, such as A7.



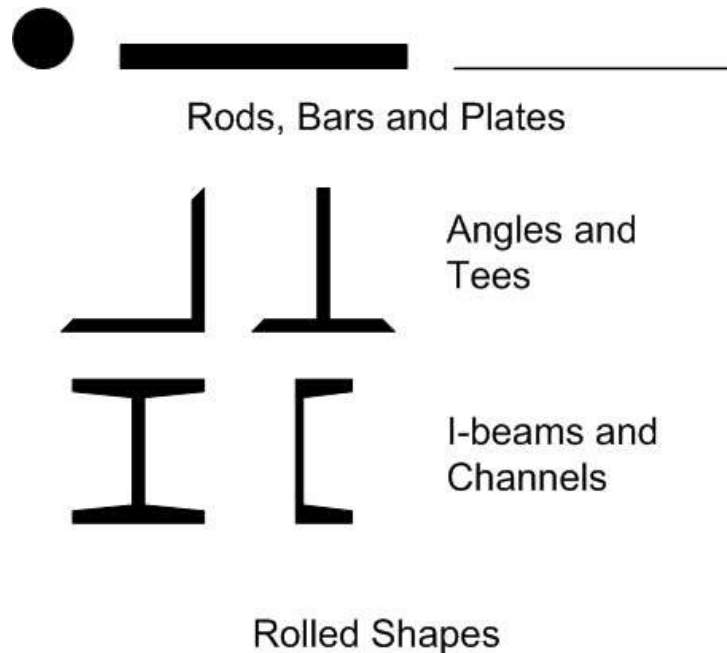
**Figure 3.1.11** Steel Making Operation

Due to their strength, steel bridge members are used to carry axial forces as well as bending forces. Steel shapes are generally either rolled or built-up.

### **Rolled Shapes**

Rolled steel shapes commonly used on bridges include (see Figure 3.1.12):

- Bars and plates
- Angles
- Channels
- S Beams (American standard “I” beams)
- W Beams (Wide flange “I” beams)



**Figure 3.1.12** Common Rolled Steel Shapes

The standard weights and dimensions of these shapes can be found in the American Institute of Steel Construction (AISC) *Manual of Steel Construction*.

Bars and plates are flat pieces of steel. Bars are normally considered to be up to 8 inches in width. Common examples of bars include lacing bars on a truss and steel eyebars. Plates are designated as flat plates if they are over 8 inches in width. A common example of a plate is the gusset plate on a truss. Bars and plates are dimensioned as follows: width x thickness x length. Examples of bar and plate dimensions include:

- Lacing bar: 2" x 3/8" x 1'-3"
- Gusset plate: 21" x 1/2" x 4'-4"

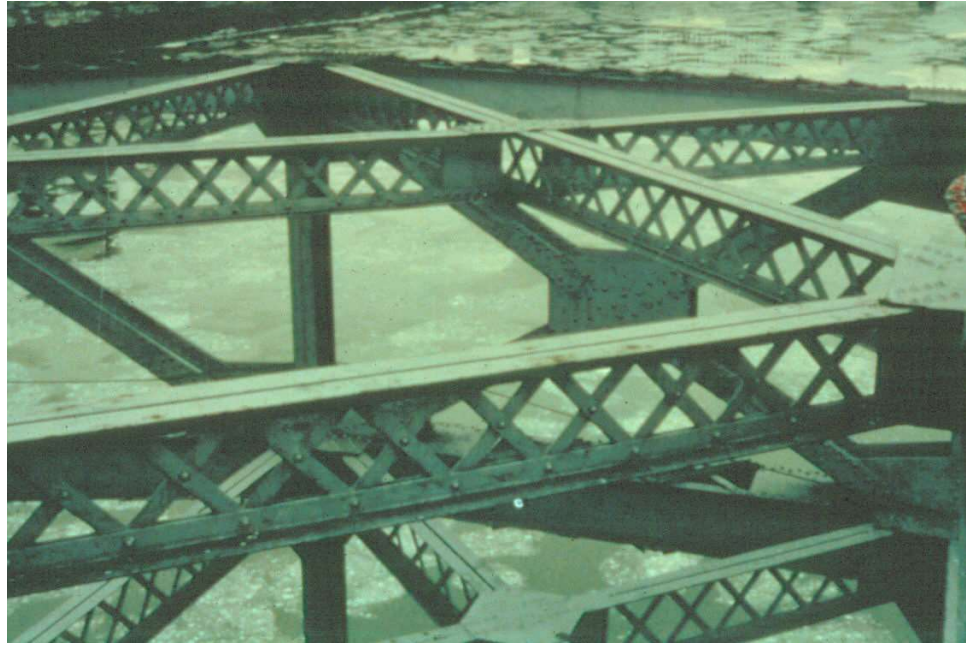
Angles are “L”-shaped members, the sides of which are called “legs”. Each angle has two legs, and the width of the legs can either be equal or unequal. When dimensioning angles, the two leg widths are given first, followed by the thickness and the length. Examples of angle dimensions include:

- L 4" x 4" x 1/4" x 3'-2"
- 2L's 5" x 3" x 3/8" x 1'-1"

Angles range in size from 1"x1"x1/4" to 8"x8"x1-1/8". Angles range in weight from less than 1 pound per foot to almost 60 pounds per foot.

Angles, bars, and plates are commonly connected to form bracing members (see Figure 3.1.13).





**Figure 3.1.13** Bracing Members Made from Angles, Bars, and Plates

Channels are squared-off "C"-shaped members and are used as diaphragms, struts, or other bracing members. The top and bottom parts of a channel are called the flanges. Channels are dimensioned by the depth (the distance between outside edges of the flanges) in inches, the weight in pounds per foot, and the length in inches. Examples of channel dimensions include:

- C 9 x 15 x 9'-6"
- C 12 x 20.7 x 11'-2-1/2"

When measuring a channel, it is not possible for the inspector to know how much the channel section weighs. In order to identify a channel, measurements of the average thickness, flange width, the web depth, and the thickness are needed. From this information, the inspector can then determine the true channel designation through the use of reference books such as American Institute of Steel Construction (AISC) *Manual of Steel Construction*.

Standard channels range in depth from 3 inches to 15 inches, and weights range from less than 5 pounds per foot to 50 pounds per foot. Nonstandard sections (called miscellaneous channels or MC) are rolled to depths of up to 18 inches, weighing up to 60 pounds per foot.

Beams are "I"-shaped sections used as main load-carrying members. The load-carrying capacity generally increases as the member size increases. The early days of the iron and steel industry saw the various manufacturers rolling beams to their own standards. It was not until 1896 that beam weights and dimensions were standardized when the Association of American Steel Manufacturers adopted the American Standard beam. Because of this, I-beams are referred to by many designations, depending on their dimensions and the time period in which the particular shape was rolled. Today all I-beams are dimensioned according to their depth and weight per unit length.

Examples of beam dimensions include:

- S15x50 - an American Standard (hence the “S”) beam with a depth of 15 inches and a weight of 50 pounds per foot
- W18x76 - a wide (W) flange beam with a depth of 18 inches and a weight of 76 pounds per foot

Some of the more common designations for rolled I-beams are:

- S = American Standard beam
- W = Wide flange beam
- WF = Wide flange beam
- CB = Carnegie beam
- M = Miscellaneous beam
- HP = H-pile

To identify an I-beam, measurements of the depth, the flange width and thickness, and the web thickness (if possible) are needed. With this information, the inspector can then determine the beam designation from reference books such as American Institute of Steel Construction (AISC) *Manual of Steel Construction*.

These beams normally range in depth from 3 to 36 inches and range in weight from 6 to over 300 pounds per foot. There are some steel mills that can roll beams up to 44 inches deep.

### **Built-up Shapes**

Built-up shapes offer a great deal of flexibility in designing member shapes. As such, they allow the bridge engineer to customize the members for their particular need. Built-up shapes are fabricated by either riveting, bolting or welding techniques.

The practice of riveting steel shapes began in the 1800’s and continued through the 1950’s. Typical riveted shapes include truss members, girders and boxes.

Riveted girders are large I-beam members fabricated from plates and angles. These girders were used when the largest rolled beams were not large enough as required by design (see Figure 3.1.14).

Riveted boxes are large rectangular shapes fabricated from plates, angles, or channels. These boxes are used for cross-girders, truss chord members, and substructure members (see Figure 3.1.15).

As technology improved, riveting was replaced by high strength bolting and welding. Popular since the early 1960's, welded steel shapes include girders and boxes.

Welded girders are large I-beam members fabricated from plates. They are referred to as welded plate girders and have replaced the riveted girder (see Figure 3.1.16).

Welded boxes are large, rectangular-shaped members fabricated from plates. Welded boxes are commonly used for superstructure girders, truss members, and cross girders. Welded box shapes have replaced riveted box shapes (see Figure 3.1.17).

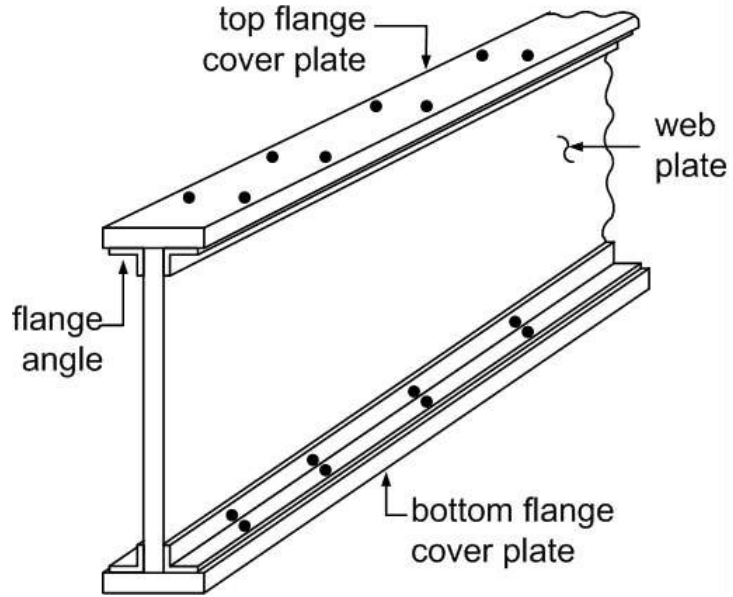
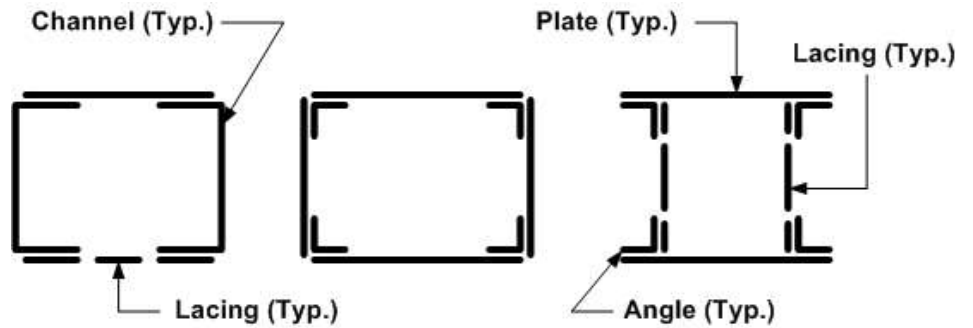
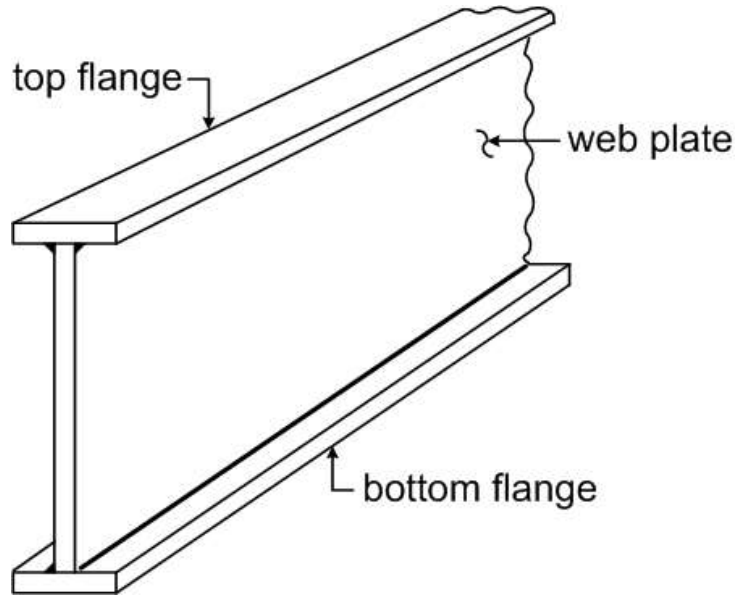


Figure 3.1.14 Riveted Plate Girder

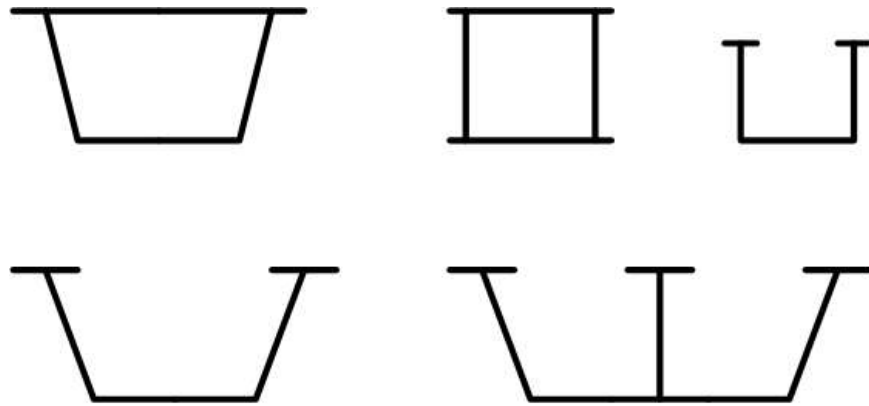


### Riveted Box Shapes

Figure 3.1.15 Riveted Box Shapes



**Figure 3.1.16** Welded I-Beam

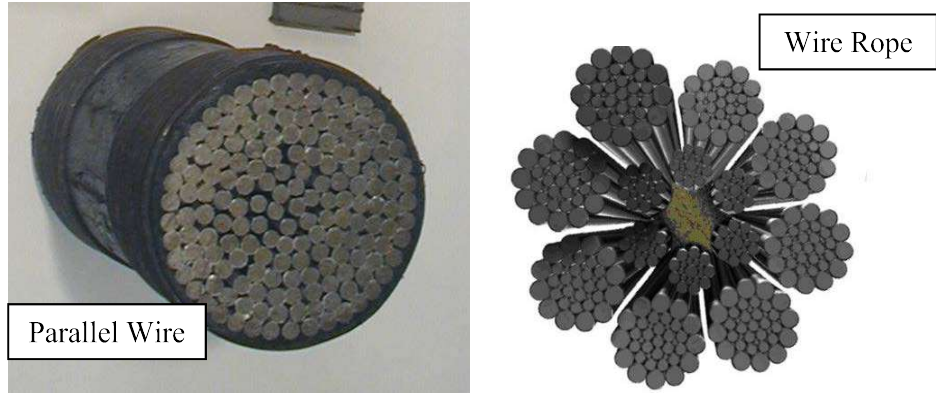


**Welded Box Shapes**

**Figure 3.1.17** Welded Box Shapes

### Cables

Steel cables (see Figure 3.1.18) are tension members and are used in suspension, tied-arch, and cable-stayed bridges. They are used as main cables and hangers of these bridge types (see Figure 3.1.19 and 3.1.20). Refer to Topic 16.1 for a more detailed description of cable-supported bridges.



**Figure 3.1.18** Cable Cross-Sections



**Figure 3.1.19** Cable-Supported Bridge: Suspension Cables and Hangers



**Figure 3.1.20** Cable-Supported Bridge: Cable Stayed

### 3.1.6

#### Connections

Rolled and built-up steel shapes are used to make stringers, floorbeams, girders, trusses, frames, arches and other bridge members. These members require structural joints, or connections, to transfer loads between members. There are several different types of bridge member connections:

- Pin connections
- Riveted connections
- Bolted connections
- Welded connections
- Pin and hanger assemblies
- Splice connections

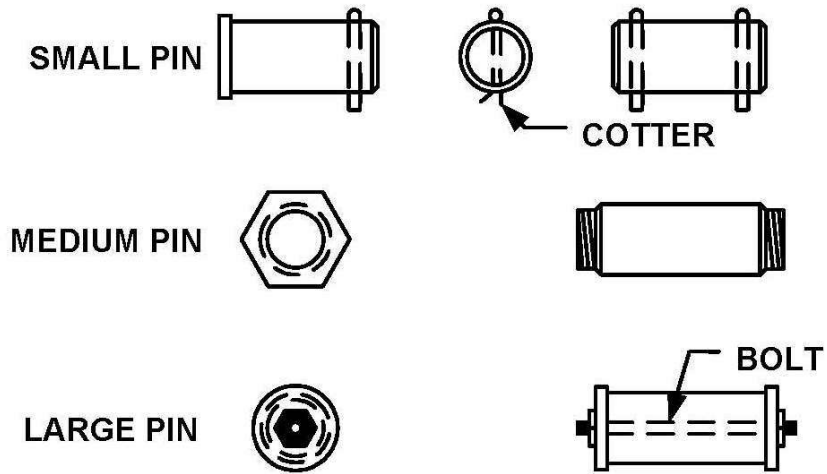
#### Pin Connections

Pins are cylindrical bars produced by forging, casting, or cold-rolling. The pin sizes and configurations are as follows (see Figure 3.1.21):

- A small pin, 1-1/4 to 4 inches in diameter, is usually made with a cotter pin hole at one or both ends
- A medium pin, up to 10 inches in diameter, usually has threaded end projections for recessed retainer nuts
- A large pin, over 10 inches in diameter, is held in place by a recessed cap at each end and is secured by a bolt passing completely through the caps and pin

Pins are often surrounded by a protective sleeve, which may also act as a spacer to separate member elements. Pin connections are commonly used in eyebar trusses, hinged arches, pin and hanger assemblies, and bearing supports (see Figure 3.1.22).





**Figure 3.1.21** Sizes of Bridge Pins



**Figure 3.1.22** Pin-Connected Eyebars

The major advantages of using pin connection details are the design simplicity and to facilitate rotation. The design simplicity afforded by pin connections reduces the amount and complexity of design calculations. By allowing for end rotation, pin connections reduce the level of stress in the member.

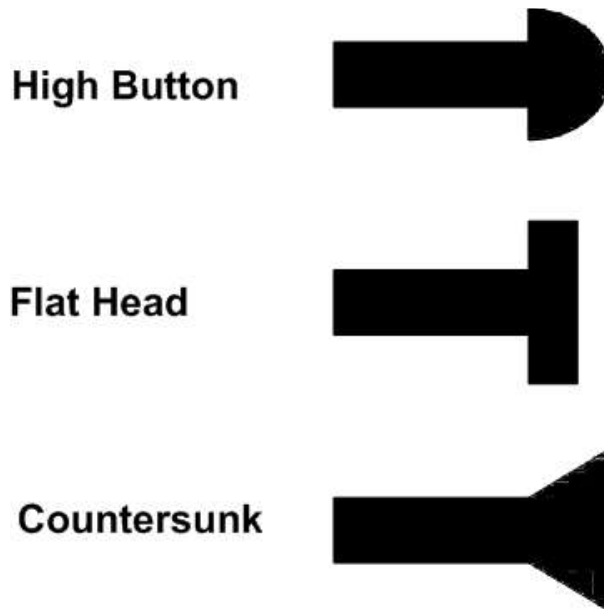
The major disadvantages of pin connection details are the result of vibration, pin wear, unequal eyebar tension, unseen corrosion, and poor inspectability. Vibrations increase with pin connections because they allow more movement than more rigid types of connections. As a result of increased vibration, moving parts are subject to wear.

Pin connections were commonly used in trusses, suspended girder spans and some bearings. These pin connections are susceptible to freezing due to corrosion. This results in changes in structural behavior and undesirable stresses when axially-loaded members must resist bending.

Some pins connect multiple eyebars. Since the eyebars may have different lengths, they may experience different levels of tension. In addition, because parts of the pin surface are hidden from view by the eyebars, links, or connected parts, an alternate method of completely inspecting the pin may be needed (e.g., ultrasonic testing or pin removal).

**Riveted Connections** The rivet was the primary fastener used in the early days of iron and steel bridges. High strength bolts replaced rivets by the early 1960's.

The standard head is called a high-button or acorn-head rivet. Flat-head and countersunk-head rivets were also used in areas of limited clearance, such as a hanger connection (see Figure 3.1.23).



**Figure 3.1.23** Types of Rivet Heads

There are two grades of rivets typically found on bridges:

- ASTM A502 Grade 1 (formerly ASTM A141) low carbon steel
- ASTM A502 Grade 2 (formerly ASTM A195) high strength steel

The rivet sizes most often used on bridges were 3/4, 7/8, or 1-inch shank diameters. Rivet holes were generally 1/16-inch larger than the rivet shank. While the hot rivet was being driven, the shank would increase slightly, filling the hole. As the rivet cooled, it would shrink in length, clamping together the connected elements.

When the inspector can feel vibration on one head of the rivet while hitting the other rivet head with a hammer, this generally indicates that the rivet is loose. This method may not work with sheared rivets clamped between several plates.



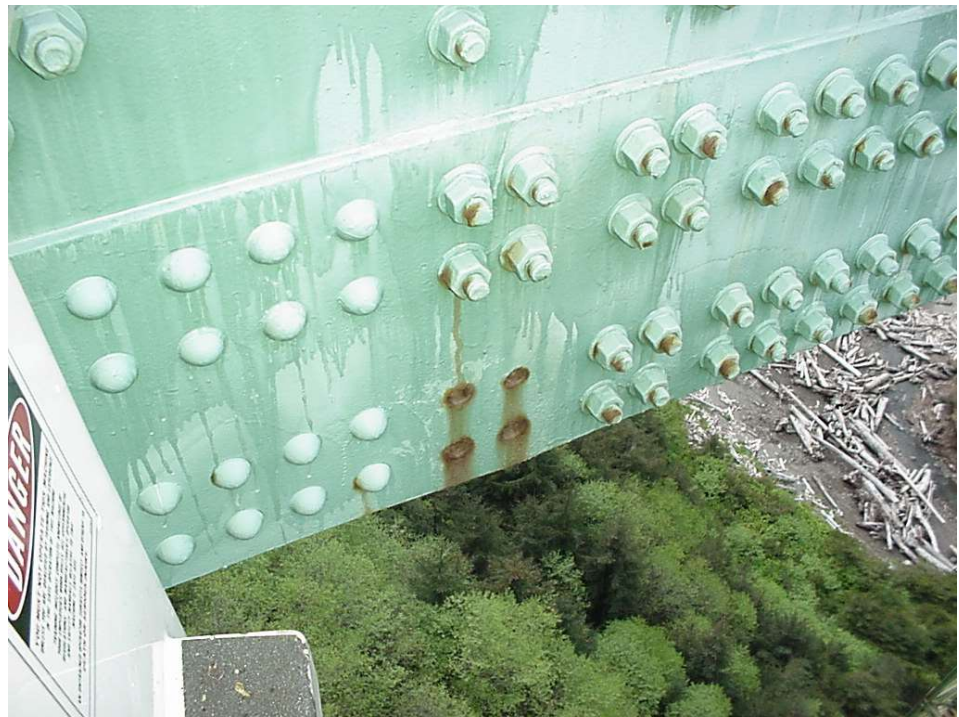
## Bolted Connections

Research into the use of high strength bolts began in 1947. The first specifications for the use of such bolts were published in 1951. The economic and structural advantages of bolts over rivets led to their rapid use by bridge engineers. Bridges constructed in the late 1950's may have a combination of riveted (shop) and bolted (field) connections (see Figure 3.1.24).

Structural bolts consist of three basic material designations:

- ASTM A307 low carbon steel
- ASTM A325 (AASHTO M 164) high strength steel
- ASTM A490 (AASHTO M 253) high strength alloy steel

For further information on the bolts listed above or any other material properties visit the American Society for Testing and Materials International website at: [www.astm.org](http://www.astm.org).



**Figure 3.1.24** Shop Rivets and Field Bolts

The most commonly used bolts on bridges are 3/4, 7/8, and 1-inch in diameter. Larger bolts are often used to anchor the bearings. Bolt holes are typically 1/16-inch larger than the bolt. However, oversized and slotted holes are also permissible if properly detailed.

Tightening high strength bolts puts them in tension, which clamps the member elements together. Although proper installation of new high strength bolts can be verified the use of a torque wrench, this method does not have any merit when inspecting high strength bolts on in-service bridges. The torque is dependent on factors such as bolt diameter, bolt length, connection design (bearing or friction), use of washers, paint and coatings, parallelism of connected parts, dirt, and corrosion. Simple methods, such as visual observation, striking with a hammer and listening or feeling for loose bolts, are the most common methods used by inspectors when inspecting bolts.

## Welded Connections

Pins, rivets, and bolts are examples of mechanical fasteners. A welded connection is not mechanical but rather is a rigid one-piece construction. A properly designed and executed welded joint, in which two pieces are fused together, is as strong as the joined materials.

Similar to mechanical fasteners, welds are used to make structural connections between members and also to connect elements of a built-up member. Welds have also been used in the fabrication and erection of bridges as a way to temporarily hold pieces together prior to field riveting, bolting, or welding. Small temporary erection welds, known as tack welds, can cause serious fatigue problems to certain bridge members (see Figure 3.1.25). Fatigue and fracture of steel bridge members are discussed in detail in Topic 6.4 (refer to 6.4.3 for factors affecting fatigue crack initiation). Welding is also used as a means of sealing joints and seams from moisture.



**Figure 3.1.25** Close-up of Tack Weld on a Riveted Built-up Truss Member

The first specification for using welds on bridges appeared in 1936. Welding eventually replaced rivets for fabricating built-up members. Welded plate girders, hollow box-like truss members, and shear connectors for composite decks are just a few of the advances attributed to welding technology.

Welds need to be carefully inspected for cracks or signs of cracks (e.g., broken paint or rust stains) in both the welds and the adjoining base metal elements.

## Pin and Hanger Assemblies

A pin and hanger assembly is a type of hinge consisting of two pins and two hangers. Pin and hanger assemblies are used in an articulated (continuous bridge with hinges) or a suspended span configuration. The location of the assembly varies depending on the type of bridge. In I-beam bridges, a hanger is located on either side of the webs (see Figure 3.1.26). In suspended span truss bridges, each assembly has a hanger which is similar in shape to the other connecting members (with the exception of the pinned ends). Pin and hangers were used to simply

design before computer programs were developed to aid design of continuous bridges.



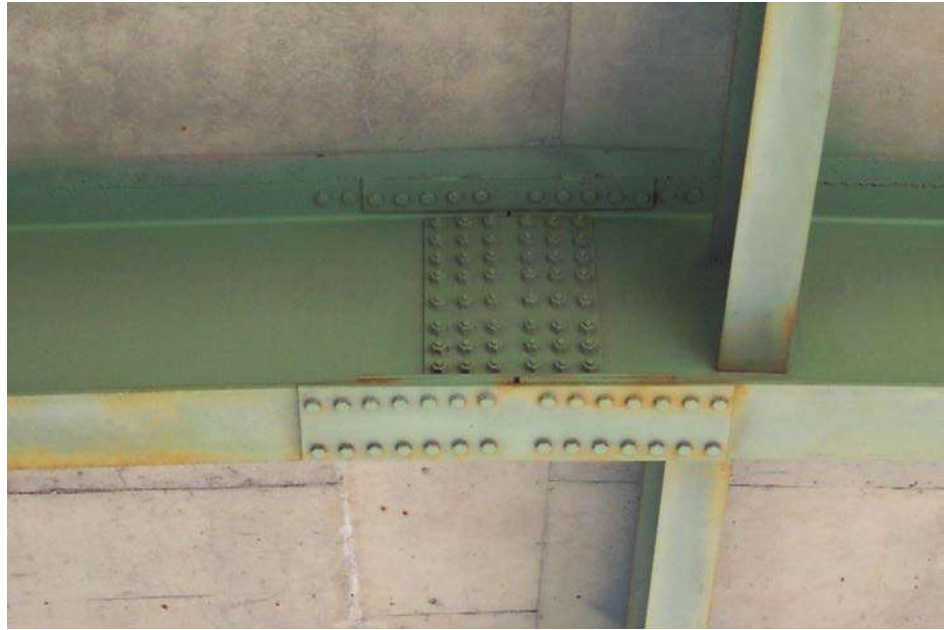
**Figure 3.1.26** Pin and Hanger Assembly

Pin and hanger assemblies must be carefully inspected for signs of wear and corrosion. A potential problem can occur if corrosion of the pin and hanger causes the assembly to "freeze," inhibiting free rotation. This condition does not allow the pin to rotate and results in additional stresses in the pin and hanger and adjacent members. The failure of a pin and hanger assembly may cause a partial or complete failure of the bridge.

### **Splice Connections**

A splice connection is the joining of two sections of the same member, either in the fabrication shop or in the field. This type of connection can be made using rivets, bolts, or welds. Bolted splices are common in multi-beam superstructures due to the limited allowable shipping lengths (see Figure 3.1.27). Shop welded flange splices are common in large welded plate girders and long truss members.





**Figure 3.1.27** Bolted Field Splice

### 3.1.7

#### Decks

The deck is that component of a bridge to which the live load is directly applied. Refer to Chapter 7 for a detailed explanation on the inspection and evaluation of decks.

#### Deck Purpose

The purpose of the deck is to provide a smooth and safe riding surface for the traffic utilizing the bridge (see Figure 3.1.28).



**Figure 3.1.28** Bridge Deck with a Smooth Riding Surface

The function of the deck is to transfer live loads and dead loads of and on the deck to other bridge components commonly referred to as the superstructure (see Figure 3.1.29). However, on some bridges (e.g., a concrete slab bridge), the deck and the superstructure are one unit which distributes the live load directly to the substructure.



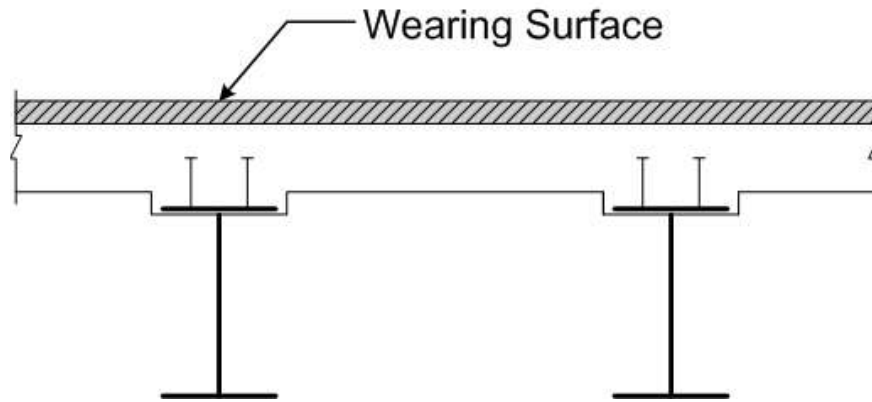
**Figure 3.1.29** Underside View of a Bridge Deck

### Deck Types

Decks function in one of two ways:

- Composite decks - act together with their supporting members and increase superstructure capacity (see Figures 3.1.30 and 3.1.31)
- Non-composite decks - are not integral with their supporting members and do not contribute to structural capacity of the superstructure

An inspector reviews the plans to determine if the deck is composite with the superstructure.



**Figure 3.1.30** Composite Deck and Steel Superstructure



**Figure 3.1.31** Shear Studs on Top Flange of Girder (before Concrete Deck is Placed)

### Deck Materials

There are three common materials used in the construction of bridge decks:

- Timber
- Concrete
- Steel

Fiber Reinforced Polymer (FRP) has been used, but are not as common.



### Timber Decks

Timber decks are often referred to as decking or timber flooring, and the term is limited to the roadway portion which receives vehicular loads. Refer to Topic 7.1 for a detailed explanation on the inspection and evaluation of timber decks.

Five basic types of timber decks are:

- Plank deck (see Figure 3.1.32)
- Nailed laminated deck
- Glued-laminated deck planks
- Stressed-laminated decks
- Structural composite lumber decks



**Figure 3.1.32** Plank Deck

### Concrete Decks

Concrete permits casting in various shapes and sizes and has provided the bridge designer and the bridge builder with a variety of construction methods. Because concrete is weak in tension, it is used together with reinforcement to resist tensile stresses (see Figure 3.1.33). Refer to Topic 7.2 for a detailed explanation on the inspection and evaluation of concrete decks.

There are several common types of concrete decks:

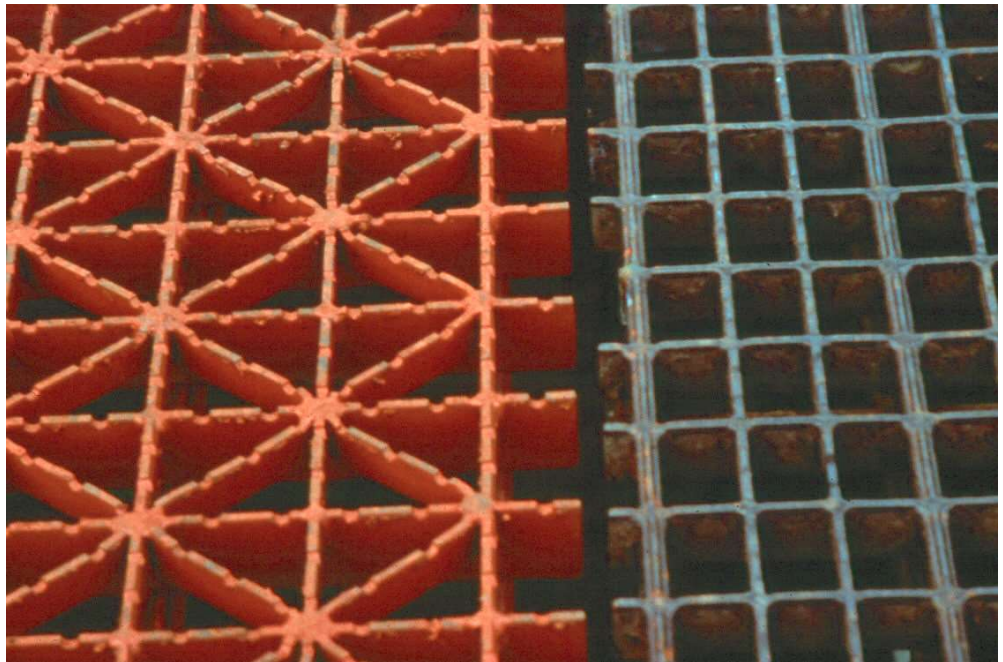
- Conventionally reinforced cast-in-place - removable or stay-in-place forms
- Precast conventionally reinforced
- Precast prestressed
- Precast prestressed deck panels with cast-in-place topping



**Figure 3.1.33** Concrete Deck

### Steel Decks

Steel decks are decks composed of either solid steel plate or steel grids (see Figure 3.1.34). Refer to Topic 7.4 for a detailed explanation on the inspection and evaluation of steel decks.



**Figure 3.1.34** Steel Grid Deck



There are four common types of steel decks:

- Orthotropic deck
- Buckle plate deck (still exist on some older bridges but are no longer used)
- Corrugated steel flooring
- Grid Deck - open, filled, or partially filled

### **Fiber Reinforced Polymer (FRP) Decks**

With the rise of technological development, innovative material such as fiber-reinforced polymer (FRP) bridge decking has begun replacing existing highway bridge decks. Though FRP material is more expensive than conventional bridge materials such as concrete, it has several advantages. These include lighter weight for efficient transport, better resistance to earthquakes, and easier installation. FRP bridge decking is also less affected by water and de-icing salts, which corrode steel and deteriorate concrete (see Figure 3.1.35). Refer to Topic 7.3 for a detailed explanation on the inspection and evaluation of FRP decks.



**Figure 3.1.35** Fiber Reinforced Polymer (FRP) Deck

### Wearing Surfaces

Constant exposure to the elements makes weathering a significant cause of deck deficiency. In addition, vehicular traffic produces damaging effects on the deck surface. For these reasons, a wearing surface is often applied to the surface of the deck. The wearing surface is the topmost layer of material applied to the deck to provide a smooth riding surface and to protect the deck from the effects of traffic and weathering.

A timber deck may have one of the following wearing surfaces:

- Timber planks – running boards
- Bituminous
- Concrete
- Gravel
- Polymers

Concrete decks may have wearing surfaces of:

- Concrete – latex modified concrete (LMC), low slump dense concrete (LSDC), lightweight concrete (LWC), fiber reinforced concrete (FRC), micro-silica modified concrete
- Bituminous (see Figure 3.1.36)
- Polymers - epoxy, polyester, methyl methacrylates



**Figure 3.1.36** Asphalt Wearing Surface on a Concrete Deck

Steel decks may have wearing or riding surfaces of:

- Serrated steel
- Concrete
- Asphalt
- Polymers

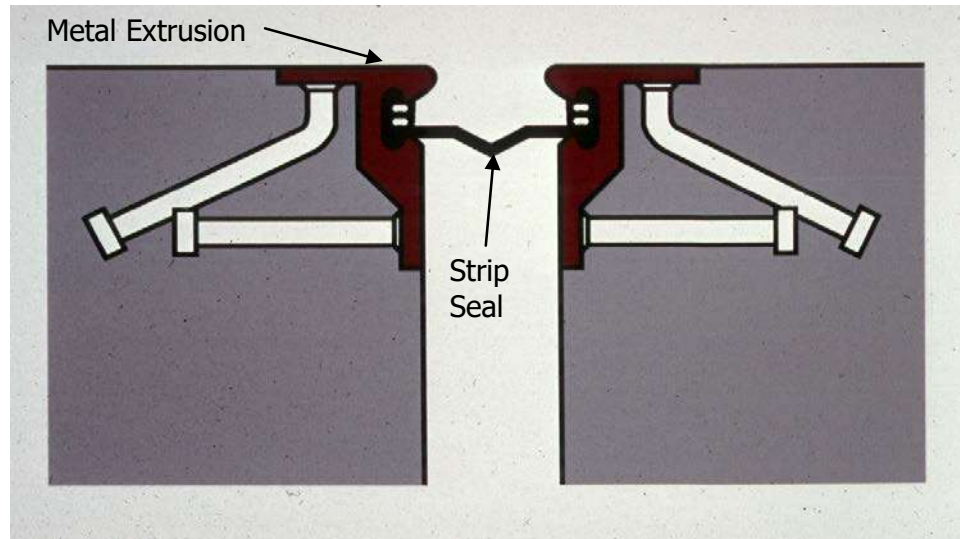
### Deck Appurtenances, Signing and Lighting

### Deck Joints

The primary function of a deck joint is to accommodate the expansion, contraction, and rotation of the superstructure. The joint must also provide a smooth transition from an approach roadway to a bridge deck, or between adjoining segments of bridge deck. Refer to Topic 7.5 for detailed explanation on the inspection and evaluation of deck joints.

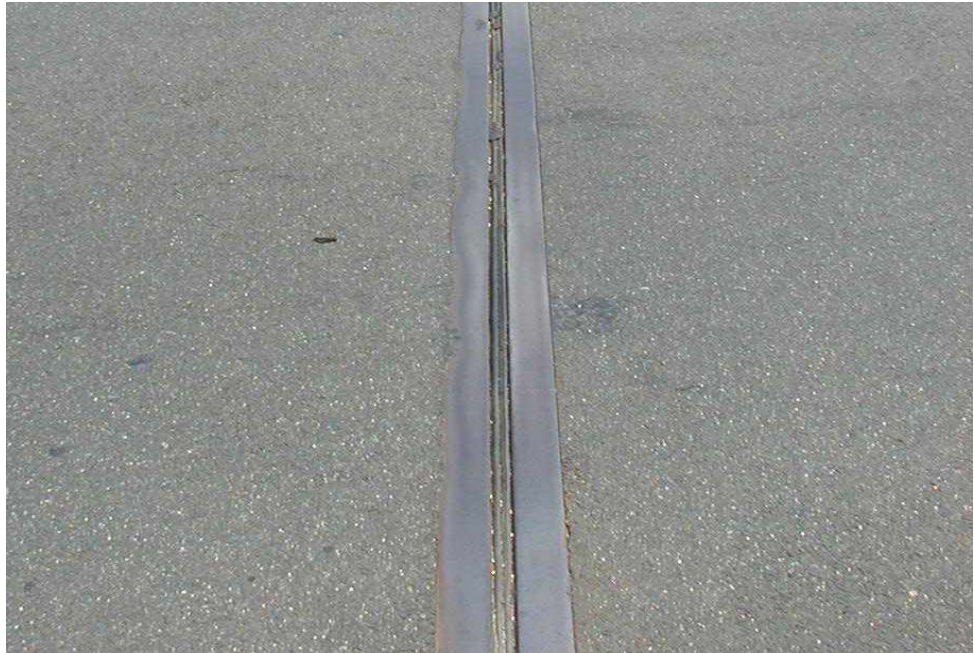
There are six categories of deck joints:

- Strip seal expansion joints (see Figure 3.1.37)
- Pourable joint seals
- Compression joint seals (see Figure 3.1.38)
- Assembly joints with seal (Modular)
- Open expansion joints
- Assembly joints without seals (finger plate and sliding plate joints) (see Figure 3.1.39)

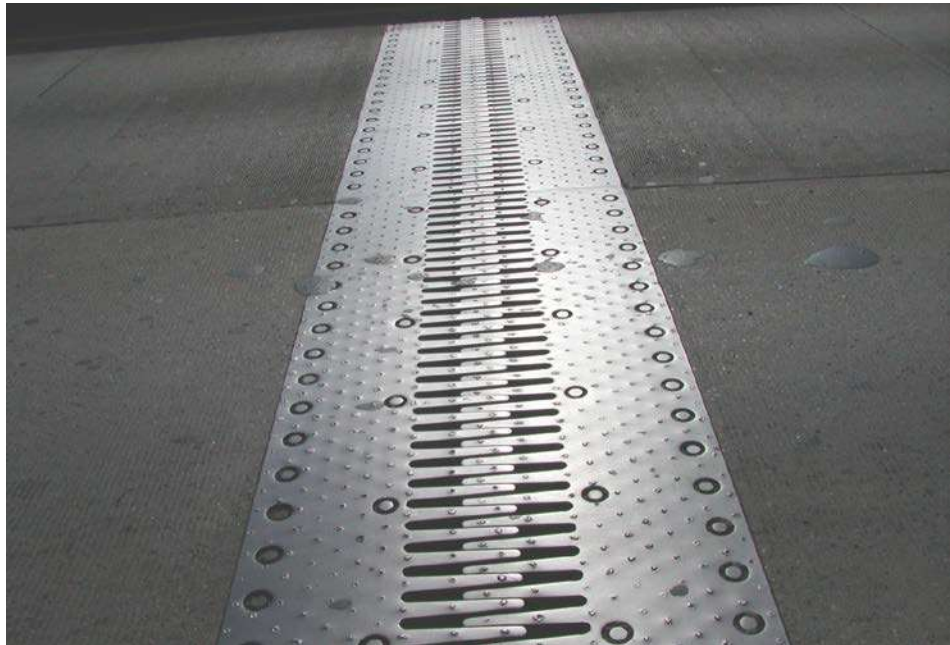


**Figure 3.1.37** Strip Seal Expansion Joint





**Figure 3.1.38** Top View of an Armored Compression Seal in Place



**Figure 3.1.39** Top View of a Finger Plate Joint

## **Drainage Systems**

The primary function of a drainage system is to remove water from the bridge deck, from under unsealed deck joints and from behind abutments and wingwalls. Refer to Topic 7.5 for detailed explanation on the inspection and evaluation of drainage systems.

A deck drainage system has the following components:

- Grade and cross slope
- Inlets
- Outlet pipes
- Downspout pipes - to transport runoff to storm sewers
- Cleanout plugs - for maintenance
- Drainage troughs
- Support brackets/hardware

A joint drainage system is typically a separate gutter or trough used to collect water passing through a finger plate or sliding plate joint.

Combining all these drainage components forms a complete deck drainage system.

Substructure drainage allows the fill material behind an abutment or wingwall to drain any accumulated water.

Substructure drainage is accomplished with weep holes or substructure drain pipes.

## **Traffic Safety Features**

The proper and effective use of traffic barriers minimizes hazards for traffic on the bridge, on the highways, and waterways beneath the bridge.

Bridge barriers can be broken down into two categories:

- Bridge railing - to guide, contain, and redirect errant vehicles
- Pedestrian railing - to protect pedestrians

Examples of railing include:

- Timber plank rail
- Steel angles and bars
- Concrete pigeon hole parapet
- Combination bridge-pedestrian aluminum or steel railing
- New Jersey barrier - a very common concrete barrier (see Figure 3.1.40)

Refer to Topic 7.6 for detailed explanation on the inspection and evaluation of traffic safety features.



**Figure 3.1.40** New Jersey Barrier

### **Sidewalks and Curbs**

The function of sidewalks and curbs is to provide access to and maintain safety for pedestrians and to direct water to the drainage system. Curbs serve to lessen the chance of vehicles crossing onto the sidewalk and endangering pedestrians.

### **Signing**

Signing serves to inform the motorist about bridge or roadway conditions that may be hazardous. Refer to Topic 7.5 for detailed explanation on the inspection and evaluation of signing.

Several signs likely to be encountered are:

- Weight limit and/or lane restrictions (see Figure 3.1.41)
- Speed traffic marker
- Vertical clearance
- Lateral clearance
- Narrow underpass
- Informational and directional
- Object markers





**Figure 3.1.41** Weight Limit Sign and Object Marker Signs

### Lighting

Types of lighting that may be encountered on a bridge include the following (see Figure 3.1.42):

- Highway lighting
- Traffic control lights
- Aerial obstruction lights
- Navigation lights
- Signing lights
- Illumination and drawbridge operation flashing lights

Refer to Topic 7.5 for detailed explanation on the inspection and evaluation of lighting systems.



**Figure 3.1.42** Bridge Lighting

### 3.1.8 Superstructure

#### Superstructure Purpose

The basic purpose of the superstructure is to carry loads from the deck across the span and to the bridge supports commonly referred to as the substructure. The superstructure is that component of the bridge which supports the deck or riding surface of the bridge, as well as the loads applied to the deck.

The function of the superstructure is to span a feature and to transmit loads from the deck to the bridge supports commonly referred to as the substructure. Bridges are categorized by their superstructure type. Superstructures may be characterized with regard to their function (i.e., how they transmit loads to the substructure). Loads may be transmitted through tension, compression, bending, or a combination of these three.

#### Superstructure Types

There are many different superstructure types such as:

- Slabs
- Single web beams/girders
- Box beams/girders (multi-web)
- Trusses
- Arches
- Rigid frames
- Cable-supported bridges
- Movable bridges
- Floating bridges

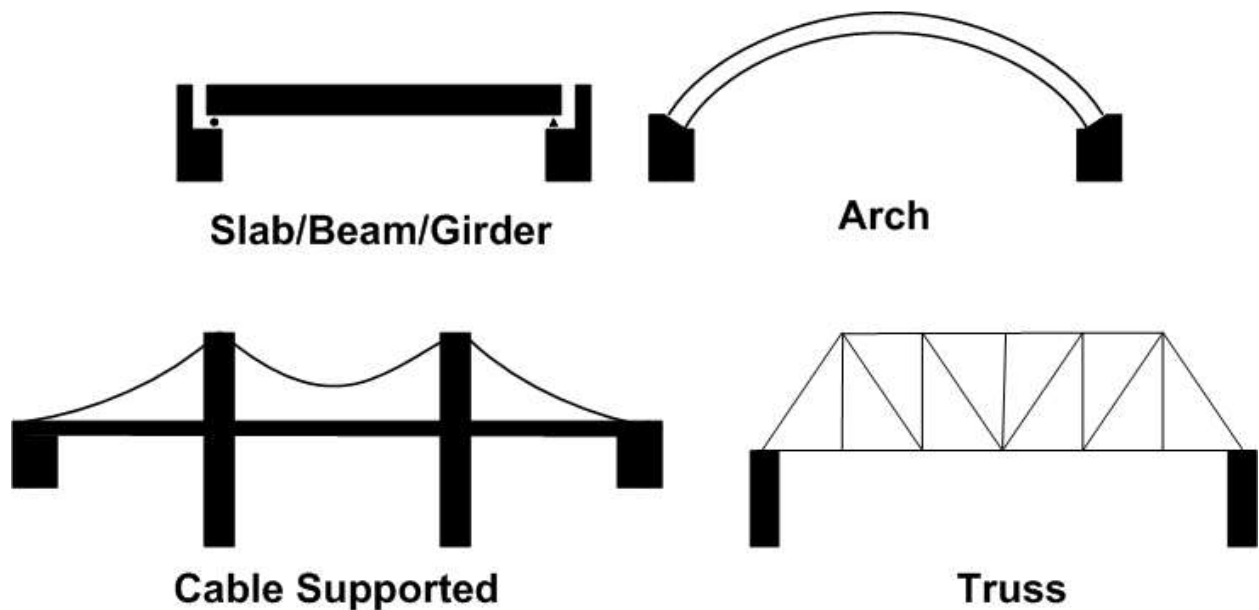


Figure 3.1.43 Four Basic Bridge Types



### Slab Bridges

In slab bridges, loads from the slab are transmitted vertically to the substructure (see Figure 3.1.44).



**Figure 3.1.44** Slab Bridge

### Single Web Beam/Girder Bridges

In the case of beam and girder bridges, loads from the superstructure are transmitted vertically to the substructure. Examples of beam bridges include:

- Beams (timber, concrete, or steel) (see Figures 3.1.45, 3.1.49, 3.1.50)
- Girders (concrete or steel) (see Figures 3.1.46, 3.1.47, 3.1.48, 3.1.51)



**Figure 3.1.45** Beam Bridge



**Figure 3.1.46** Multi-Girder Bridge



**Figure 3.1.47** Girder Floorbeam Stringer Bridge



**Figure 3.1.48** Curved Girder Bridge



**Figure 3.1.49** Tee Beam Bridge





**Figure 3.1.50** Adjacent Box Beam Bridge



**Figure 3.1.51** Box Girder Bridge

### Trusses

Truss members including chords, verticals, and diagonals primarily carry axial tension and compression loads. Trusses can be constructed from timber or steel (see Figures 3.1.52 and 3.1.53).



**Figure 3.1.52** Deck Truss Bridge



**Figure 3.1.53** Through Truss Bridge

### Arches

In the case of arch bridges, the loads from the superstructure are transmitted diagonally to the substructure. True arches are in pure compression. Arch bridges can be constructed from timber, concrete, or steel (see Figures 3.1.54 and 3.1.55).



**Figure 3.1.54** Deck Arch Bridge



**Figure 3.1.55** Through Arch Bridge



### **Rigid Frames**

Rigid frame superstructures are characterized by rigid (moment) connections between the horizontal girder and the legs. This connection allows the transfer of both axial forces and moments into vertical or sloping elements, which may be classified as superstructure or substructure elements depending on the exact configuration. Similar to beam/girder or slab configurations, rigid frame systems may be multiple parallel frames or may contain transverse floorbeams and longitudinal stringers to support the deck. (see Figure 3.1.56)



**Figure 3.1.56** Rigid Frame

### **Cable-Supported Bridges**

In the case of cable-supported bridges, the superstructure loads are resisted by cables which act in tension. The cable forces are then resisted by the substructure anchorages and towers. Cable-supported bridges can be either suspension or cable-stayed (see Figures 3.1.57 and 3.1.58). Refer to Topic 16.1 for a more detailed explanation on cable-supported bridges.



**Figure 3.1.57** Suspension Bridge



**Figure 3.1.58** Cable-stayed Bridge

### **Movable Bridges**

Movable bridges are constructed across designated "Navigable Waters of the United States," in accordance with "Permit Drawings" approved by the U.S. Coast Guard or other agencies. The purpose of a movable bridge is to provide the appropriate channel width and underclearance for passing water vessels when fully opened. Refer to Topic 16.2 for a more detailed explanation on movable bridges.



Movable bridges can be classified into three general groups:

- Bascule (see Figure 3.1.59)
- Swing (see Figure 3.1.60)
- Lift (see Figure 3.1.61)



**Figure 3.1.59** Bascule Bridge



**Figure 3.1.60** Swing Bridge



**Figure 3.1.61** Lift Bridge

### Floating Bridges

Although uncommon, some states have bridges that are not supported by a substructure (see Figure 3.1.62). Instead, they are supported by water. The elevation of the bridge will change as the water level fluctuates.



**Figure 3.1.62** Floating Bridge

**Superstructure Materials**

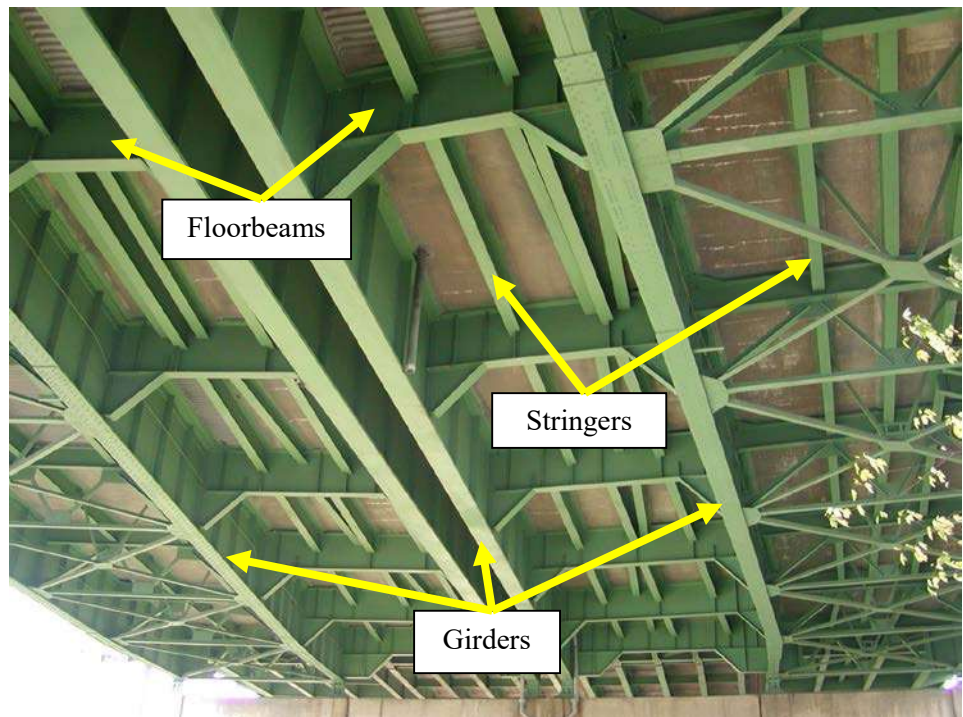
There are three common materials used in the construction of bridge superstructures:

- Timber
- Concrete
- Steel

**Primary Members**

Typical primary members carry primary live load from trucks and typically consist of the following:

- Girders (see Figure 3.1.63)
- Floorbeams (see Figure 3.1.63)
- Stringers (see Figure 3.1.63)
- Trusses
- Spandrel girders (see Figure (3.1.64)
- Spandrel columns (see Figure (3.1.64) or bents
- Arch ribs
- Rib chord bracing
- Hangers
- Frame girder
- Frame leg
- Frame knee
- Pin and hanger links



**Figure 3.1.63** Floor System and Main Supporting Members



Additionally, diaphragms for curved girders may also be considered primary members. Vehicular live load is transmitted between the mains supporting members through the diaphragms in a curved multi-girder arrangement.



**Figure 3.1.64** Main Supporting Members of Deck Arch

### Secondary Members

Secondary members do not normally carry traffic loads directly. Typical secondary elements are:

- Diaphragms (see Figure 3.1.65)
- Cross or X-bracing (see Figure 3.1.66)
- Lateral bracing (see Figure 3.1.67)
- Sway-portal bracing (see Figure 3.1.67)
- Pin and hanger assemblies - Through bolts, pin caps, nuts, cotter pins on small assemblies, spacer washers, doubler plates



**Figure 3.1.65** Diaphragms



**Figure 3.1.66** Cross or X-Bracing



**Figure 3.1.67** Top Lateral Bracing and Sway Bracing

### 3.1.9

---

## Bearings

### Bearing Purpose

A bridge bearing is an element which provides an interface between the superstructure and the bridge supports referred to as the substructure.

There are three primary functions of a bridge bearing:

- Transmit all loads from the superstructure to the substructure
- Permit longitudinal movement of the superstructure due to thermal expansion and contraction
- Allow rotation caused by dead and live load deflection

Bearings that do not allow for horizontal movement of the superstructure are referred to as fixed bearings. Bearings that allow for horizontal movement of the superstructure are known as expansion bearings. Both fixed and expansion bearings permit rotation. Refer to Topic 11.1 for more detailed explanation on expansion/fixed bearings.

### Bearing Types

There are six bearing types that are utilized to accommodate superstructure movement and rotation:

- Elastomeric bearings
- Moveable bearings (roller, sliding, etc.)
- Enclosed/concealed bearings
- Fixed bearings
- Pot bearings
- Disk bearing

Refer to Topic 11.1 for detailed explanations on bridge bearing types.

### Bearing Materials

There are two common materials used in the construction of bridge bearings:

- Steel
- Neoprene

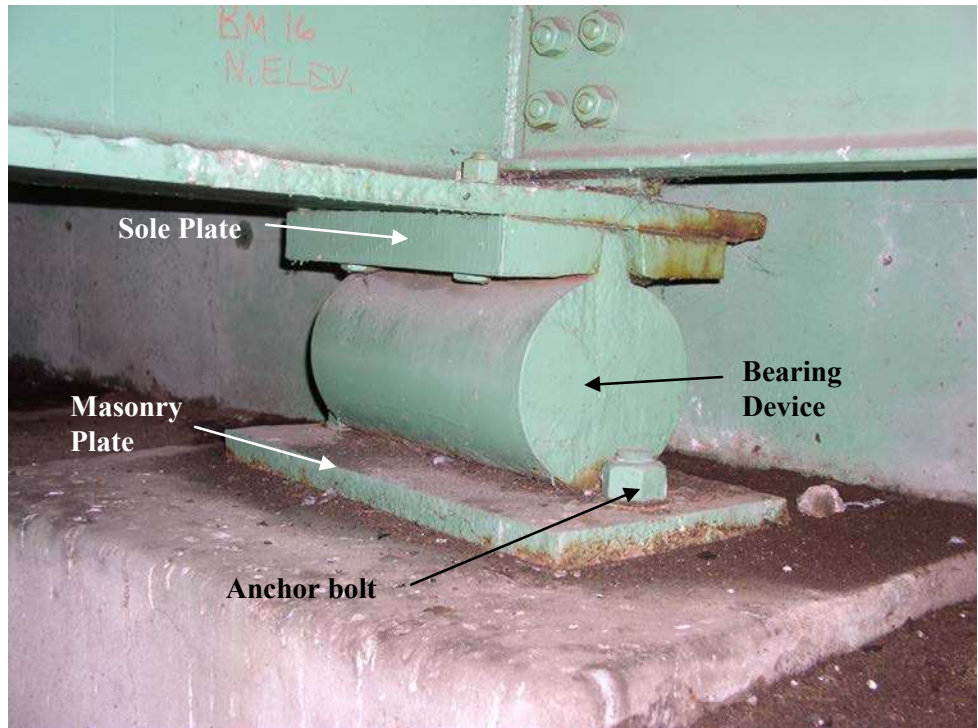
### Bearing Elements

A bridge bearing can be normally categorized into four basic elements (see Figure 3.1.68):

- Sole plate
- Bearing device
- Masonry plate
- Anchor bolts

Refer to Topic 11.1 for detailed explanations of these four bearing elements.





**Figure 3.1.68** Steel Roller Bearing Showing Four Basic Elements

### 3.1.10

#### **Substructure**

The substructure is the component of a bridge which includes all the elements which support the superstructure.

#### **Substructure Purposes**

The purpose of the substructure is to transfer the loads from the superstructure to the foundation soil or rock. Typically the substructure includes all elements below the bearings. The loads are then distributed to the earth.

Substructure units function as both axially-loaded and bending members. These units resist both vertical and horizontal loads applied from the superstructure and roadway embankment. Substructures are divided into two basic categories:

- Abutments
- Piers and bents

Abutments provide support for the ends of the superstructure and retain the roadway approach embankment (see Figure 3.1.69). Piers and bents provide support for the superstructure at intermediate points along the bridge spans (see Figure 3.1.70).





**Figure 3.1.69** Abutment



**Figure 3.1.70** Pier

## Substructure Types

### Abutments

Basic types of abutments include:

- Cantilever or full height abutment - extends from the grade line of the roadway or waterway below, to that of the road overhead (see Figure 3.1.71).
- Stub, semi-stub, or shelf abutment - located within the topmost portion of the end of an embankment or slope. In the case of a stub, less of the

abutment stem is visible than in the case of the full height abutment. Most new construction uses this type of abutment. These abutments may be supported on deep foundations (see Figure 3.1.72).

- Spill-through or open abutment - consists of columns and has no solid wall, but rather is open to the embankment material. The approach embankment material is usually rock (see Figure 3.1.73).
- Integral abutment – superstructure and substructure are integral and act as one unit without an expansion joint or bearings. Relative movement of the abutment with respect to the backfill allows the structure to adjust to thermal expansions and contractions. Pavement relief joints at the ends of approach slabs are provided to accommodate the thermal movement between bridge deck and the approach roadway pavement (see Figure 3.1.74)



**Figure 3.1.71** Cantilever Abutment (or Full Height Abutment)



**Figure 3.1.72** Stub Abutment



**Figure 3.1.73** Spill-Through or Open Abutment





**Figure 3.1.74** Integral Abutment

Refer to Topic 12.1 for a more detailed explanation on bridge abutments.

### **Piers and Bents**

A pier has only one footing at each substructure unit (the footing may serve as a pile cap). A bent has several footings or no footing, as is the case with a pile bent. Refer to Topic 12.2 for a more detailed explanation on bridge piers and bents.

There are four basic types of piers:

- Solid shaft pier (see Figures 3.1.75 and 3.1.76)
- Column pier (see Figure 3.1.77)
- Column pier with web wall (see Figure 3.1.78)
- Cantilever or hammerhead pier (see Figure 3.1.79)



**Figure 3.1.75** Solid Shaft Pier



**Figure 3.1.76** Solid Shaft Pier





**Figure 3.1.77** Column Pier



**Figure 3.1.78** Column Pier with Web Wall and Cantilevered Pier Caps



**Figure 3.1.79** Cantilever or Hammerhead Pier

There are two basic types of bents:

- Column bent (see Figure 3.1.80)
- Pile bent (see Figure 3.1.81)



**Figure 3.1.80** Column Bent



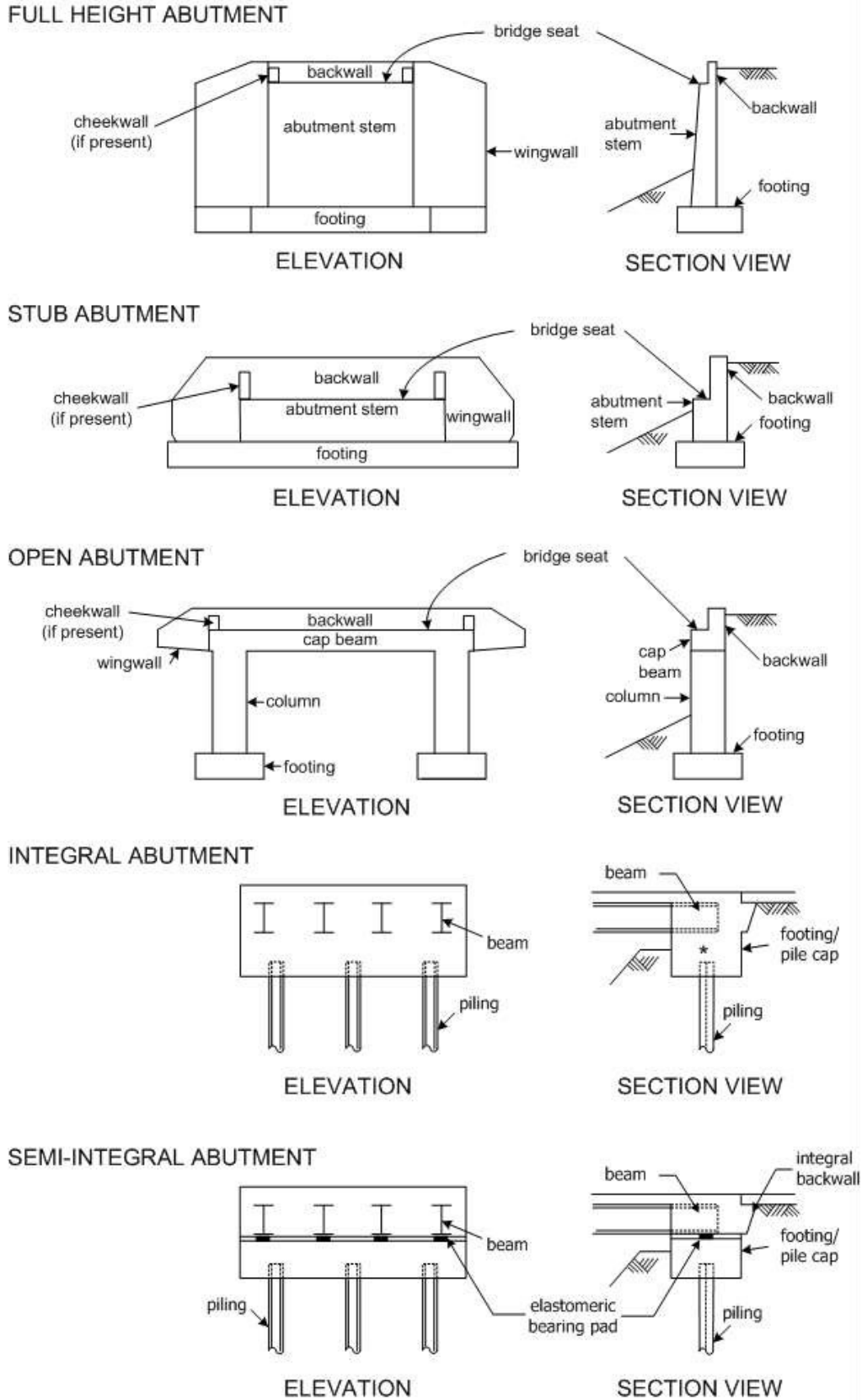
**Figure 3.1.81** Pile Bent

**Substructure Materials** There are four common materials used in the construction of bridge substructures:

- Timber
- Concrete
- Steel
- Masonry

**Substructure Elements** A bridge substructure can consist of several different elements (see Figure 3.1.82). Typical elements can include:

- Abutments
  - Backwall
  - Stem/bridge seat
  - Footing
  - Integral backwall



\* Some states weld beam and piles prior to concrete placement

Figure 3.1.82 Schematic of Common Abutment Types

- Pier/Bents
  - Pier caps
  - Columns/Piles
  - Walls
  - Footing

Refer to Topics 12.1 and 12.2 for a detailed explanation of abutment, pier and bent elements.

### 3.1.11

#### **Culverts**

Culverts are often viewed as small bridges, being constructed entirely below and independent of the roadway surface. However, culverts do not have a deck, superstructure, or substructure. Culverts that are 20 feet or greater are defined as a bridge, according to the NBIS definition for bridge length (see Topic 3.1.3).

#### **Culvert Purpose**

A culvert is primarily a hydraulic structure, and its main purpose is to transport water flow efficiently.

#### **Culvert Materials**

There are several common materials used in the construction of culverts:

- Concrete
- Masonry
- Steel
- Aluminum
- Timber
- Plastic

#### **Culvert Types**

Refer to Topic 14.1 for a detailed explanation about culvert characteristics.

##### **Rigid Culverts**

Rigid culverts can carry the load the same way a frame or an arch does by resisting the loads in bending and shear or frame an arch action (see Figure 3.1.83). Refer to Topic 14.2 for a detailed explanation of rigid culverts.





**Figure 3.1.83** Rigid Culvert

### **Flexible Culverts**

Flexible culverts will require lateral earth pressure to help maintain their shape. The loads are distributed through the flexible culvert and backfill. The backfill is critical to a flexible culverts performance (see Figure 3.1.84). Refer to Topic 14.3 for a detailed explanation of flexible culverts.



**Figure 3.1.84** Flexible Culvert

# Table of Contents

## Chapter 4 Bridge Inspection Reporting

---

|       |   |        |
|-------|---|--------|
| 4.1   | Structure Inventory .....   | 4.1.1  |
| 4.1.1 | Introduction.....   | 4.1.1  |
| 4.1.2 | FHWA Structure Inventory, Appraisal and Condition Ratings         | 4.1.1  |
|       | Substitutes for the SI&A Sheet.....                               | 4.1.1  |
|       | Data Entry Requirements .....                                     | 4.1.2  |
| 4.1.3 | Inventory Items .....   | 4.1.14 |
| 4.1.4 | Condition and Appraisal Rating Items.....                         | 4.1.15 |
|       | Condition Rating Items.....                                       | 4.1.15 |
|       | Appraisal Rating Items .....                                      | 4.1.15 |
| 4.1.5 | The Role of Inventory Items in Bridge<br>Management Systems ..... | 4.1.16 |

This page intentionally left blank

# Chapter 4

## Bridge Inspection Reporting

### Topic 4.1 Structure Inventory

#### 4.1.1

##### Introduction

A good bridge inspection reporting system is essential to document bridge conditions and to protect the public's safety and investment in bridge structures. It is, therefore, essential that bridge inspection data be clear, accurate, and complete, since it is an integral part of the lifelong record file of the bridge.

Because of the requirements that are fulfilled in accordance with the National Bridge Inspection Standards (NBIS), it is necessary to employ a uniform bridge inspection reporting system. A uniform reporting system is essential to evaluate the condition of a structure correctly and efficiently. It is a valuable aid in establishing maintenance priorities and replacement priorities, and in determining structure capacity and the cost of maintaining the nation's bridges. Consequently, importance of the reporting system cannot be overemphasized. Success of any bridge inspection program is dependent upon its reporting system.

#### 4.1.2

##### FHWA Structure Inventory, Appraisal and Condition Ratings

The FHWA *Recording and Coding Guide for the Structure Inventory and Appraisal of the Nation's Bridges (FHWA Coding Guide)* is used for defining the bridge inventory and the items to be used to collect information on the overall condition of the deck, superstructure, substructure, and channel. The data is reported to FHWA in accordance with the *FHWA Coding Guide*. It is not an inspection guide. Each state may use its own coding scheme, provided that the data is directly translatable into the format of the *FHWA Coding Guide*. In other words, the states are responsible for having the capability to obtain, store, and report certain information about bridges, for collection by FHWA as requested.

The Structure Inventory and Appraisal (SI&A) sheet is a tabulation of information that is submitted for each individual structure (see Figure 4.1.1).

For the small structures and culverts that are less than or equal to 20 feet, some states still collect the inventory information and generate a "local" database.

It is important to note that the SI&A sheet is not an inspection form. Rather, it is a summary sheet of bridge data required by the FHWA to effectively monitor and manage the National Bridge Inspection Program and the Highway Bridge Program.

##### Substitutes for the SI&A Sheet

There are suitable substitutes for the SI&A sheet. Some states simply reprint the federal form with the same items and item numbers. A few states have elaborate Bridge Management Systems (BMS) with different item numbers that collect all



the data listed on the SI&A form plus additional items not reported to the FHWA (see Figures 4.1.1 through 4.1.5).

**Data Entry Requirements** For routine, in-depth, fracture critical member, underwater, damage and special inspections, the NBIS requires entry of the SI&A data into the State or Federal agency inventory within 90 days of the date of inspection for State or Federal agency bridges and within 180 days of the date of inspection for all other bridges.

For existing bridge modifications that alter previously recorded data and for new bridges, the NBIS requires entry of the SI&A data into the State or Federal agency inventory within 90 days after the completion of the work for State or Federal agency bridges and within 180 days after the completion of the work for all other bridges.

For changes in load restriction or closure status, the NBIS requires entry of the SI&A data into the State or Federal agency inventory within 90 days after the change in status of the structure for State or Federal agency bridges and within 180 days after the change in status of the structure for all other bridges.



Appendix A

OMB No. 2125-0501

Structure Inventory and Appraisal Sheet

NATIONAL BRIDGE INVENTORY - - - - - STRUCTURE INVENTORY AND APPRAISAL 10/15/94

\*\*\*\*\* IDENTIFICATION \*\*\*\*\*

(1) STATE NAME - \_\_\_\_\_ CODE \_\_\_\_\_  
 (8) STRUCTURE NUMBER \_\_\_\_\_ # \_\_\_\_\_  
 (5) INVENTORY ROUTE (ON/UNDER) - \_\_\_\_\_ = \_\_\_\_\_  
 (2) HIGHWAY AGENCY DISTRICT \_\_\_\_\_  
 (3) COUNTY CODE \_\_\_\_\_ (4) PLACE CODE \_\_\_\_\_  
 (6) FEATURES INTERSECTED - \_\_\_\_\_  
 (7) FACILITY CARRIED - \_\_\_\_\_  
 (9) LOCATION - \_\_\_\_\_  
 (11) MILEPOINT/KILOMETERPOINT \_\_\_\_\_  
 (12) BASE HIGHWAY NETWORK - \_\_\_\_\_ CODE \_\_\_\_\_  
 (13) LRS INVENTORY ROUTE & SUBROUTE # \_\_\_\_\_  
 (16) LATITUDE \_\_\_\_\_ DEG \_\_\_\_\_ MIN \_\_\_\_\_ SEC  
 (17) LONGITUDE \_\_\_\_\_ DEG \_\_\_\_\_ MIN \_\_\_\_\_ SEC  
 (98) BORDER BRIDGE STATE CODE \_\_\_\_\_ % SHARE \_\_\_\_\_ %  
 (99) BORDER BRIDGE STRUCTURE NO. # \_\_\_\_\_

\*\*\*\*\* STRUCTURE TYPE AND MATERIAL \*\*\*\*\*

(43) STRUCTURE TYPE MAIN: MATERIAL - \_\_\_\_\_  
 TYPE - \_\_\_\_\_ CODE \_\_\_\_\_  
 (44) STRUCTURE TYPE APPR: MATERIAL - \_\_\_\_\_  
 TYPE - \_\_\_\_\_ CODE \_\_\_\_\_  
 (45) NUMBER OF SPANS IN MAIN UNIT \_\_\_\_\_  
 (46) NUMBER OF APPROACH SPANS \_\_\_\_\_  
 (107) DECK STRUCTURE TYPE - \_\_\_\_\_ CODE \_\_\_\_\_  
 (108) WEARING SURFACE / PROTECTIVE SYSTEM:  
 A) TYPE OF WEARING SURFACE - \_\_\_\_\_ CODE \_\_\_\_\_  
 B) TYPE OF MEMBRANE - \_\_\_\_\_ CODE \_\_\_\_\_  
 C) TYPE OF DECK PROTECTION - \_\_\_\_\_ CODE \_\_\_\_\_

\*\*\*\*\* AGE AND SERVICE \*\*\*\*\*

(27) YEAR BUILT \_\_\_\_\_  
 (106) YEAR RECONSTRUCTED \_\_\_\_\_  
 (42) TYPE OF SERVICE: ON - \_\_\_\_\_  
 UNDER - \_\_\_\_\_ CODE \_\_\_\_\_  
 (28) LANES: ON STRUCTURE \_\_\_\_\_ UNDER STRUCTURE \_\_\_\_\_  
 (29) AVERAGE DAILY TRAFFIC \_\_\_\_\_  
 (30) YEAR OF ADT \_\_\_\_\_ (109) TRUCK ADT \_\_\_\_\_ %  
 (19) BYPASS, DETOUR LENGTH \_\_\_\_\_ KM

\*\*\*\*\* GEOMETRIC DATA \*\*\*\*\*

(48) LENGTH OF MAXIMUM SPAN \_\_\_\_\_ M  
 (49) STRUCTURE LENGTH \_\_\_\_\_ M  
 (50) CURB OR SIDEWALK: LEFT \_\_\_\_\_ M RIGHT \_\_\_\_\_ M  
 (51) BRIDGE ROADWAY WIDTH CURB TO CURB \_\_\_\_\_ M  
 (52) DECK WIDTH OUT TO OUT \_\_\_\_\_ M  
 (32) APPROACH ROADWAY WIDTH (W/SHOULDERS) \_\_\_\_\_ M  
 (33) BRIDGE MEDIAN - \_\_\_\_\_ CODE \_\_\_\_\_  
 (34) SKEW \_\_\_\_\_ DEG (35) STRUCTURE FLARED \_\_\_\_\_  
 (10) INVENTORY ROUTE MIN VERT CLEAR \_\_\_\_\_ M  
 (47) INVENTORY ROUTE TOTAL HORIZ CLEAR \_\_\_\_\_ M  
 (53) MIN VERT CLEAR OVER BRIDGE RDWY \_\_\_\_\_ M  
 (54) MIN VERT UNDERCLEAR REF - \_\_\_\_\_ M  
 (55) MIN LAT UNDERCLEAR RT REF - \_\_\_\_\_ M  
 (56) MIN LAT UNDERCLEAR LT REF - \_\_\_\_\_ M

\*\*\*\*\* NAVIGATION DATA \*\*\*\*\*

(38) NAVIGATION CONTROL - \_\_\_\_\_ CODE \_\_\_\_\_  
 (111) PIER PROTECTION - \_\_\_\_\_ CODE \_\_\_\_\_  
 (39) NAVIGATION VERTICAL CLEARANCE \_\_\_\_\_ M  
 (116) VERT-LIFT BRIDGE NAV MIN VERT CLEAR \_\_\_\_\_ M  
 (40) NAVIGATION HORIZONTAL CLEARANCE \_\_\_\_\_ M

\*\*\*\*\* CLASSIFICATION \*\*\*\*\*

(112) NBIS BRIDGE LENGTH - \_\_\_\_\_  
 (104) HIGHWAY SYSTEM - \_\_\_\_\_  
 (26) FUNCTIONAL CLASS - \_\_\_\_\_  
 (100) DEFENSE HIGHWAY - \_\_\_\_\_  
 (101) PARALLEL STRUCTURE - \_\_\_\_\_  
 (102) DIRECTION OF TRAFFIC - \_\_\_\_\_  
 (103) TEMPORARY STRUCTURE - \_\_\_\_\_  
 (105) FEDERAL LANDS HIGHWAYS - \_\_\_\_\_  
 (110) DESIGNATED NATIONAL NETWORK - \_\_\_\_\_  
 (20) TOLL - \_\_\_\_\_  
 (21) MAINTAIN - \_\_\_\_\_  
 (22) OWNER - \_\_\_\_\_  
 (37) HISTORICAL SIGNIFICANCE - \_\_\_\_\_

\*\*\*\*\* CONDITION \*\*\*\*\*

(58) DECK \_\_\_\_\_  
 (59) SUPERSTRUCTURE \_\_\_\_\_  
 (60) SUBSTRUCTURE \_\_\_\_\_  
 (61) CHANNEL & CHANNEL PROTECTION \_\_\_\_\_  
 (62) CULVERTS \_\_\_\_\_

\*\*\*\*\* LOAD RATING AND POSTING \*\*\*\*\*

(31) DESIGN LOAD - \_\_\_\_\_ OR \_\_\_\_\_  
 (63) OPERATING RATING METHOD - \_\_\_\_\_  
 (64) OPERATING RATING - \_\_\_\_\_  
 (65) INVENTORY RATING METHOD - \_\_\_\_\_  
 (66) INVENTORY RATING - \_\_\_\_\_  
 (70) BRIDGE POSTING - \_\_\_\_\_  
 (41) STRUCTURE OPEN, POSTED OR CLOSED - \_\_\_\_\_  
 DESCRIPTION - \_\_\_\_\_

\*\*\*\*\* APPRAISAL \*\*\*\*\*

(67) STRUCTURAL EVALUATION \_\_\_\_\_  
 (68) DECK GEOMETRY \_\_\_\_\_  
 (69) UNDERCLEARANCES, VERTICAL & HORIZONTAL \_\_\_\_\_  
 (71) WATERWAY ADEQUACY \_\_\_\_\_  
 (72) APPROACH ROADWAY ALIGNMENT \_\_\_\_\_  
 (36) TRAFFIC SAFETY FEATURES \_\_\_\_\_  
 (113) SCOUR CRITICAL BRIDGES \_\_\_\_\_

\*\*\*\*\* PROPOSED IMPROVEMENTS \*\*\*\*\*

(75) TYPE OF WORK - \_\_\_\_\_ CODE \_\_\_\_\_  
 (76) LENGTH OF STRUCTURE IMPROVEMENT \_\_\_\_\_ M  
 (94) BRIDGE IMPROVEMENT COST \$ \_\_\_\_\_,000  
 (95) ROADWAY IMPROVEMENT COST \$ \_\_\_\_\_,000  
 (96) TOTAL PROJECT COST \$ \_\_\_\_\_,000  
 (97) YEAR OF IMPROVEMENT COST ESTIMATE \_\_\_\_\_  
 (114) FUTURE ADT \_\_\_\_\_  
 (115) YEAR OF FUTURE ADT \_\_\_\_\_

\*\*\*\*\* INSPECTIONS \*\*\*\*\*

(90) INSPECTION DATE \_\_\_\_/\_\_\_\_/\_\_\_\_ (91) FREQUENCY \_\_\_\_ MO  
 (92) CRITICAL FEATURE INSPECTION: (93) CFI DATE  
 A) FRACTURE CRIT DETAIL - \_\_\_\_ - \_\_\_\_ MO A) \_\_\_\_/\_\_\_\_  
 B) UNDERWATER INSP - \_\_\_\_ - \_\_\_\_ MO B) \_\_\_\_/\_\_\_\_  
 C) OTHER SPECIAL INSP - \_\_\_\_ - \_\_\_\_ MO C) \_\_\_\_/\_\_\_\_

Figure 4.1.2 Typical SI&A Sheet with NBI Data Only

## Oregon Department of Transportation

### Bridge Inspection Report

|                      |                                |                     |                                    |                    |                       |
|----------------------|--------------------------------|---------------------|------------------------------------|--------------------|-----------------------|
| <b>District</b>      | 07                             | <b>Structure</b>    | Coos Bay,<br>Hwy 9<br>(McCullough) | <b>Bridge ID</b>   | 01823                 |
| <b>Fac Crossed</b>   | COOS BAY<br>(MCCULLOUGH<br>BR) | <b>Owner</b>        | State Highway<br>Agency            | <b>Fac Carried</b> | US101(HWY009)         |
| <b>Suff Rating</b>   | 46.5                           | <b>County</b>       | Coos                               | <b>Mile Point</b>  | 233.99mi              |
| <b>AC Depth</b>      | 0.00                           | <b>Record Type</b>  | 1                                  | <b>Insp Date</b>   | 06/11/2009            |
| <b>Bridge Length</b> | 5305.00ft                      | <b>Insp Freq</b>    | 24                                 | <b>Inspector 1</b> | Jeff Swanstrom (2010) |
|                      |                                | <b>Bridge Width</b> | 33.80ft                            | <b>Inspector 2</b> | JOHN MILCAREK (241 )  |

Signature: \_\_\_\_\_

|      |   | Element Condition States |           |           |      |      |      |    |    |        |
|------|---|--------------------------|-----------|-----------|------|------|------|----|----|--------|
| Elem | Description                                     | Env                      | Qty       | Units     | 1    | 2    | 3    | 4  | 5  | status |
| 18   | Concrete Deck - Protected w/ Thin Overlay       | Sev.                     | 152100.00 | sqft (SF) | 0%   | 100% | 0%   | 0% | 0% |        |
| 110  | Reinforced Conc Open Girder/Beam                | Sev.                     | 3332.00   | ft (LF)   | 70%  | 20%  | 10%  | 0% | 0% |        |
| 113  | Painted Steel Stringer                          | Sev.                     | 15372.00  | ft (LF)   | 47%  | 48%  | 5%   | 0% | 0% |        |
| 121  | Painted Steel Bottom Chord Thru Truss           | Sev.                     | 3416.00   | ft (LF)   | 47%  | 48%  | 5%   | 0% | 0% |        |
| 126  | Painted Steel Thru Truss (excl. bottom chord)   | Sev.                     | 3416.00   | ft (LF)   | 45%  | 50%  | 5%   | 0% | 0% |        |
| 144  | Reinforced Conc Arch                            | Sev.                     | 5522.00   | ft (LF)   | 78%  | 20%  | 2%   | 0% | 0% |        |
| 152  | Painted Steel Floor Beam                        | Sev.                     | 2090.00   | ft (LF)   | 50%  | 48%  | 2%   | 0% | 0% |        |
| 155  | Reinforced Conc Floor Beam                      | Sev.                     | 4862.00   | ft (LF)   | 80%  | 15%  | 5%   | 0% | 0% |        |
| 205  | Reinforced Conc Column or Pile Extension        | Sev.                     | 64        | (EA)      | 75%  | 20%  | 5%   | 0% | 0% |        |
| 210  | Reinforced Conc Pier Wall                       | Sev.                     | 11        | (EA)      | 20%  | 75%  | 5%   | 0% | 0% |        |
| 215  | Reinforced Conc Abutment                        | Sev.                     | 2         | (EA)      | 50%  | 50%  | 0%   | 0% | 0% |        |
| 220  | Reinforced Conc Submerged Pile Cap/Footing      | Sev.                     | 9         | (EA)      | 100% | 0%   | 0%   | 0% | 0% |        |
| 221  | Submerged Concrete Spread Footing               | Sev.                     | 2         | (EA)      | 100% | 0%   | 0%   | 0% | 0% |        |
| 223  | Submerged, Conc Footing Seal                    | Sev.                     | 2         | (EA)      | 100% | 0%   | 0%   | 0% | 0% |        |
| 234  | Reinforced Conc Cap                             | Sev.                     | 12        | (EA)      | 80%  | 15%  | 5%   | 0% | 0% |        |
| 304  | Open Expansion Joint                            | Sev.                     | 70.00     | ft (LF)   | 50%  | 50%  | 0%   | 0% | 0% |        |
| 305  | Polychlorophrene Joint                          | Sev.                     | 2552.00   | ft (LF)   | 10%  | 20%  | 70%  | 0% | 0% |        |
| 309  | Other Joint                                     | Sev.                     | 3700.00   | ft (LF)   | 100% | 0%   | 0%   | 0% | 0% |        |
| 310  | Elastomeric Bearing                             | Sev.                     | 8         | (EA)      | 100% | 0%   | 0%   | 0% | 0% |        |
| 311  | Moveable Bearing (roller, sliding, etc.)        | Sev.                     | 290       | (EA)      | 35%  | 60%  | 5%   | 0% | 0% |        |
| 313  | Fixed Bearing                                   | Sev.                     | 4         | (EA)      | 50%  | 50%  | 0%   | 0% | 0% |        |
| 321  | Reinforced Conc Approach Slab w/ or w/o AC Ovly | Sev.                     | 2         | (EA)      | 50%  | 50%  | 0%   | 0% | 0% |        |
| 325  | Traffic Impact Condition                        | Ben.                     | 1         | (EA)      | 0%   | 100% | 0%   | 0% | 0% |        |
| 326  | Deck Wearing Surface                            | Ben.                     | 1         | (EA)      | 0%   | 100% | 0%   | 0% | 0% |        |
| 331  | Reinforced Conc Bridge Railing                  | Sev.                     | 7044.00   | ft (LF)   | 90%  | 10%  | 0%   | 0% | 0% |        |
| 334  | Metal Bridge Railing - Coated                   | Sev.                     | 1708.00   | ft (LF)   | 70%  | 30%  | 0%   | 0% | 0% |        |
| 357  | Pack Rust                                       | Sev.                     | 1         | (EA)      | 0%   | 0%   | 100% | 0% | 0% |        |
| 359  | Soffit of Concrete Deck or Slab                 | Sev.                     | 1         | (EA)      | 38%  | 30%  | 30%  | 2% | 0% |        |
| 363  | Section Loss                                    | Sev.                     | 1         | (EA)      | 100% | 0%   | 0%   | 0% | 0% |        |

**Figure 4.1.3** Oregon Bridge Inspection Report with Element Level Data



|     |                                 |      |             |      |      |      |    |    |    |
|-----|---------------------------------|------|-------------|------|------|------|----|----|----|
| 390 | Paint, Alkyd (incl red lead)    | Sev. | 3713.50sqft | (SF) | 35%  | 60%  | 5% | 0% | 0% |
| 990 | Miscellaneous Items             | Sev. | 1           | (EA) | 100% | 0%   | 0% | 0% | 0% |
| 994 | Miscellaneous Fender Sys Timber | Sev. | 2           | (EA) | 0%   | 100% | 0% | 0% | 0% |

| Appraisal          |       |                         | NBI Category            |       |                |
|--------------------|-------|-------------------------|-------------------------|-------|----------------|
| Appraisal          | NBI # | Rating                  | Category                | NBI # | Rating         |
| Scour              | 113   | 5 Stable w/in footing   | Deck Condition          | 58    | 6 Satisfactory |
| Bridge Rail        | 36A   | 0 Substandard           | Superstructure          | 59    | 5 Fair         |
| Transitions        | 36B   | 0 Substandard           | Substructure            | 60    | 6 Satisfactory |
| Approach Rail      | 36C   | 0 Substandard           | Channel                 | 61    | 7 Minor Damage |
| Rail Ends          | 36D   | 0 Substandard           | Culvert/Retaining Walls | 62    | N N/A (NBI)    |
| Structural         | 67    | 5 Above Min Tolerable   |                         |       |                |
| Deck               | 68    | 3 Intolerable - Correct |                         |       |                |
| Clearance          | 69    | N Not applicable (NBI)  |                         |       |                |
| Waterway           | 71    | 9 Above Desirable       |                         |       |                |
| Approach Alignment | 72    | 8 Equal Desirable Crit  |                         |       |                |

**Remarks**

**P Conc Deck/Thin Ovl (18)**  
 (6/09) Thin overlay overtops one of the joints.

**R/Conc Open Girder (110)**  
 Bt 5 girder 1 has exposed stirrups (6/09)

**P/Stl Thru Truss/Bot (121)**  
 (6/09) Lots of garbage/materials (PVC) on steel joints below the deck.

**P/Stl Thru Truss/Top (126)**  
 (6/09) Missing rivets in SE spire at start of thru truss.

**R/Conc Arch (144)**  
 CONCRETE ARCH'S HAVE HORIZONTAL CRACKS - NEAR THE CENTER TOP... (6/09) Steel exposed in spandrel column as well as cracks with efflor. on arches. Cathodic Protection project underway @ South approach spans

**R/Conc Floor Beam (155)**  
 SOME OF THE CAPS, COLUMNS, HAVE CRACKS, SPALLS & EXPOSED REBAR

**R/Conc Pier Wall (210)**  
 (6/09) Bt 7 pier wall, S. side, has corrosion cracking @ bottom of columns and delamination.

**R/Conc Cap (234)**  
 MOST OF THE CAPS NEED WASHED... (6/09) Bent 7 cap has spalling w/exposed stirrup near column 2.

**Open Expansion Joint (304)**  
 MANY OF THE JOINTS EDGES ARE SPALLING. ....ALL JOINTS ARE LEAKING .....JOINT AT MIDSPAN HAS FAILED - PERCALL CORNER FAILED -

**Other Joint (309)**  
 [ none ]

**Moveable Bearing (311)**  
 (6/09) Verify total quantity of bearings after completion of cathodic protection.

**Conc Bridge Railing (331)**  
 Concrete rail being replaced in south approach spans (6/09)

**Misc (990)**  
 (6/09) Earthquake retrofit on S. end, bent 3, cables are tight

**Fender System (994)**  
 UW report states rating for elem. 994 as CS1-95%, CS2-3%, and CS3-2%

**Notes**

**Inspection Notes**

Reviewed for Item #113, stays a T, jr, user #152, 09-02-08. Tidal hydraulics study needed to determine seriousness and extent of possible scour during the flood of maximum scour potential. Tidal hydraulics study done by West Consultants, changed item 113 from T to 5, 01-11-11, jr.

**Figure 4.1.3** Oregon Bridge Inspection Report with Element Level Data (cont.)

BRIDGE GROUP

**Structure Inventory & Appraisal**

|                        |  |                     |  |                             |  |
|------------------------|--|---------------------|--|-----------------------------|--|
| Structure Number: 4023 |  | Structure Name: RCB |  | Feature Under: WASH         |  |
| Route: 60 MP 56.85     |  | Road Name: US 60    |  | Agency: ADOT                |  |
|                        |  |                     |  | Location: 7.3 M E JCT SR 72 |  |

| LOCATION INFORMATION         |                  | DIMENSIONS                      |      | PROPOSED IMPROVEMENTS           |     |
|------------------------------|------------------|---------------------------------|------|---------------------------------|-----|
| N1-State Code:               | 049              | N32-Appr Rdwy Width (feet):     | 36   | N75-Type of Work:               |     |
| N2-State Hwy District:       | 88               | N48-Max Span Length (feet):     | 10   | N76-Length of Str Imp (feet):   | 0   |
| N3-County Code:              | 029              | N49-Structure Length (feet):    | 32   | N94-Br Improv Cost (x1000):     | \$0 |
| N4-Place Code:               | 00000            | N50a-Lt Curb/Swtk Width (feet): | 1    | N95-Rdwy Improv Cost (x1000):   | \$0 |
| N16-Latitude:                | 33 deg 47.1 min  | N50b-Rt Curb/Swtk Width (feet): | 1    | N96-Total Project Cost (x1000): | \$0 |
| N17-Longitude:               | 113 deg 36.5 min | N51-Br Width Curb-Curb (feet):  | 39   | N97-Year of Cost Estimate:      |     |
| N98-Border St Code - % Resp: | - 0              | N52-Deck Width Out-Out (feet):  | 41.6 |                                 |     |
| N99-Border Bridge Number:    |                  | N112-NBIS Br Length?            | Y    |                                 |     |

| INVENTORY ROUTE DATA              |                   | VERTICAL and HORIZONTAL CLEARANCE |        | CONSTRUCTION PROJECT DATA    |            |
|-----------------------------------|-------------------|-----------------------------------|--------|------------------------------|------------|
| N19-Detour Length (miles):        | 20                | N53-Min Vert Over Clr (feet):     | 99.99  | N27-Year Built:              | 1958       |
| N20-Toll:                         | 3                 | N54-Min Vert Under Clr (feet):    | N 0    | N106-Year of Reconstruction: | 0000       |
| N28-Lanes On / Under:             | 2 / 0             | N55-Min Lat Under Clr Rt (feet):  | N 99.9 | A204-Orig Project Number:    | F-022-1(1) |
|                                   | <i>2nd Record</i> | N56-Min Lat Under Clr Lt (feet):  | 0      | A205-Orig Project Station:   | 3045+14.34 |
| N5-Inv Rte:                       | 1 2 0 00060 0 -   |                                   |        | A223-TRACS Number:           |            |
| N10-Inv Rte Min Vert Clr (feet):  | 99.99             |                                   |        | A225-Deck Area (sq. feet):   | 0          |
| N11-Inv Rte Milepoint:            | 56.85             |                                   |        | A226-Superstr Unit Cost:     | \$0        |
| N26-Functional Class:             | 07                |                                   |        | A227-Substr Unit Cost:       | \$0        |
| N29-Avg Daily Traffic:            | 2417              |                                   |        |                              |            |
| N30-Year of ADT:                  | 1998              |                                   |        |                              |            |
| N47-Inv Rte Tot Horiz Clr (feet): | 39                |                                   |        |                              |            |
| N100-Defense Hwy:                 | 0                 |                                   |        |                              |            |
| N101-Parallel Bridge:             | N                 |                                   |        |                              |            |
| N102-Direction of Traffic:        | 2                 |                                   |        |                              |            |
| N104-Hwy System:                  | 0                 |                                   |        |                              |            |
| N109-Percent Truck Traffic:       | 46                |                                   |        |                              |            |
| N110-National Truck Network:      | 1                 |                                   |        |                              |            |
| N114-Future ADT:                  | 2427              |                                   |        |                              |            |
| N115-Year of Future ADT:          | 2020              |                                   |        |                              |            |
| N200-Is N5 the Princ. Rte?        | Y                 |                                   |        |                              |            |

| SERVICE, TYPE, and SPAN INFORMATION |     | CONDITION RATINGS   |   | INSPECTION               |                 |
|-------------------------------------|-----|---------------------|---|--------------------------|-----------------|
| N42-Service Type:                   | 15  | N58-Deck:           | 8 | N90-Inspection Date:     | 2/1/2000        |
| N43-Str Type, Main:                 | 219 | N59-Superstructure: | N | N91-Insp Freq (months):  | 48              |
| N44-Str Type, Appr:                 | 000 | N60-Substructure:   | N | A207-Inspection Quarter: | 1               |
| N45-Number of Main Spans:           | 3   | N61-Channel:        | 7 | A208-Inspection Number:  | 14              |
| N46-Number of Appr Spans:           | 0   | N62-Culvert:        | 7 | A228-Next Insp Date:     | Quarter 1, 2004 |

| APPRAISAL RATINGS            |         | CRITICAL FEATURES                   |     |
|------------------------------|---------|-------------------------------------|-----|
| N67-Struct Evaluation:       | 7       | N92A-Fracture Critical:             | N 0 |
| N68-Deck Geometry:           | 5       | N92B-Underwater Insp:               | N 0 |
| N69-Underclearance Rtg:      | N       | N92C-Special Insp:                  | N 0 |
| N71-Waterway Adequacy:       | 6       | N93A-Date Fract Crit Insp:          | 0   |
| N72-Appr Rdw Align:          | 8       | N93B-Date Underwtr Insp:            | 0   |
| N36-Traffic Safety Features: | 0 0 0 0 | N93C-Date Spec Insp:                | 0   |
|                              |         | A234-Steel In-Depth Insp Freq (mo): | 0   |

| BRIDGE SCOUR DATA          |       | CULVERT INFORMATION            |    |
|----------------------------|-------|--------------------------------|----|
| N113-Scour Critical Rtg:   | 8     | A217-Culv Barrel Height (feet) | 6  |
| A202-Foundation Type:      |       | A218-Culv Length (feet):       | 41 |
| A220-Found Embed (feet):   | 0     | A219-Culv Fill Height (feet):  | 1  |
| A221-Scour Countermeasure: | 0 1 0 |                                |    |

| LOAD, RATE, and POST                |        | BRIDGE RAILING            |   |
|-------------------------------------|--------|---------------------------|---|
| N31-Design Loading:                 | 5      | A206a-Bridge Rail Type:   | 6 |
| N41-Open, Post, Close:              | A      | A206b-Geometric Conform:  | 0 |
| N63-Method Used for Oper. Rtg.:     | 5      | A206c-Structural Conform: | 0 |
| N64-Operating Load Rtg:             | 2 - 36 |                           |   |
| N65-Method Used for Inv. Rtg.:      | 5      |                           |   |
| N66-Inventory Load Rtg:             | 2 - 36 |                           |   |
| N70-Bridge Posting:                 | 5      |                           |   |
| N103-Temp Str Designation:          |        |                           |   |
| A211-Posted Limit (Tons):           | 0      |                           |   |
| A222-Date of Load Rtg:              | -      |                           |   |
| A233-Posted Vert Clr NB/EB (ft-in): | 0 - 0  |                           |   |
| A233-Posted Vert Clr SB/WB (ft-in): | 0 - 0  |                           |   |

| SUFFICIENCY RATING  |       | GENERAL COMMENTS |  |
|---------------------|-------|------------------|--|
| Sufficiency Rating: | 92.32 |                  |  |

| RESPONSIBILITY            |      | NAVIGATION                   |   | GENERAL DATA                      |       |
|---------------------------|------|------------------------------|---|-----------------------------------|-------|
| I21-Maint Responsibility: | 01   | 38-Navigation Control:       | 0 | 33-Bridge Median:                 | 0     |
| I22-Bridge Owner:         | 01   | 39-Nav Vert Clr (feet):      | 0 | 34-Skew:                          | 0     |
| I203-ADOT Org Number:     | 8852 | 40-Nav Horiz Clr (feet):     | 0 | 35-Structure Flared:              | 0     |
| I224-Insp Team Number:    | 4    | 111-Nav Pier/Abut Prot:      |   | 37-Historical Significance:       | 5     |
| I229-Agency:              | ADOT | 116-Nav Min Vert Clr (feet): | 0 | 107-Deck Str Type:                | 1     |
|                           |      |                              |   | 108-Wear Surf Prot System:        | 6 0 0 |
|                           |      |                              |   | 201-Wear Surf Thickness (inches): | 4     |

Figure 4.1.4 Arizona Structural Inventory and Appraisal Sheet

REPORT ID: INVT001A

FLORIDA DEPARTMENT OF TRANSPORTATION  
 BRIDGE MANAGEMENT SYSTEM  
 COMPREHENSIVE INVENTORY DATA REPORT

Page 1 of 4

Structure ID: 520002

**4 Description**

Structure Unit Identification

Bridge/Unit ID 520002 0  
 Description MAIN SPAN 1  
 Type Main Span  
 NBI Unit Flag Main  Approach   
 Curb/Sidewalk (50) Left 0 ft Right 0 ft  
 Deck width (52) 0 ft  
 Bridge Median (33) No median

Roadway Identification:

NBI Structure No (8) 520002  
 Position/Prefix (5) Route On Structure  
 Kind Hwy (Rte Prefix) U.S. Numbered Hwy  
 Design Level of Service Mainline  
 Route Number/Suffix 00090 / Not Applicable  
 Feature Intersect (6) US90 SR10/GUM CREEK  
 Critical Facility Not Defense-crit  
 Facility Carried (7) US 90 SR 10  
 Mile Point (11) 20.815  
 Latitude (16) 030d47'39" Long (17) 085d43'28"

Roadway Classification

Nat. Hwy Sys (104) Not on NHS  
 National base Net (12) On Base Network  
 LRS Inventory Rte (13a) 52 010 000 Sub Rte (13b) 00  
 Functional Class (26) Rural Minor Arterial  
 Eligible for Federal Aid ? Yes  
 Defense Hwy (100) Not a STRAHNET hwy  
 Direction of Traffic (102) 2-way traffic  
 Critical Travel Route

Structure Unit Type and Material

Struct Material (43) Concrete  
 Design Type Culvert  
 Deck Type (107) Not Applicable  
 Surface (108) Not Applicable  
 Membrane None  
 Deck Protection None  
 Skew (34) 0 deg

Roadway Traffic and Accidents

Lanes (28) 2 Medians 0 Speed 54.681 mph  
 ADT Class ADT Class 3  
 Recent ADT (29) 5100 Year (30) 1998  
 Future ADT (114) 9490 Year (115) 2020  
 Truck % ADT (109) 7  
 Detour Length (19) 1.243 mi  
 Detour Speed 44.739 mph  
 Accident Count -1 Rate -1

Roadway Clearances

Vertical (10) 99.99 ft Appr. Road (32) 34.121 ft  
 Horiz. (47) 34.121 ft Roadway (51) 0 ft  
 Truck Network (110) Not part of natl network  
 Toll Facility (20) On free road  
 Fed. Lands Hwy (105) Not Applicable  
 School Bus Route   
 Transit Route

**Figure 4.1.5** Florida Structural Inventory and Appraisal Sheet



REPORT ID: INVT001A

FLORIDA DEPARTMENT OF TRANSPORTATION  
 BRIDGE MANAGEMENT SYSTEM  
 COMPREHENSIVE INVENTORY DATA REPORT

Page 2 of 4

Structure ID: 520002

**Structure Identification**

Admin Area Not located in area  
 District (2) D3 - Chipley  
 County (3) (52)Holmes  
 Place Code (4) No city involved  
 Location (9) 3.2 KM W OF BONIFAY  
 Border Br St/Reg (98) Not Applicable Share 0 %  
 Border Struct No (99)  
 FIPS State/Region (1) Florida Region 4-Atlanta  
 NBIS Bridge Len (112) Meets NBI Length  
 Parallel Structure (101) No II bridge exists  
 Temp. Structure (103) Not Applicable  
 Maint. Resp. (21) State Highway Agency  
 Owner (22) State Highway Agency  
 Historic Signif. (37) Not eligible for NRHP

**Geometrics**

Spans in Main Unit (45) 4  
 Approach Spans (46) 0  
 Length of Max Span (48) 9.843 ft  
 Structure Length (49) 42.979 ft  
 Deck Area -1 sqft  
 Structure Flared (35) No flare

**Age and Service**

Year Built (27) 1954  
 Year Reconstructed (106) -1  
 Type of Service On (42a) Highway  
 Under (42b) Waterway  
 Fracture Critical Details Not Applicable

**3 Appraisal**

**Structure Appraisal**

Open/Posted/Closed (41) Open, no restriction  
 Deck Geometry (68) Not Applicable  
 Underclearances (69) Not Applicable  
 Approach Alignment (72) No speed red thru curve  
 Bridge Railings (36a) Not Applicable  
 Transitions (36b) Not Applicable  
 Approach Guardrail (36c) Meets Standards  
 Approach Guardrail ends (36d) Meets Standards  
 Scour Critical (113) Stable Above Footing

**Navigation Data**

Navigation Control (38) Permit Not Required  
 Nav Vertical Clr (39) 0 ft  
 Nav Horizontal Clr (40) 0 ft  
 Min Vert Lift Clr (116) 0 ft  
 Pier Protection (111) Not Applicable

**NBI Condition Rating**

Sufficiency Rating \* 99.5  
 Structural Eval (67) Above Min Criteria  
 Deficiency Not Deficient

**Minimum Vertical Clearance**

Over Structure (53) 99.99 ft  
 Under (reference) (54a) Feature not hwy or RR  
 Under (54b) 0 ft

**Minimum Lateral Underclearance**

Reference (55a) Feature not hwy or RR  
 Right Side (55b) 0 ft  
 Left Side (56) 0 ft

**Load Rating**

Design Load (31) M 13.5 (H 15)  
 Rating Date 08/08/1994 Initials JF  
 Posting (70) At/Above Legal Loads

Operating Type (63) LF Load Factor  
 Operating rating (64) 68.894 tons Alternate -1  
 Inventory Type (65) LF Load Factor  
 Inventory Rating (66) 40.896 tons Alternate -1  
 Alt Meth -1

**6 Schedule**

**Current Inspection**

Inspection Date 01/06/2000  
 Inspector MT338TK - Tom Klopfenstein  
 Primary Type Regular NBI  
 Review Required

**Next Inspection Date Scheduled**

NBI 01/06/2002  
 Element 01/06/2002  
 Fracture Critical  
 Underwater  
 Other Special

**Inspection Types**

**Performed** NBI  Element  Fracture Critical  Underwater  Other Special

Figure 4.1.5 Florida Structural Inventory and Appraisal Sheet (Continued)



Structure ID: 520002

| <u>Inspection Intervals</u> | <u>Required (92)</u>     | <u>Frequency (92)</u> | <u>Last Date (93)</u> | <u>Inspection Resources</u> |
|-----------------------------|--------------------------|-----------------------|-----------------------|-----------------------------|
| Fracture Critical           | <input type="checkbox"/> | mos                   |                       | Crew Hours 8                |
| Underwater                  | <input type="checkbox"/> | mos                   |                       | Flagger Hours 0             |
| Other Special               | <input type="checkbox"/> | mos                   |                       | Helper Hours 0              |
| NBI                         |                          | 24 mos (91)           | 01/06/2000 (90)       | Snooper Hours 0             |
|                             |                          |                       |                       | Special Crew Hours 0        |
|                             |                          |                       |                       | Special Equip Hours 0       |

**5 Custom**

General Bridge Information

|                             |  |
|-----------------------------|--|
| Parallel Bridge Seq         | Bridge Rail 1 Not applicable-No rail   |
| Channel Depth 0.328 ft      | Bridge Rail 2 Not applicable-No rail   |
| Radio Frequency -1          | Electrical Devices No electric service |
| Phone Number (000) 000-0001 | Culvert Type Not applicable            |
| Exception Date              | Maintenance Yard Marianna Yard         |
| Exception Type Unknown      |  |

Bridge Load Rating Information

|                                   |  |
|-----------------------------------|--|
| Govr. Span Length 9.843 ft        | Single Unit Truck 2 Axles 48.502 tons      |
| L-Rating Origination Design Plans | Single Unit Truck 3 Axles 60.627 tons      |
| Load Rating Date 08/08/1994       | Single Unit Truck 4 Axles 74.957 tons      |
| Method Calculation AASHTO formula | Combination Unit Truck 3 Axles 79.366 tons |
| Load Dist. Factor 0.168           | Combination Unit Truck 4 Axles 79.366 tons |
| Impact Factor 0                   | Combination Unit Truck 5 Axles 87.083 tons |
| Design Method Load Factor         | Truck Trailer 5 Axles 95.901 tons          |
| Design Measure English            | Posting Weight tons                        |
| Recommended Single Unit -1 tons   | Posting Single Unit -1 tons                |
| Recommended Combination -1 tons   | Posting Combination Unit -1 tons           |
| Recommended Tandem -1 tons        | Posting Tandem Unit -1 tons                |

Bridge Scour and Storm Information

|                                      |  |
|--------------------------------------|--|
| Pile Driving Record Not Applicable   | Scour Recommended I Stop scour evaluations |
| Foundation Type Foundation details   | Scour Recommended II Unknown               |
| Mode of Flow Riverine                | Scour Recommended III Unknown              |
| Rating Scour Eval Low Risk - Low     | Scour Elevation -1 ft                      |
| Highest Scour Eval Phase I completed | Action Elevation -1 ft                     |
|                                      | Storm Frequency -1                         |

**1 Condition**

NBI Rating

|                                    |  |
|------------------------------------|--|
| Channel (61) No Deficiencies       | Culvert (62) Minor Deterioration         |
| Deck (58) Not Applicable           | Waterway (71) 8 - Equal Desirable        |
| Superstructure (59) Not Applicable | Unrepaired Spalls -1 sq.ft.              |
| Substructure (60) Not Applicable   | Review Required <input type="checkbox"/> |

**Figure 4.1.5** Florida Structural Inventory and Appraisal Sheet (Continued)

REPORT ID: INVT001A

FLORIDA DEPARTMENT OF TRANSPORTATION  
 BRIDGE MANAGEMENT SYSTEM  
 COMPREHENSIVE INVENTORY DATA REPORT

Page 4 of 4

Structure ID: 520002

Elements

Inspection Date: 01/06/2000 GKXW

| Span Id | Elem/ErDescription | Qty1 | %1  | Qty2 | %2 | Qty3 | %3 | Qty4 | %4 | Qty5 | %5 | T Qty |
|---------|--------------------|------|-----|------|----|------|----|------|----|------|----|-------|
| 0       | 290/4 Channel      | 1    | 100 | 0    | 0  | 0    | 0  | 0    | 0  | 0    | 0  | 1 ea. |

Notes

|   |                    |     |     |   |   |   |   |   |   |   |   |         |
|---|--------------------|-----|-----|---|---|---|---|---|---|---|---|---------|
| 0 | 475/4 R/Conc Walls | 154 | 100 | 0 | 0 | 0 | 0 | 0 | 0 | 0 | 0 | 154 lf. |
|---|--------------------|-----|-----|---|---|---|---|---|---|---|---|---------|

Notes

|   |                        |     |    |    |    |   |   |   |   |   |   |         |
|---|------------------------|-----|----|----|----|---|---|---|---|---|---|---------|
| 0 | 241/4 Concrete Culvert | 299 | 82 | 66 | 18 | 0 | 0 | 0 | 0 | 0 | 0 | 364 lf. |
|---|------------------------|-----|----|----|----|---|---|---|---|---|---|---------|

Notes There are a few vertical cracks in the side walls of the original section of culvert.

Total Number of Elements: 3

Past Inspections

Inspection Date: 01.06.2000

Type: Regular NBI

Inspector: MT338TK - Tom Klopfenstein

Inspection Notes: Sufficiency Rating Calculation Accepted by mt338tk at 01/10/2000 13:45:43  
 MT338TK inspection comments - The left extended portion of culvert is skewed 24 degrees to the left due to stream alignment.  
 Structure 520002 -  
 Date 01/06/2000 -  
 Previous comments > (none)

Inspection Date: 04.01.1998

Type: Regular NBI

Inspector: BID

Inspection Notes:

Bridge Notes

**Figure 4.1.5** Florida Structural Inventory and Appraisal Sheet (Continued)

Some agencies furnish standardized sketch sheets and photo sheets to inspectors for report generation. Some agencies have developed their forms on software packages for use on portable computers (see Figures 4.1.6 and 4.1.7) or wearable computers (see Figures 4.1.8 and 4.1.9).



**Figure 4.1.6** Portable Computer



**Figure 4.1.7** Inspector Using Portable Computer



**Figure 4.1.8** Wearable Computer with Case



**Figure 4.1.9** Inspector Using Wearable Computer



The data and information required of states by the FHWA is listed in the *FHWA Coding Guide* and *AASHTO Manual for Bridge Evaluation*. It is important to note that several items listed in the *FHWA Coding Guide* apply to both the field and office personnel responsible for bridge inspections. The bridge inspector is typically not required to obtain the data for all the items during every inspection of a bridge. Once a bridge has been inventoried, the majority of the geometric and other inventory items will remain unchanged. The inspector is responsible for spot checking to see if inventoried items are consistent with observations at the bridge site.

### 4.1.3

#### Inventory Items

---

Inventory items pertain to a bridge's characteristics. For the most part, these items are permanent characteristics, which only change when the bridge is altered in some way, such as reconstruction or load restriction. Inventory items include the following SI&A items:

- Identification – Identifies the structure using location codes and descriptions.
- Structure Type and Material – Categorizes the structure based on the material, design and construction, the number of spans, and wearing surface.
- Age and Service – Information showing when the structure was constructed or reconstructed, features the structure carries and crosses, and traffic information.
- Geometric Data – Includes pertinent structural dimensions.
- Navigation Data – Identifies the existence of navigation control, pier protection, and waterway clearance measurements.
- Classification – Classification of the structure and the facility carried by the structure are identified.
- Load Rating and Posting – Identifies the load capacity of the bridge and the current posting status. This item is subject to change as conditions change and is therefore not viewed as a "permanent" item.
- Proposed Improvements – Items for work proposed and estimated costs for all bridges eligible for funding from the Highway Bridge Program.
- Inspection – Includes latest inspection dates, designated frequency, and critical features requiring special inspections or special emphasis during inspection.

All inventory items are explained in the *FHWA Coding Guide*. Although inventory items are usually provided from previous reports, the inspector is responsible for verifying and updating the inventory data as needed. See Topic 4.2 for condition and appraisal rating items.

#### 4.1.4

### Condition and Appraisal Rating Items

**Condition Rating Items** Condition ratings are used to describe the existing, in-place bridge as compared to the as-built condition. Condition ratings are typically coded by the inspector. Condition rating items include:

- Deck – Describes the overall condition rating of the deck. This condition of the surface/protective systems, joints, expansion devices, curbs, sidewalks, parapets, fascias, bridge rail and scuppers is not included in the rating, but the condition will be noted in the inspection form. Decks that are integral with the superstructure will be rated as a deck only and not influence the superstructure rating.
- Superstructure – Describes the physical condition of all the structural members. The condition of the bearings, joints, paint system, etc. will not be included in the rating except for extreme situations, but the condition will be noted in the inspection form. Superstructures that are integral with the deck will be rated as a superstructure only and not influence the deck rating.
- Substructure – Describes the physical condition of piers, abutments, piles, fenders, footings or other components.
- Channel and channel protection – Describes the physical condition that is associated with the flow of the water through the bridge which include the stream stability and the condition of the hydraulic countermeasures.
- Culvert – Evaluates the alignment, settlement, joints, structural condition, scour and any other of the items that may be associated with a culvert.

**Appraisal Rating Items** Condition ratings are a judgment of a bridge component condition in comparison to current standards. Appraisal items are used to evaluate a bridge in relation to the level of service which it provides on the highway system of which it is a part. The structure will be compared to a new one which is built to current standards for that particular type of road. Appraisal rating items include:

- Structural Evaluation – Overall evaluation of the structure based on the lowest bridge component condition rating, excluding the deck, superstructure, substructure, channel and channel protection and culverts. This item is calculated by the FHWA Edit/Update program.
- Deck Geometry – Evaluates the curb-to-curb bridge roadway width and the minimum vertical clearance over the bridge roadway. This item is calculated by the FHWA Edit/Update program.
- Under-clearances, Vertical and Horizontal – The vertical and horizontal under-clearances from the through roadway under the structure to the superstructure or substructure units. This item is calculated by the FHWA Edit/Update program.
- Waterway Adequacy – Appraises waterway opening with respect to passage of flow under the bridge.
- Approach Roadway Alignment – Comparing the alignment of the bridge

approaches to the general highway alignment of the section of highway that the structure is on.

- Traffic Safety Features – Record information on bridge railings, transitions, approach guiderail, approach guiderail ends, so that evaluation of their adequacy can be made.
- Scour Critical Bridges – Identify the current status of the bridge regarding its vulnerability to scour.

### 4.1.5

---

#### **The Role of Inventory Items in Bridge Management Systems**

Inventory items are an important part of an owner's Bridge Management System (BMS). Bridge owners use the inventory items to help plan inspection, maintenance, and reconstruction of their bridges, as well as classify their bridges. There have been times when there has been a problem on a particular bridge and the owners used the inventory items of that bridge to search for the same potential problems that might exist on other bridges.

# Table of Contents

## Chapter 4 Bridge Inspection Reporting

---

|       |   |        |
|-------|---|--------|
| 4.2   | Condition and Appraisal .....                         | 4.2.1  |
| 4.2.1 | Introduction.....                                     | 4.2.1  |
| 4.2.2 | Condition Rating Items .....                          | 4.2.1  |
|       | Deck, Superstructure and Substructure .....           | 4.2.1  |
|       | Evaluating Elements .....                             | 4.2.1  |
|       | Evaluating Components.....                            | 4.2.1  |
|       | Component Condition Rating Guidelines.....            | 4.2.1  |
| 4.2.3 | Channel and Channel Protection Condition Ratings..... | 4.2.5  |
|       | General .....   | 4.2.5  |
|       | Overall Condition .....                               | 4.2.5  |
| 4.2.4 | Culvert Condition Ratings .....                       | 4.2.6  |
|       | General .....   | 4.2.6  |
|       | Evaluating Elements .....                             | 4.2.6  |
|       | Evaluating Components.....                            | 4.2.6  |
|       | Component Condition Rating Guidelines.....            | 4.2.6  |
| 4.2.5 | Appraisal Rating Items.....                           | 4.2.7  |
|       | Appraisal Rating Guidelines.....                      | 4.2.7  |
| 4.2.6 | Functionally Obsolete and Structurally Deficient..... | 4.2.11 |
|       | Definitions .....                                     | 4.2.11 |
|       | General Qualifications.....                           | 4.2.11 |
| 4.2.7 | Sufficiency Rating .....                              | 4.2.12 |
|       | Definition.....                                       | 4.2.12 |
|       | Sufficiency Rating Formula .....                      | 4.2.12 |
|       | Uses .....  | 4.2.12 |



This page intentionally left blank

# Topic 4.2 Condition and Appraisal

## 4.2.1

### Introduction

The reported condition of an element or component is an evaluation of its current physical state compared to what it was on the day it was built. Appraisal rating items are used to evaluate a bridge in relation to the level of service it provides on the highway system of which it is a part.

## 4.2.2

### Condition Rating Items

#### Deck, Superstructure and Substructure

Accurate assignment of condition ratings is dependent upon the bridge inspector's ability to identify the bridge components and their elements. Bridge components are the major parts comprising a bridge including the deck, superstructure, and substructure. Bridge elements are individual members comprised of basic shapes and materials connected together to form bridge components.

The overall condition rating of bridge components is directly related to the physical deficiencies of bridge elements.

#### Evaluating Elements

The inspector is responsible for evaluating each element of each component and assigning to it a descriptive condition rating of "good," "fair," or "poor," based on the physical deficiencies found on the individual element. The following guidelines are used in establishing an element's condition rating:

- Good - element is limited to only minor problems.
- Fair - structural capacity of element is not affected by minor deterioration, section loss, spalling, cracking, or other deficiency.
- Poor - structural capacity of element is affected or jeopardized by advanced deterioration, section loss, spalling, cracking, or other deficiency.

To ensure a comprehensive inspection and as a part of the requirements of record keeping and documentation, an inspector is responsible for recording the location, type, size, quantity, and severity of deterioration and deficiencies for each element of a given component.

#### Evaluating Components

The following major components of bridges receive an overall Structure Inventory and Appraisal (SI&A) component condition rating:

- Item No. 58 – Deck
- Item No. 59 – Superstructure
- Item No. 60 – Substructure

#### Component Condition Rating Guidelines

NBI component condition ratings for deck, superstructure, or substructure components, in general, should reflect the overall condition of the component rather than localized conditions. This has been true for many years and is emphasized in the FHWA *Coding Guide* with the following wording:

*Condition codes are properly used when they provide an overall characterization of the general condition of the entire component being rated. Conversely, they are improperly used if they attempt to describe localized or nominally occurring instances of deterioration or disrepair. Correct assignment of a condition code must, therefore, consider both the severity of the deterioration or disrepair and the extent to which it is widespread throughout the component being rated.*

Although the *FHWA Coding Guide* states that it is improper to use the condition codes to describe localized instances of deterioration or disrepair, it also states that the inspector must consider both the severity and extent of the deterioration. With this in mind, there are occasions when a severe, localized condition affects the structural capacity of a component member. It is important to recognize that the coding applies to all primary members of a component. Therefore, localized conditions that impact the structural capacity of just one member can impact the overall performance of the entire component. The affect on structural capacity is dependent upon several factors including the type and extent of the deterioration, as well as the location along the member. An inspector may need to discuss the observed condition with an engineer to make this determination. When these situations occur, it is appropriate to assign a lower component condition rating for that component from a safety perspective and is in keeping with the intent of the National Bridge Inspection Program.

When these localized conditions are determined to be such that prompt action is needed and/or the overall component condition rating is affected, the conditions should also be addressed through the "critical findings" process that is identified in the NBIS regulation. The NBI component condition rating should be reviewed and appropriately adjusted once the critical finding has been addressed. This adjustment will depend on how the critical finding was addressed and how that action relates to the original rating rationale.

The coding of NBI condition items should be viewed as important, but secondary, to the recognition of and follow-up on critical findings.

Currently, states employ two approaches to coding condition items when localized areas of severe deterioration are encountered. Some will account for the severity of a localized area of deterioration by lowering the condition rating of an entire component. The component condition rating is adjusted after the deteriorated area is improved (i.e., rating may rise if physical improvements are made, or may stay the same if the bridge is posted for load restrictions and/or supported with temporary shoring). FHWA recognizes this approach when the severity of the localized deterioration affects the structural capacity of the component.

Other states "rate to the average" regardless of the severity of a localized area of deterioration. This approach relies heavily on ensuring that critical findings are addressed in a timely manner regardless of the component condition rating value. If the localized area of severe deterioration is not improved following the critical finding follow-up process, the component condition rating may need to be lowered to account for the severity of the deterioration if structural capacity is affected.

Either approach to coding the condition items results in the same ultimate outcome, i.e. critical inspection findings are addressed to ensure continued safe use

of the bridge and component condition ratings eventually reflect the overall condition of the component. If the approach is to consider both the severity and extent of a component's deterioration in rating each component at the time of inspection (or up to 90 days after the inspection as required by the NBIS), there cannot be any assumptions about future improvements made to a localized area. Only if an improvement is made, the rating should then be raised as appropriate. If the improvement is made within 90 days of the inspection, there is no need to consider the localized deterioration in the rating.

The following general component condition rating guidelines (obtained from the 1995 edition of the *FHWA Coding Guide*) are to be used in the evaluation of the deck (Item 58), superstructure (Item 59), and substructure (Item 60):

| <u>Code</u> | <u>Description</u>  |
|-------------|---|
| N           | NOT APPLICABLE  |
| 9           | EXCELLENT CONDITION   |
| 8           | VERY GOOD CONDITION - no problems noted.  |
| 7           | GOOD CONDITION - some minor problems.   |
| 6           | SATISFACTORY CONDITION - structural elements show some minor deterioration.   |
| 5           | FAIR CONDITION - all primary structural elements are sound but may have minor section loss, cracking, spalling, or scour.   |
| 4           | POOR CONDITION - advanced section loss, deterioration, spalling, or scour.  |
| 3           | SERIOUS CONDITION - loss of section, deterioration, spalling, or scour have seriously affected primary structural components. Local failures are possible. Fatigue cracks in steel or shear cracks in concrete may be present.  |
| 2           | CRITICAL CONDITION - advanced deterioration of primary structural elements. Fatigue cracks in steel or shear cracks in concrete may be present or scour may have removed substructure support. Unless closely monitored it may be necessary to close the bridge until corrective action is taken. |
| 1           | "IMMINENT" FAILURE CONDITION - major deterioration or section loss present in critical structural components, or obvious vertical or horizontal movement affecting structure stability. Bridge is closed to traffic but corrective action may put bridge back in light service.                   |
| 0           | FAILED CONDITION - out of service; beyond corrective action.  |

The component condition rating guidelines presented above are general in nature and can be applied to all bridge components and material types.

Structural capacity is defined as the designed strength of the member. However, structural capacity is different than load-carrying capacity. Load-carrying capacity refers to the ability of the member to carry the legal loads of the highway system of which the bridge is a part. Therefore, a bridge could possibly have good structural capacity yet be load posted because it is unable to carry the legal loads.



A bridge's load-carrying capacity is not to influence component condition ratings. The fact that a bridge was designed for less than current legal loads, and may even be posted, has no influence upon component condition ratings.

Component condition ratings are determined by applying condition descriptions, which are general in nature, covering a broad array of bridge components and material types. The inspector is responsible for being familiar with terminology concerning material types and associated deficiency to utilize condition descriptions for accurately assigning component condition ratings. The following illustrates several common deficiency terms found in condition descriptions and their associated material types:

- Section loss usually applies to steel members or reinforcing steel
- Fatigue crack applies to steel members
- Cracking/spalling usually are used to describe concrete
- Shear crack usually applies to concrete but may apply to timber as well
- Checks/splits applies to timber members
- Scour can apply to substructure

Establishing a link between material type and deficiency allows for accurate component condition ratings determined by utilizing condition descriptions for ratings 9 through 1 found in the general component condition rating guidelines.

Supplemental component condition rating guidelines, which may be developed by individual states, are intended to be used in addition to the *FHWA Coding Guide* to make it easier for the inspector to assign the most appropriate condition rating to the component being considered and improve uniformity.

Using the material and component specific supplemental rating guidelines (found in the 1995 edition of the *FHWA Coding Guide*) helps to clarify how each type of deficiency affects the component condition rating. Care has to be taken not to "pigeonhole" the rating based on only one word or phrase. The following is one suggested method for determining proper component condition ratings:

- Identify phrases that describe the component
- Read through the rating scale until encountering phrases that describe conditions that are more severe than what actually exists
- Be sure to read down the ratings list far enough
- Correct rating number then is one number higher

This procedure generally works with all of the component condition rating guidelines.

### 4.2.3

## **Channel and Channel Protection Condition Ratings**

### **General**

For structures located over waterways, a Structure Inventory and Appraisal (SI&A) condition rating is provided for the channel and channel protection:

- Item No. 61 – Channel and Channel Protection

### **Overall Condition**

This item describes the physical conditions associated with the flow of water through the bridge such as stream stability and the condition of the channel, riprap, slope protection, or stream control devices, including spur dikes. The inspector should be particularly concerned with visible signs of excessive water velocity which may cause undermining of slope protection, erosion of banks, and realignment of the stream. Accumulation of drift and debris on the superstructure and substructure should be noted on the inspection form but not included in the component condition rating of the superstructure and substructure.

Evaluate and code the condition in accordance with the previously described general component condition ratings, procedures to account for critical findings, and the following descriptive codes:

#### Code   Description

- |   |  |
|---|--|
| N | Not applicable. Use when bridge is not over a waterway (channel).  |
| 9 | There are no noticeable or noteworthy deficiencies which affect the condition of the channel.  |
| 8 | Banks are protected or well vegetated. River control devices such as spur dikes and embankment protection are not required or are in a stable condition.   |
| 7 | Bank protection is in need of minor repairs. River control devices and embankment protection have a little minor deficiency. Banks and/or channel have minor amounts of drift.                             |
| 6 | Bank is beginning to slump. River control devices and embankment protection have widespread minor deficiency. There is minor streambed movement evident. Debris is restricting the channel slightly.       |
| 5 | Bank protection is being eroded. River control devices and/or embankment have major deficiency. Trees and brush restrict the channel.  |
| 4 | Bank and embankment protection is severely undermined. River control devices have severe deficiency. Large deposits of debris are in the channel.  |
| 3 | Bank protection has failed. River control devices have been destroyed. Streambed aggradation, degradation, or lateral movement has changed the channel to now threaten the bridge and/or approach roadway. |
| 2 | The channel has changed to the extent the bridge is near a state of collapse.  |
| 1 | Bridge closed because of channel failure. Corrective action may put bridge back in light service.  |

0 Bridge closed because of channel failure. Replacement necessary.

## 4.2.4

### Culvert Condition Ratings

#### General

When assigning a culvert condition rating, all areas of the culvert and the possible effects on the overall structure are investigated. The inspector considers whether the component is functioning properly, whether it could pose a threat to safety or cause property damage, and whether it could cause more extensive damage if not repaired.

#### Evaluating Elements

Chapter 14 addresses the individual elements of various culverts. The overall component condition rating considers all of the elements which make up a culvert and are useful in establishing maintenance, rehabilitation, and replacement programs and priorities.

Although some of the individual elements of culverts are not directly considered in the *FHWA Coding Guide*, these supplemental items are useful in determining the overall culvert condition ratings. They may also be included as part of an agency's bridge management system.

#### Evaluating Components

In addition to the major components of bridges (deck, superstructure, and substructure), culverts also receive a Structure Inventory and Appraisal (SI&A) overall component condition rating:

➤ Item No. 62 – Culverts

#### Component Condition Rating Guidelines

This item evaluates the alignment, settlement, joints, structural condition, scour, and other items associated with culverts. The component condition rating code is intended to be an overall condition evaluation of the culvert. Integral wingwalls to the first construction or expansion joint are included in the evaluation.

Item 58 – Deck, Item 59 – Superstructure, and Item 60 – Substructure should be coded N for all culverts.

Evaluate and code the culvert condition in accordance with the previously described general component condition ratings, procedures to account for critical findings and the following descriptive codes:

| <u>Code</u> | <u>Description</u> |
|-------------|--------------------|
|-------------|--------------------|

|   |  |
|---|--|
| N | Not applicable. Use if structure is not a culvert. |
|---|--|

|   |                  |
|---|------------------|
| 9 | No deficiencies. |
|---|------------------|

|   |   |
|---|---|
| 8 | No noticeable or noteworthy deficiencies which affect the condition of the culvert. Insignificant scrape marks caused by drift. |
|---|---|

|   |   |
|---|---|
| 7 | Shrinkage cracks, light scaling, and insignificant spalling which does not expose reinforcing steel. Insignificant damage caused by drift with no misalignment and not requiring corrective action. Some minor scouring |
|---|---|

- has occurred near curtain walls, wingwalls, or pipes. Metal culverts have a smooth symmetrical curvature with superficial corrosion and no pitting.
- 6 Deterioration or initial disintegration, minor chloride contamination, cracking with some leaching, or spalls on concrete or masonry walls and slabs. Local minor scouring at curtain walls, wingwalls, or pipes. Metal culverts have a smooth curvature, non-symmetrical shape, significant corrosion, or moderate pitting.
  - 5 Moderate to major deterioration or disintegration, extensive cracking and leaching, or spalls on concrete or masonry walls and slabs. Minor settlement or misalignment. Noticeable scouring or erosion at curtain walls, wingwalls, or pipes. Metal culverts have significant distortion and deflection in one section, significant corrosion or deep pitting.
  - 4 Large spalls, heavy scaling, wide cracks, considerable efflorescence, or opened construction joint permitting loss of backfill. Considerable settlement or misalignment. Considerable scouring or erosion at curtain walls, wingwalls, or pipes. Metal culverts have significant distortion and deflection throughout, extensive corrosion or deep pitting.
  - 3 Any condition described in Code 4 but which is excessive in scope. Severe movement or differential settlement of the segments, or loss of fill. Holes may exist in walls or slabs. Integral wingwalls nearly severed from culvert. Severe scour or erosion at curtain walls, wingwalls, or pipes. Metal culverts have extreme distortion and deflection in one section, extensive corrosion, or deep pitting with scattered perforations.
  - 2 Integral wingwalls collapsed, severe settlement of roadway due to loss of fill. Section of culvert may have failed and can no longer support embankment. Complete undermining at curtain walls and pipes. Corrective action required to maintain traffic. Metal culverts have extreme distortion and deflection throughout with extensive perforations due to corrosion.
  - 1 Bridge closed. Corrective action may put bridge back in light service.
  - 0 Bridge closed. Replacement necessary.

## 4.2.5

### Appraisal Rating Items

#### Appraisal Rating Guidelines

The following SI&A items are known as appraisal rating items:

- Item No. 67 – Structural Evaluation
- Item No. 68 – Deck Geometry
- Item No. 69 – Underclearances, Vertical and Horizontal
- Item No. 71 – Waterway Adequacy
- Item No. 72 – Approach Roadway Alignment
- Item No. 36 – Safety Features
- Item No. 113 – Scour Critical Bridges

Appraisal rating items are used to evaluate a bridge in relation to the level of

service it provides on the highway system of which it is a part. The level of service for a bridge describes the function the bridge provides for the highway system carried by the bridge. The structure is compared to a new one that is built to current standards for that particular class of road. The exception is Item 72, Approach Roadway Alignment. Rather than comparing the alignment to current standards, it is compared to the general existing alignment of the roadway approaches to the bridge compared to the general highway.

The level of service goals used to appraise bridge adequacy vary depending on the highway functional classification, traffic volume, and other factors. The goals are set with the recognition that widely varying traffic needs exist throughout highway systems. Many bridges on local roads can adequately serve traffic needs with lower load capacity and geometric standards than would be necessary for bridges on heavily traveled main highways.

If national uniformity and consistency are to be achieved, similar structure, roadway, and vehicle characteristics are evaluated using identical standards. Therefore, tables and charts have been developed which are used to evaluate the appraisal rating items for all bridges submitted to the National Bridge Inventory, regardless of individual state criteria used to evaluate bridges.

The following general appraisal rating guidelines (obtained from the 1995 edition of the *FHWA Coding Guide*) are used to evaluate structural evaluation (Item 67), deck geometry (Item 68), underclearances (Item 69), waterway adequacy (Item 71) and approach roadway alignment (Item 72).

Code    Description

|   |   |
|---|---|
| N | Not applicable  |
| 9 | Superior to present desirable criteria                                      |
| 8 | Equal to present desirable criteria   |
| 7 | Better than present minimum criteria  |
| 6 | Equal to present minimum criteria   |
| 5 | Somewhat better than minimum adequacy to tolerate being left in place as is |
| 4 | Meets minimum tolerable limits to be left in place as is                    |
| 3 | Basically intolerable, requiring high priority of corrective action         |
| 2 | Basically intolerable, requiring high priority of replacement               |
| 1 | This value of rating code not used  |
| 0 | Bridge closed   |

The specific tables for Item 67 - Structural Evaluation, Item 68 - Deck Geometry, Item 69 - Underclearances, Vertical and Horizontal, Item 71 - Waterway Adequacy and Item 72 - Approach Roadway Alignment appear in the *FHWA Coding Guide* and are detailed enough that several states now program their computerized bridge management system to automatically calculate several of the appraisal rating items. Thus, some inspectors may not be responsible for coding these items. Inspectors may be asked to field verify the computed appraisal ratings.



Item 67 - Structural Evaluation - The item description and procedures used to determine the Structural Evaluation Appraisal Rating are located in Item 67 of the *FHWA Coding Guide*. This item is coded by the FHWA Edit/Update program, not the inspector. The correct way to evaluate this item for bridges is to consider the following factors:

- The lowest rating dictated by Item 59 - Superstructure, Item 60 - Substructure or Comparison of Item 29 - ADT and Item 66 - Inventory Rating.
- For culverts, the lower of Item 62 - Culverts or Comparison of Item 29 - ADT and Item 66 - Inventory Rating.
- Appraisal codes of 3 or less can be achieved without the superstructure and substructure controlling with the comparison of Item 29 – ADT and Item 66 – Inventory rating

Item 68 - Deck Geometry - The deck geometry appraisal evaluates the curb to curb bridge roadway width and the minimum vertical clearance over the bridge roadway. This item is coded by determining two appraisal ratings, one for bridge roadway width and one for the minimum vertical clearance. The lower of these two is the appraisal rating. This item is coded by the FHWA Edit/Update program, not the inspector. The *FHWA Coding Guide* includes the following scenarios to choose from for the bridge roadway width appraisal:

- Bridges with two lanes carrying two-way traffic.
- Bridges with one lane carrying two-way traffic.
- All other two-way traffic situations.
- Bridges with one-way traffic.

Item 69 - Underclearances, Vertical and Horizontal - This item refers to the vertical and horizontal underclearances from the through roadway under the structure to the superstructure or substructure units. The item description and coding guidelines, which are located in Item 69 of the *FHWA Coding Guide*, are used to determine the Underclearance Appraisal Rating. This item is similar to Item 68 in that two different ratings are developed: one for vertical underclearance and one for horizontal underclearance. The lower of these two is the appraisal rating. This item is coded by the FHWA Edit/Update program, not the inspector.

Item 71 - Waterway Adequacy - Waterway adequacy is appraised with respect to passage of flow through the bridge. The rating is tied to flood frequencies and traffic delays. Appraisal ratings are assigned by the table contained in Item 71 of the *FHWA Coding Guide* and are based on the functional classification of the road carried by the structure, hydraulic and traffic data for the structure, and site conditions. This item is not coded by the FHWA Edit/Update program.

Item 72 - Approach Roadway Alignment – This appraisal is based on comparing the alignment of the bridge approaches to the general highway alignment of the section of roadway on which the structure is located. The rating guidelines are correctly applied by determining if the vertical or horizontal curvature of the bridge approaches differs from the section of highway the bridge is on, resulting in a reduction of vehicle operating speed to cross the bridge. This item is not coded by the FHWA Edit/Update program. The guidelines for FHWA Item 72, Appraisal or

Approach Roadway Alignment, are as follows:

- If no reduction in the operating speed of a vehicle is required compared to the highway, code Item 72 as an “8.”
- If only a very minor reduction in the operating speed of a vehicle is required compared to the highway, code Item 72 as a “6.”
- If a substantial reduction in the operating speed of a vehicle is required compared to the highway, code Item 72 as a “3.”

The following guidelines indicate a means of determining the difference between a minor reduction and substantial reduction of operating speed:

- Minor reduction in operating speed -  $\leq 9$  mph
- Substantial reduction in operating speed -  $\geq 10$  mph

The remaining codes between these general values are applied at the inspector’s discretion.

A narrow bridge does not affect the Approach Roadway Alignment Appraisal. The narrow bridge would be accounted for in Item 68, Deck Geometry.

Items affecting sight distance at the bridge, unrelated to vertical and horizontal curvature of the roadway, such as vegetation growth and substructure units of overpass structures do not affect the Approach Roadway Alignment Appraisal.

Item 36 - Traffic Safety Features - For structures on the National Highway System (NHS), this appraisal is based on comparing the traffic safety features in place at the bridge site to current national standards set by regulation, so that an evaluation of their adequacy can be made. For structures not on the National Highway System (NHS), the procedure is the same, however, it shall be the responsibility of the highway agency (state, county, local, or federal) to set standards. The item description and procedures used to determine the Traffic Safety Feature Appraisal Rating are located in Item 36 of the *FHWA Coding Guide*. The following are the traffic safety features to be coded:

- Bridge Railings
- Transitions
- Approach Guiderail
- Approach Guiderail Ends

Item 113 - Scour Critical Bridges – This item is used to identify the current status of the bridge regarding its vulnerability to scour. A scour critical bridge is one with abutment or pier foundations that are rated as unstable due to observed scour at the bridge site, or a scour potential as determined from a scour evaluation study including a scour analysis made by hydraulic, geotechnical, or structural engineers. The item description, procedures, and code descriptions are located in Item 113 of the *FHWA Coding Guide*.

## 4.2.6

### **Functionally Obsolete and Structurally Deficient**

#### **Definitions**

A bridge is considered to be functionally obsolete if it has deck geometry, load carrying capacity, clearance or approach roadway alignment that no longer meets the criteria for the system of which the bridge is a part. Examples include bridges with inadequate lane widths or shoulder widths, insufficient vertical clearances to serve the traffic demand, or bridges that may be occasionally flooded.

Bridges are considered structurally deficient where significant load carrying elements are found to be in poor or worse condition due to deterioration and/or damage, or the adequacy of the waterway opening provided by the bridge is determined to be extremely insufficient to the point of causing intolerable traffic interruptions.

Any bridge classified as structurally deficient is excluded from the functionally obsolete category. Bridges that are structurally deficient and functionally obsolete are reported together as deficient bridges.

#### **General Qualifications**

In order to be considered for either the structurally deficient or functionally obsolete classification, a highway bridge must meet the following:

##### Structurally Deficient (SD) -

1. A condition rating of 4 or less for
  - Item 58 - Deck; or
  - Item 59 - Superstructures; or
  - Item 60 - Substructures; or
  - Item 62 - Culvert and Retaining Walls.<sup>(1)</sup> or
2. An appraisal rating of 2 or less for
  - Item 67 - Structural Evaluation; or
  - Item 71 - Waterway Adequacy.<sup>(2)</sup>

##### Functionally Obsolete (FO) -

1. An appraisal rating of 3 or less for
  - Item 68 - Deck Geometry; or
  - Item 69 - Underclearances;<sup>(3)</sup> or
  - Item 72 - Approach Roadway Alignment. or
2. An appraisal rating of 3 for
  - Item 67 - Structural Evaluation; or
  - Item 71 - Waterway Adequacy.<sup>(2)</sup>

Footnotes for structurally deficient and functionally obsolete:

- (1) Item 62 applies only if the last digit of Item 43 (Structure Type) is coded 19.
- (2) Item 71 applies only if the last digit of Item 42 (Type of Service) is coded 0, 5, 6, 7, 8 or 9.
- (3) Item 69 applies only if the last digit of Item 42 is coded 0, 1, 2, 4, 6, 7 or 8.

## 4.2.7

### Sufficiency Rating

#### Definition

Sufficiency rating (S.R.) is a calculated numeric value used to indicate the sufficiency of a bridge to remain in service. The rating is calculated using the sufficiency rating formula. Sufficiency rating is discussed in detail in Appendix B of the *FHWA Coding Guide*.

#### Sufficiency Rating Formula

$$S.R. = S_1 + S_2 + S_3 - S_4$$

$$0 \leq S.R. \leq 100$$

(entirely deficient)                      (entirely sufficient)

where:  $S_1$  = 55% max.; based on structural adequacy and safety (i.e., superstructure, substructure or culvert condition and load capacity).

$S_2$  = 30% max.; deals with serviceability and functional obsolescence (items such as deck condition, structural evaluation, deck geometry, underclearances, waterway adequacy, approach road alignment).

$S_3$  = 15% max.; concerns essentiality for public use (items such as detour length, average daily traffic, and STRAHNET (Strategic Highway Corridor Network)).

$S_4$  = 13% max.; deals with special reductions based on detour length, traffic safety features, and structure type.

Twenty NBI items are used to calculate these four factors which therefore determine the sufficiency rating. Sufficiency rating is not normally calculated manually. Usually, it is included in the agency's inventory computer program and is calculated automatically by the computer based upon the inventory data collected by the bridge inspector. The sufficiency rating is calculated by the FHWA Edit/Update program.

#### Uses

Sufficiency Rating (SR) is used by the federal and state agencies to determine the relative sufficiencies of all of the nation's bridges. In the recent past, eligibility for federal funding with Highway Bridge Program funds has been determined by the following criteria:

$$S.R. \leq 80 \quad \text{Eligible for rehabilitation}$$

S.R. < 50      Eligible for replacement

Some states use the sufficiency rating as the basis for establishing priority for repair or replacement of bridges; the lower the rating, the higher the priority. Several states have developed specific bridge management procedures with priority guidelines for repair or replacement of bridges. By using these types of procedures, priority ratings can be established by considering the significance or impact of such level-of-service parameters as traffic volume and class of highway.



This page intentionally left blank.

# Table of Contents

## Chapter 4 Bridge Inspection Reporting

---

|       |  |        |
|-------|--|--------|
| 4.3   | Introduction to Element Level Evaluation .....                       | 4.3.1  |
| 4.3.1 | Introduction.....  | 4.3.1  |
| 4.3.2 | Element Level Inspection Development .....                           | 4.3.1  |
| 4.3.3 | Element Level Rating Terminology.....                                | 4.3.3  |
| 4.3.4 | Basic Requirements of National Bridge Elements.....                  | 4.3.4  |
| 4.3.5 | Bridge Element Identification.....                                   | 4.3.5  |
|       | National Bridge Elements.....  | 4.3.5  |
|       | Bridge Management Elements .....                                     | 4.3.7  |
|       | Defect Flags.....  | 4.3.9  |
|       | Agency Developed Elements .....                                      | 4.3.10 |
|       | Agency Defined Subsets of NBEs .....                                 | 4.3.10 |
|       | Agency Defined Subsets of BMEs.....                                  | 4.3.10 |
|       | Independent Agency Developed Elements .....                          | 4.3.10 |
| 4.3.6 | Condition States .....   | 4.3.11 |
| 4.3.7 | Feasible Actions.....  | 4.3.11 |
| 4.3.8 | Environments .....   | 4.3.12 |
| 4.3.9 | The Role of Element Level Data in Bridge Management<br>Systems ..... | 4.3.12 |

This page intentionally left blank

# Topic 4.3 Introduction to Element Level Evaluation

## 4.3.1

### Introduction

---

Managers of large inventories of infrastructure assets need a tool to effectively manage these assets. For bridge data, element level inspection has been successfully used as a basis for data collection, performance measurement, resource allocation, and management decision support. Although component condition rating and reporting, as described in the FHWA *Coding Guide*, provides a consistent method for evaluation and reporting, the data is not comprehensive enough to support bridge preservation performance-based decision support.

The Pontis CoRe (Commonly Recognized) Element Report (June 1993), which is the basis of the AASHTO CoRe Element Guide, was prepared by technical working group representatives from California, Colorado, Minnesota, Oregon, Virginia, Washington, and the Federal Highway Administration. The Pontis CoRE Report explains the reasoning behind the selection of bridge items that require inspection for a successful Bridge Management System. Pontis is ‘bridge’ in Latin.

In 2010, the AASHTO Bridge Element Inspection Manual was developed to address improvements to the existing CoRe Element Guide. This reference manual was prepared by representatives from California, Idaho, Michigan, Montana, New York and FHWA to further enhance bridge management.

Significant changes from the existing CoRe Element Guide:

- All elements have four defined condition states having general descriptions (good, fair poor, and severe).
- Wearing surfaces have been separated from decks/slabs and protective coatings.
- Elements have been categorized as National Bridge Elements (NBEs) or Bridge Management Elements (BMEs), with provisions for custom agency developed elements.
- Multiple distress paths provide the ability to incorporate all defects within the overall element assessment.
- Smart Flags (Defect Flags) have been revised to identify the predominant distress.

## 4.3.2

### Element Level Inspection Development

---

In developing a system for standardized data collection, the FHWA needed to look at the shortcomings of NBI (National Bridge Inventory) data. The problems with NBI data included:

- Each bridge is divided into only three major parts for condition assessment: deck, superstructure, substructure and culvert.
- The rating scale for these parts is 0-9 by severity of the deficiency, which does not indicate the extent of the deficiency.

- The component condition ratings are based on subjective interpretation by the inspectors.

A system was developed which included a standardized description of bridge elements at a greater level of detail. The FHWA created a task force to revise the standards and created a manual called "*Commonly Recognized (CoRe) Structural Elements*". The AASHTO Guide for CoRe Element Manual defined each element, the unit of measurement, definitions of a set of 3-5 standardized condition states, and feasible actions for each condition state. The CoRe Element Manual was accepted as an official AASHTO manual in May 1995. Some states developed their own CoRe Element Manual based on the AASHTO *Core Element Manual*. Approximately 40 states perform element level inspection.

In 2010, the limitations of the CoRe Element Manual were again addressed. These problems included:

- Inconsistent number of condition states and descriptions between element types
- Inconsistent condition state definitions between agencies
- Limited distress path language defined within the condition states

The National Bridge Element and Bridge Management Element system provides multiple distress paths for each defined condition state. This allows for deficiencies to be identified within each overall element assessment. The AASHTO *Guide Manual for Bridge Element Inspection* defines each element, description, unit of measurement or quantity calculation, set of four standardized condition states, feasibility actions, element commentary, and element definitions. The AASHTO *Guide Manual for Bridge Element Inspection, First Edition, 2011*, was first published as an official manual in February 2011.



### 4.3.3

#### **Element Level Rating Terminology**

The AASHTO *Guide Manual for Bridge Element Inspection, First Edition, 2011*. (see Figure 4.3.1) provides a description of structural elements that are commonly used in highway bridge construction and encountered on bridge safety inspections.

The following terms are used to describe bridge element-level inspection:

- National Bridge Elements (NBEs) represent the primary structural components of bridges necessary to determine the overall condition and safety of primary load carrying members. They provide a uniform basis for data collection.
- Bridge Management Elements (BMEs) represent a recommended set of condition assessment language that may be modified to suit the agency's needs. Examples of these elements include expansion joints and seals, approach slabs, wearing surfaces, protective coatings and smart flags.
- Agency developed elements are customized elements that can be sub-sets of defined NBEs, sub-sets of BMEs, or elements that are independent of the defined AASHTO elements. Agency developed elements are used in addition to the NBEs and BMEs.
- Condition states describe the severity of the deficiencies in AASHTO Bridge Elements. All elements have four defined condition states having general descriptions of good, fair, poor, and severe. Condition State 1 (good) and Condition State 4 (severe).
- Environments are used to classify the operating conditions and the deterioration of the structure, which does not change due to maintenance work or deficiencies. Depending on the agency, inspectors may or may not be responsible for determining the environment.
- Sub-elements or sub-sets are divisions of NBEs or BMEs that are created to provide flexibility to track variations in cost or performance characteristics.
- Smart Flags or Defect Flags are BMEs and used when a specific condition exists, which may be described in the National Bridge Element condition state definitions. They inherit the same units of measure as the NBE or BME to which they are assigned.
- Feasible actions, as provided in the AASHTO *Guide Manual for Bridge Element Inspection*, are general actions to address deficiencies. Feasible actions are often further defined by agencies for each condition state. Agency procedures vary and some inspectors create work recommendations for feasible actions. The inspector may not be required to record feasible actions.

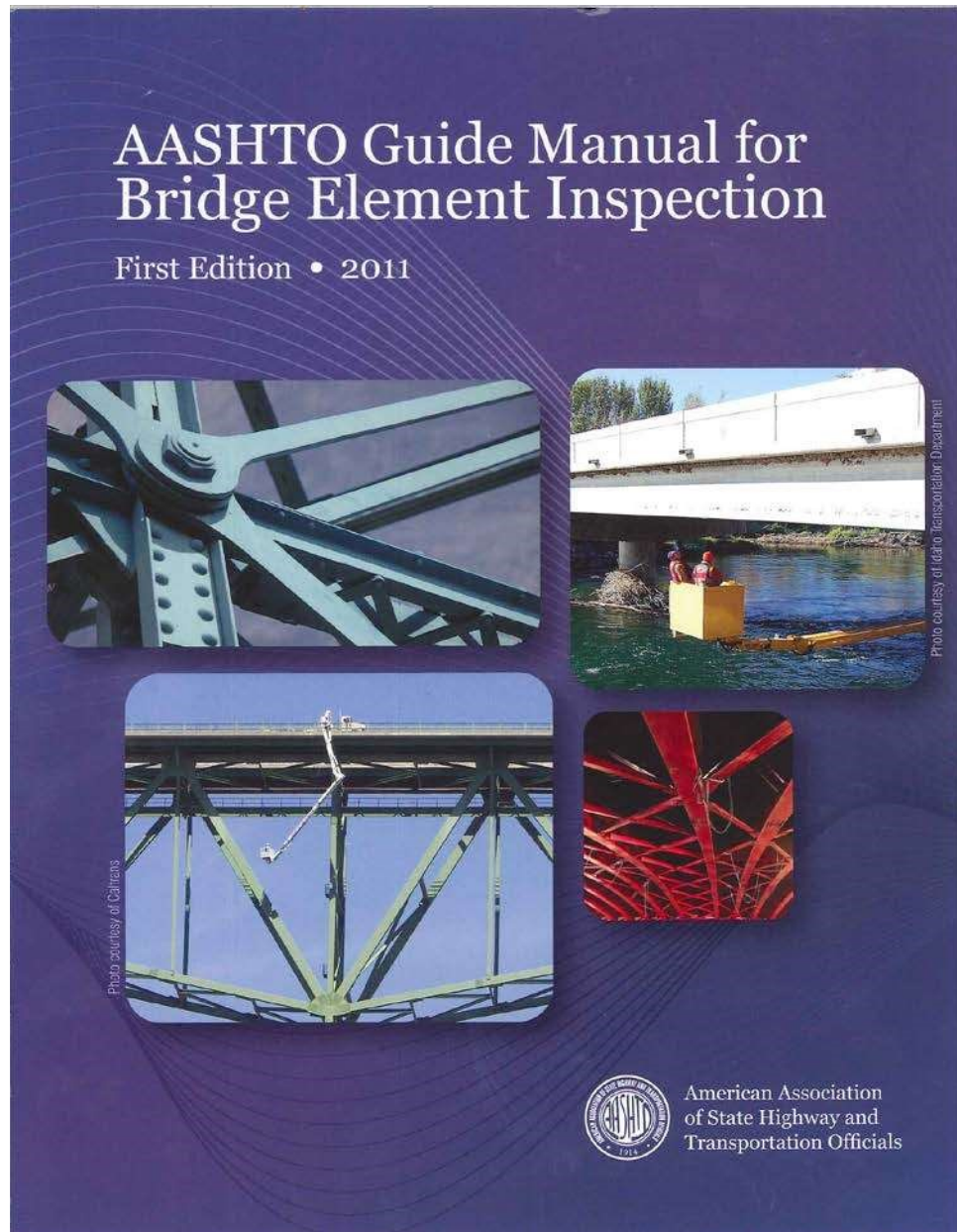


Figure 4.3.1 AASHTO Guide Manual for Bridge Element Inspection

#### 4.3.4

##### **Basic Requirements of National Bridge Elements**

In the development of National Bridge Elements, it was important that the specification must be generic. Different agencies have varying maintenance practices, funding mechanisms, policy concerns and terminology. However, the physical components of bridges and deterioration processes are not unique. Agencies must be able to customize the generic standard to satisfy their own purposes without sacrificing the benefits of a common standard. Any changes to elements could introduce incompatibility between agencies. For this reason, agencies cannot change the number of condition states and the intent of the condition state language.

To avoid this from happening, the bridge element guide manual provides the ability of an agency to add custom agency developed elements or modify recommended

Bridge Management Elements. It is possible for future National Bridge Elements or Bridge Management Elements to be added. These elements must be permanent, have clear distinction and be defined as concisely as possible. The guidelines for developing National Bridge Elements include:

- Each element must be a primary load carrying element
- Each element must have a unique functional role.
- Distinguish elements that have significantly different maintenance requirements.
- Distinguish elements that are measured in different ways for costing or inspection.
- Distinguish elements whose conditions are described in different ways.
- Each element must be significant from the standpoint of maintenance cost or functionality. This is why, for example, secondary members are omitted from the list of National Bridge Elements. The level of detail in data collection would be too large relative to the effect of these elements on decision making.
- Deterioration behavior and maintenance alternatives for the element must be sufficiently understood. This is why, for example, composite materials such as fiber reinforced polymer are excluded from the list of National Bridge Elements.
- If an element is more significant than other elements, its behavior or condition description is complex, the element may be subdivided into smaller elements. An example of this type of element would be a pin and hanger assembly.
- A formal definition of each element must be developed to clarify thinking.

One primary use of definitions is to establish a useful inventory. In the field, each element must be clearly identified, measured and counted economically. It is also important to describe element attributes, such as size, material, condition and serviceability, quantitatively. The commonality aspect of National Bridge Elements depends on having definitions that are widely understood and are stable over time. One major factor contributing to definitions being widely understood is NHI's bridge inspection related training courses.

### **4.3.5**

---

## **Bridge Element Identification**

### **National Bridge Elements**

AASHTO National Bridge Elements describe primary load carrying members, including:

- Girders
- Trusses
- Arches
- Cables
- Floorbeams
- Stringers

- Abutments
- Piers
- Pins and Hangers
- Culverts
- Bearings
- Railings
- Decks
- Slabs
- Gusset Plates
- Column/Piles
- Caps

See Figures 4.3.2 - 4.3.4 for a list of decks/slabs, superstructure, and substructure AASHTO National Bridge Elements.

| Element                                    | Units  | Element Number (Decks) | Element Number (Slab) | Other |
|--|--------|------------------------|-----------------------|-------|
| Reinforced Concrete Deck/Slab              | AREA   | 12                     | 38                    |       |
| Prestressed/Reinforced Concrete Top Flange | AREA   | 15                     |                       |       |
| Steel Deck - Open Grid                     | AREA   | 28                     |                       |       |
| Steel Deck - Concrete Filled Grid          | AREA   | 29                     |                       |       |
| Steel Deck - Corrugated/Orthotropic/Etc.   | AREA   | 30                     |                       |       |
| Timber Deck/Slab                           | AREA   | 31                     | 54                    |       |
| Bridge Rail                                |        | Other                  |                       |       |
| Metal Bridge Railing                       | LENGTH |                        |                       | 330   |
| Reinforced Concrete Bridge Railing         | LENGTH |                        |                       | 331   |
| Timber Bridge Railing                      | LENGTH |                        |                       | 332   |
| Other Bridge Railing                       | LENGTH |                        |                       | 333   |
| Masonry Bridge Railing                     | LENGTH |                        |                       | 334   |

AREA = square feet (square meter)

LENGTH= feet (meters)

**Figure 4.3.2** Decks/Slabs National Bridge Elements in the AASHTO *Guide Manual for Bridge Element Inspection*

| Element                            | Units  | Steel    | Prestressed Concrete | Reinforced Concrete | Timber | Masonry | Other |
|------------------------------------|--------|----------|----------------------|---------------------|--------|---------|-------|
| Girder/Beam                        | LENGTH | 107      | 109                  | 110                 | 111    |         |       |
| Closed Web/Box Girder              | LENGTH | 102      | 104                  | 105                 |        |         |       |
| Stringer                           | LENGTH | 113      | 115                  | 116                 | 117    |         |       |
| Truss                              | LENGTH | 120      |                      |                     | 135    |         |       |
| Arch                               | LENGTH | 141      | 143                  | 144                 | 146    | 145     |       |
| Floor Beam                         | LENGTH | 152      | 154                  | 155                 | 156    |         |       |
| Cable                              | EA     | 147, 148 |                      |                     |        |         |       |
| Gusset Plate                       | EA     | 162      |                      |                     |        |         |       |
| Pin and/or Pin and Hanger Assembly | EA     | 161      |                      |                     |        |         |       |

LENGTH= feet (meters)  
 EA = Each

**Figure 4.3.3** Superstructure National Bridge Elements in the AASHTO *Guide Manual for Bridge Element Inspection*

| Element                                  | Units  | Steel | Prestressed Concrete | Reinforced Concrete | Timber | Masonry | Other |
|--|--------|-------|----------------------|---------------------|--------|---------|-------|
| Column/Pile Extension                    | EA     | 202   | 204                  | 205                 | 206    |         |       |
| Column Tower (Trestle)                   | EA     | 207   |                      |                     | 208    |         |       |
| Submerged Pile                           | EA     | 225   | 226                  | 227                 | 228    |         |       |
| Pier Wall                                | LENGTH |       |                      | 210                 | 212    | 213     | 211   |
| Abutment                                 | LENGTH | 219   |                      | 215                 | 216    | 217     | 218   |
| Pier Cap                                 | LENGTH | 231   | 233                  | 234                 | 235    |         |       |
| Pile Cap/Footing                         | EA     |       |                      | 220                 |        |         |       |
| Culvert                                  | LENGTH | 240   |                      | 241                 | 242    | 244     | 243   |
| <b>Bearings</b>                          |        |       |                      |                     |        |         |       |
| Elastomeric Bearing                      | EA     |       |                      |                     |        |         | 310   |
| Moveable Bearing (roller, sliding, etc.) | EA     |       |                      |                     |        |         | 311   |
| Enclosed/Concealed Bearing               | EA     |       |                      |                     |        |         | 312   |
| Fixed Bearing                            | EA     |       |                      |                     |        |         | 313   |
| Pot Bearing                              | EA     |       |                      |                     |        |         | 314   |
| Disk Bearing                             | EA     |       |                      |                     |        |         | 315   |

LENGTH= feet (meters)  
 EA = Each

**Figure 4.3.4** Substructure National Bridge Elements in the AASHTO *Guide Manual for Bridge Element Inspection*

### Bridge Management Elements

AASHTO Bridge Management Elements represent a recommended condition assessment language that can be modified to suit the agency's needs. The following types of elements are defined as Bridge Management Elements:

- Joints
- Approach Slabs
- Wearing Surfaces
- Protective Systems
- Smart Flags (Defect Flags)



See Figures 4.3.5 - 4.3.6 for a list of decks/slabs and wearing surfaces and protection systems AASHTO Bridge Management Elements.

| Element                           | Units  | Element Number |
|-----------------------------------|--------|----------------|
| <b>Joints</b>                     |        |                |
| Strip Seal Expansion Joint        | LENGTH | 300            |
| Pourable Joint Seal               | LENGTH | 301            |
| Compression Joint Seal            | LENGTH | 302            |
| Assembly Joint/Seal (modular)     | LENGTH | 303            |
| Open Expansion Joint              | LENGTH | 304            |
| Assembly Joint w/o Seal           | LENGTH | 305            |
| <b>Approach Slabs</b>             |        |                |
| P/S Concrete Approach Slab        | AREA   | 320            |
| Reinforced Concrete Approach Slab | AREA   | 321            |

AREA = square feet (square meter)

LENGTH= feet (meters)

EA = Each

**Figure 4.3.5** Decks/Slabs Bridge Management Elements in the AASHTO *Guide Manual for Bridge Element Inspection*

| Element                      | Units | Element Number |
|------------------------------|-------|----------------|
| <b>Protective Systems</b>    |       |                |
| Wearing Surfaces             | AREA  | 510            |
| Steel Protective Coating     | AREA  | 515            |
| Deck/Slab Protection Systems | AREA  | 520            |
| Concrete Protective Coating  | AREA  | 521            |

AREA = square feet (square meter)

**Figure 4.3.6** Wearing Surfaces and Protective Systems in the AASHTO *Guide Manual for Bridge Element Inspection*

## Defect Flags

Defect Flags are part of the Bridge Management Elements and are used to identify the predominant defect for that condition state. The severity of the deficiency is captured by coding the appropriate Defect Flag condition state. The NBI translator uses AASHTO element-level data that includes defect flag data to determine NBI component condition ratings.

Defect Flags inherit the units of the parent NBE or BME.

- |   |   |
|---|---|
| Steel Cracking/Fatigue:                 | This flag shall be used with steel elements to identify the predominant defect in a given condition state that is not corrosion.  |
| Pack Rust:                              | This flag shall be used in conjunction with steel elements connection defects (including shapes in contact in built-up members) of steel bridges that are already showing signs of rust packing between plates.   |
| Concrete Cracking:                      | This flag shall be used with concrete elements to identify the predominate defect in a given condition state that is not spalling or delaminations.   |
| Concrete Efflorescence:                 | This flag shall be used with concrete elements to identify the predominate defect in a given condition state that is not spalling or delaminations.   |
| Settlement:                             | This flag shall be used with all substructure and culvert elements to identify the predominate defect in a given condition state that is not material deterioration. The use of the flag is to identify the severity of the settlement.                                   |
| Scour:                                  | This flag shall be used with all substructure and culvert elements to identify the predominate defect in a given condition state that is not material deterioration. The use of the flag is to identify the severity of the scour.  |
| Superstructure Traffic Impact:          | This flag shall identify all traffic collisions with the superstructure. Application of the flag is in relation to the impact on the structures capacity to carry load.   |
| Steel Section Loss:                     | This flag shall be used with steel elements to identify the predominate defect in a given condition state that is not corrosion. Setting this flag will identify the severity of section loss.  |
| Steel Out-of-plane Compression Members: | This flag shall be used with steel truss or arch elements. The use of the flag shall denote any member that is not in plane with the panel (buckling). It shall be used to identify the predominate defect in a given condition state that is not material deterioration. |
| Deck Traffic Impact:                    | This flag shall identify all traffic collisions with the deck. Application of the flag is in relation to the impact on the structures capacity to carry load.   |

|                              |   |
|------------------------------|---|
| Substructure Traffic Impact: | This flag shall identify all traffic collisions with the substructure. Application of the flag is in relation to the impact on the structures capacity to carry load.   |
| Barrel Distortion:           | This flag is to identify the severity of the culvert barrel distortion. Its use shall be with culverts only. This flag shall describe predominate culvert deterioration that is not attributed to material deterioration. |

### **Agency Developed Elements**

Agencies may develop sub-elements that use the same condition state definitions as their associated NBE or BME elements. This allows for more detailed element descriptions. They are a subset of the NBE or BME and allow a more detailed classification. They are often created to distinguish a different size, location or exposure.

- Fascia girders and interior girders can be examples of Sub-Elements.
- The ends of girders can be examples of Sub-Elements.

Agency developed elements fall into three main categories: subsets of NBEs, BMEs, or elements that are independent of defined elements. Agency Developed Element guidelines are listed below:

#### **Agency Defined Subsets of NBEs**

For agency defined sub-sets of National Bridge Elements, the agency must be able to combine the sub-elements back together to form the original NBE element for NBI submission with the original condition state and element definition language.

#### **Agency Defined Subsets of BMEs**

For agency defined sub-sets of Bridge Management Elements, the agency is not required to combine the elements to form the original Bridge Management Elements since BMEs are not required for NBI submission. However, custom elements of this type must retain the original number of condition states using a good, fair, poor, severe description.

#### **Independent Agency Developed Elements**

For Agency Defined Elements that are not sub-sets of National Bridge Elements or Bridge Management Elements, the only requirement is the standardized number of condition states (four). These elements may include inventory items or specific aspects of the structure. Independent Agency Defined Elements may or may not include feasible actions, deficiency, or official condition state language.

Examples of potential independent agency developed elements include approach guardrail, approach guardrail ends, seismic retrofit components, tunnels, condition of drainage components or lighting fixtures, or ancillary items such as overhead signing structures.

### 4.3.6

#### **Condition States**

The scale of good-fair-poor-severe is not acceptable because these terms do not have precise definitions that can be observed in the field. It was decided to measure bridge condition on a single scale that reflects common processes for deterioration and the effect on serviceability. The general pattern for a Bridge Element having four condition status is as follows:

1. Good – No deterioration to minor deterioration
2. Fair – Minor to Moderate deterioration
3. Poor – Moderate to Severe deterioration
4. Severe – Beyond the limits established in condition state 3 and/or warrants a structural review to determine strength or serviceability of the element or bridge

Each of these levels of deterioration is called a condition state. The condition state methodology provides two types of information about a bridge element's deterioration:

- Severity – characterized by precise definition of each condition state
- Extent – the distribution of the total element quantity among condition states

The severity is important for selection of a feasible and cost effective preservation treatment, and extent is important for cost estimation.

Assignment of quantities to condition states is determined from element definitions and element commentary for National Bridge Elements. Condition state definitions are guidelines to the bridge inspector for categorization of the severity of the deficiency. Element commentary represents additional considerations for the inspector during the collection of data. From this information, the inspector can complete the element level evaluation. Additionally, element level Smart Flags (Defect Flags) are used to describe a condition which is not included in the National Bridge Element or Bridge Management Element condition state language.

### 4.3.7

#### **Feasible Actions**

Feasible actions are those that an agency may take to remove the defect. They represent a set of responses that may be taken for an element based upon quantities within a given condition state. They also represent general guidance on agency preservation strategies and can be customized by each agency for each element and condition state.

A summary of feasible actions and associated condition states is given below. Depending on the element, some feasible actions/conditions states may not be available. Other feasible actions, such as "Do Nothing", are available for all elements and condition states. "Do Nothing" can be used for all the elements in condition states since the possibility of nothing that needs to be done due to the condition of the element being good or to be used if the condition of the bridge is

so severe, the bridge is closed and or there is a feasible action already taking place.

| Feasible Action                                   | Condition State |   |   |   |
|---|-----------------|---|---|---|
|   | 1               | 2 | 3 | 4 |
| Do Nothing  | •               | • | • | • |
| Protect   | •               | • | • | • |
| Preserve (for other culverts and other railings ) | •               | • |   |   |
| Repair  |                 | • | • | • |
| Rehab   |                 |   | • | • |
| Reset (for bearings only)                         |                 |   | • | • |
| Replace   |                 |   | • | • |

### 4.3.8

#### Environments

Element can exist in one of four environments, which describe different weather or operating conditions. The environments are important for deterioration models and prediction of future conditions. The four environments are defined in general terms as follows:

1. Benign – No environmental or operational conditions affecting deterioration
2. Low – Environmental or operational conditions create no adverse impacts, or are mitigated by past non-maintenance actions or highly effective protective systems
3. Moderate – Typical level of environmental or operational conditions influence on deterioration
4. Severe – Environmental or operational conditions factors contribute to more rapid deterioration. Protective systems are not in place or are ineffective

Environment policies are used for element level inspection and set by individual state agencies.

### 4.3.9

#### The Role of Element Level Data in Bridge Management Systems

An immediate application of Bridge Elements is the collection and analysis of performance data. It is essential that original data collection be as objective and repeatable as possible. This raw, objective data must be stored so that the analysis may be updated or improved at a later time. Bridge Elements must be usable to support management decision making. The large volume of raw data collected must be transformed into useful information. For this reason, the development of bridge Bridge Elements was heavily influenced by the parallel development of Pontis software and previous CoRe elements.



Condition state data provides quantitative data about the physical condition and performance of bridge elements. This data is also, the effects of treatment actions can be tracked over time. Element level data is an essential part of the following BMS functions. Element level inspections can track the effectiveness of action over time by showing the various condition states and how they may change over time after the bridge element is either repaired, replaced, or nothing would be done. Potential applications for agencies includes:

- Identification of bridge needs (replacement and preservation)
- Development and testing of new maintenance techniques
- Treatment selection policies
- Project priority setting and programming
- Budgeting
- Funding allocation
- Long-range planning

This page intentionally left blank.

# Table of Contents

## Chapter 4 Bridge Inspection Reporting

---

|       |  |        |
|-------|--|--------|
| 4.4   | Record Keeping and Documentation .....         | 4.4.1  |
| 4.4.1 | Introduction.....                              | 4.4.1  |
| 4.4.2 | Bridge Records.....                            | 4.4.1  |
|       | Plans .....                                    | 4.4.2  |
|       | Specifications .....                           | 4.4.2  |
|       | Correspondence.....                            | 4.4.2  |
|       | Photographs .....                              | 4.4.2  |
|       | Photo Log.....                                 | 4.4.2  |
|       | Materials and Tests.....                       | 4.4.3  |
|       | Maintenance and Repair History .....           | 4.4.3  |
|       | Coating History .....                          | 4.4.3  |
|       | Accident Records.....                          | 4.4.3  |
|       | Posting.....                                   | 4.4.4  |
|       | Permit Loads.....                              | 4.4.4  |
|       | Flood and Scour Data .....                     | 4.4.5  |
|       | Traffic Data .....                             | 4.4.5  |
|       | Inspection History .....                       | 4.4.5  |
|       | Inspection Requirements .....                  | 4.4.6  |
|       | Structure Inventory and Appraisal Sheets ..... | 4.4.7  |
|       | Inventories and Inspections .....              | 4.4.7  |
|       | Bridge Inspection Forms.....                   | 4.4.7  |
|       | Rating Records .....                           | 4.4.9  |
| 4.4.3 | Methods of Inspection Documentation .....      | 4.4.10 |
|       | Traditional .....                              | 4.4.10 |
|       | Electronic Data Collection .....               | 4.4.10 |
| 4.4.4 | Inspection Report Documentation .....          | 4.4.11 |
|       | Element Identification .....                   | 4.4.11 |
|       | Structure Site Orientation.....                | 4.4.12 |
|       | Bridge Member Orientation .....                | 4.4.12 |
|       | Element Dimensions.....                        | 4.4.14 |
|       | Inspection Notes and Sketches .....            | 4.4.16 |
|       | Deficiency Identification.....                 | 4.4.18 |
|       | Deficiency Qualification .....                 | 4.4.19 |
|       | Deficiency Quantification .....                | 4.4.19 |
|       | Deficiency Location .....                      | 4.4.19 |
|       | Summary of Findings .....                      | 4.4.22 |

### Abbreviations for Field Inspection Notes

|                                    |                                   |
|------------------------------------|-----------------------------------|
| Abut. = Abutment                   | Hvy. = Heavy                      |
| Adj. = Adjacent                    | Int. = Interior                   |
| B. = Bent                          | Lac. = Lacing                     |
| Btw. = Between                     | Lat. = Lateral                    |
| Bot. = Bottom                      | Lat. Br. = Lateral Brace          |
| B.S. = Both Sides                  | Lgth. = Length                    |
| [ = Channel (Steel Shape)          | Low. = Lower                      |
| cm = Centimeter                    | Lt. = Light                       |
| Col. = Column                      | M = Meters                        |
| Conc. = Concrete                   | Med. = Medium                     |
| Cond. = Condition                  | Mid. = Middle                     |
| Conn. = Connection                 | N = North                         |
| Cr. = Crack                        | No Vis. Def. = No Visible Defects |
| Delam. = Delamination, Delaminated | N.S. = Near Side                  |
| Deter. = Deterioration             | P = Pier                          |
| Diag. = Diagonal                   | Pl. = Plate                       |
| Diam. = Diameter                   | S = South                         |
| Diaph. = Diaphragm                 | S.I.P. = Stay-in-Place Forms      |
| D.S. = Downstream                  | SF = Square Feet                  |
| E = East                           | Stiff. = Stiffener                |
| Eff. = Efflorescence               | Str. = Stringer                   |
| Elev. = Elevation                  | T. Welds = Tack Welds             |
| Exp. = Expansion                   | Typ. = Typical                    |
| F.B. = Floorbeam                   | U = Upper                         |
| F.L. = Full Length                 | U.S. = Upstream                   |
| Flg. = Flange                      | Vert. = Vertical                  |
| F.S. = Far Side                    | Vis. = Visible                    |
| Ft. = Feet                         | Vis. S. = Visible Signs           |
| Gus. = Gusset                      | W = West                          |
| H.L. = Hairline                    | W = Wide Flange (Steel Shape)     |
| Horz. = Horizontal                 | L = Angle (Steel Shape)           |

# Topic 4.4 Record Keeping and Documentation

## 4.4.1

### Introduction

Bridge owners maintain a complete, accurate, and current record of each bridge under their jurisdiction. Such information relating directly to the inspection, design, performance and maintenance of the bridge is vital to the effective management of a population of bridges. Additionally, this information provides a record that may be important for repair, rehabilitation, or replacement of their assets.

The first section in this topic covers the critical components of the bridge record, while the remaining sections provide the inspector with guidance on how to thoroughly organize inspection data and produce an accurate and effective inspection report.

## 4.4.2

### Bridge Records

Bridge records, or files, are used to maintain detailed, cumulative and up-to-date information on each structure. A thorough study of the available historical information can be extremely valuable in identifying possible critical areas of structural or hydraulic components and features.

The contents of any particular bridge file may vary depending upon the size and age of the structure, the functional classification of the road carried by the structure, and the informational needs of the agencies responsible for inspection and maintenance. The bridge file is not only a resource to the bridge owner, but also a resource to the inspector. The inspector will gain valuable insight into the bridge by being familiarized with it prior to the inspection. It is recommended that the following types of information be assembled when possible.

According to the *AASHTO Manual for Bridge Evaluation*, the bridge record includes the following information:

- Plans, including construction plans, shop and working drawings, and “as-built” drawings
- Specifications
- Correspondence
- Photographs
- Materials and tests, including material certification, material test data, and load test data
- Maintenance and repair history
- Coating history
- Accident records
- Posting
- Permit loads
- Flood and scour data
- Traffic data
- Inspection history
- Inspection requirements



- Structure Inventory and Appraisal sheets
- Inventories and inspections
- Rating records

**Plans**

Construction, “as-built,” or shop and working plans are included in a bridge record. If plans are not available, determine the following types of construction information: date built; type of structure, including size, shape, and material; design capacity; and design service life. Hydraulic data is also assembled where available, including structure profile gradeline, elevation of inverts or footings, stream channel and water surface during normal and high flows, design storm frequency, drainage area, design discharge, date of design policy, flow conditions, limits of flood plain, type of energy dissipaters (if present), cut-off wall depth, channel alignment, and channel protection.

**Specifications**

The bridge record includes a complete copy of the technical specifications used to design and build the bridge. When a general specification was used, only the special provisions are included in the file. The edition and date of the general specifications are noted in the bridge record.

**Correspondence**

The bridge record includes any applicable letters, memorandums, and notices of project completion, construction diaries, telephone logs, and any other information directly concerning the bridge in chronological order.

**Photographs**

Photographs are used to supplement the inspection notes and sketches. A minimum of two photographs are included in the bridge record: a topside view of the bridge roadway and at least one elevation view of the bridge. Photographs showing major deficiencies or other features, such as utility attachments or channel alignment, also are included. Photographs that show load posting signs are also provided, if applicable.

**Photo Log**

Keep a photo log during the inspection. The photo log includes the date, photo number, and description of each photograph. It is best to be very specific when describing the photos (see Figure 4.4.1). Descriptions include both the location of the member and a brief description of any deficiencies.

**PHOTO LOG FORM**

INSPECTORS GRL (WB) PHOTO LOG NO. \_\_\_\_\_  
 BRIDGE NO. MP-056-0064-B00293 DATE: 7.9.11 (Photos 1-11)  
 BRIDGE NAME 7th Street to 13th Street Unit 7.10.11

| PHOTO # | LOCATION                        | DESCRIPTION   |
|---------|---------------------------------|---|
| 1       | Pier 46WB<br>from parking level | General View<br>Sta Ahd<br>at end of Ramp (left) beg. at<br>Pier 47WB   |
| 2       | Pier 49WB                       | crack at end weld<br>at Girder Conn (S9-Span 48WB)  |
| 3-7     | Pier 49W<br>Span 49W            | Gen View of end weld crack<br>w/ close-ups  |
| 8       | North side<br>Pier 50WB         | Gen View of Fascia Girder (S19)<br>w/ full length long stiffeners   |
| 9       | Pier 55WB                       | top strip seal over cross<br>girder and pin & hanger assembly   |
| 10      | Pier 55WB<br>(north side)       | Top View of Deck<br>Looking Bk Stations   |
| 11      | Pier 55WB                       | Pin & Hanger Assembly<br>w/ Bot support<br>(Looking North)  |
| 12      | Span 48WB<br>Girder S5          | 2nd Diaph (Cross Bracing) Top<br>Conn & end weld cracking<br>and toe weld cracking on Girder web<br>in Flg (Previously reported - on change)<br>opposite end of how similar condition |

**Figure 4.4.1** Sample Photo Log

**Materials and Tests**

Certificates for the type, grade, and quality of materials used in construction of the bridge are included in the bridge record. Examples include steel mill certificates, concrete delivery slips, and any other manufacturers' certificates. The certificates are retained in accordance with bridge owner policy and statute of limitations.

Reports for any non-destructive or laboratory testing either during or after construction are included. If any field load testing is performed, provide the reports in the bridge record.

**Maintenance and Repair History**

Information about repairs and rehabilitation activities are included in the bridge record. This chronological record includes details such as the date, project description, contractor, cost, contract number and any other related data. The types and amount of repairs performed at a bridge or culvert site can be extremely useful. For example, frequent roadway patching due to recurring settlement over a culvert or approach roadway for a bridge may indicate serious problems that are not readily apparent through a visual inspection of the structure.

**Coating History**

This information in the bridge record documents the surface protective coatings used, including surface preparation, application method, dry film paint thickness, types of paint, concrete and timber sealants, and other protective membranes.

**Accident Records**

Include details of accidents or damage to the bridge in the bridge record (see Figure 4.4.2). This information includes the date of the occurrence, description of the accident, member damage and repairs, and any investigative reports.



**Figure 4.4.2** Accident Involving Construction Equipment and a Bridge

### Posting

Each bridge record includes load capacity calculations and any required posting arising from the load ratings. The summary of posting actions includes the date of posting and a description of the signing used (see Figure 4.4.3).



**Figure 4.4.3** Posted Bridge

### Permit Loads

A record of the most significant single-trip permit loads using the bridge are included in the bridge record. This information is to include any applicable documentation and calculations.

**Flood and Scour Data**

A chronological history of major flooding events are included for bridges over water (see Figure 4.4.4). This history includes the high water marks at the bridge site, scour evaluation, scour history, and any plan of action.



**Figure 4.4.4** Flood Event

**Traffic Data**

When available, the bridge record contains a history of the variations in Average Daily Traffic (ADT) and Average Daily Truck Traffic (ADTT) including the frequency and types of vehicles using the bridge. ADT and ADTT are important factors in determining fatigue life and are monitored for each bridge and each traffic lane on the bridge. If available, weights of the vehicles using the bridge are also included in the bridge record.

**Inspection History**

Reports from previous inspections can be particularly useful in identifying specific locations that require special attention during an inspection. Information from earlier inspections can be compared against current conditions to estimate rates of deterioration and to help judge the seriousness of the problems detected and the anticipated remaining life of the structure.

This chronological record of inspections performed on the bridge includes the date and type of inspection. The initial inspection report is included in the bridge record. Earthquake data, fracture critical member information, deck evaluations, and corrosion studies are also included when available.

**Inspection Requirements** Inspections are planned and prepared for by taking into account needed access, inspection equipment, structural details, inspection methods, and the required qualifications of inspection personnel. In addition, the National Bridge Inspection Standards require that written inspection procedures for specific types of more complex inspections (fracture critical, underwater, and complex bridges) be developed to address those items that need to be communicated to an inspection team leader to ensure a successful bridge inspection. Section 4 of the AASHTO *MBE* has general considerations regarding inspection plans. An owner may have general overall inspection procedures in their bridge inspection manual that address common aspects of these more complex inspections, however, each bridge will have written inspection procedures specific to each bridge which address items unique to each bridge. The following items are to be addressed for each of these types of bridge inspections, either in the bridge specific inspection procedures, or by referring to general inspection procedures (typically in an agency's bridge inspection manual):

- Identify each of the critical members to be inspected (fracture critical elements, past repairs, underwater elements, complex features, fatigue prone details, scour countermeasures, etc.) on plan sheets, drawings or sketches
- Identify special access needs or equipment necessary to gain the access required to inspect the features (under bridge inspection trucks, man lifts, traveler system, climbing, etc.)
- Describe the inspection method(s) and frequency to be used for the elements. For example, “Visually inspect all identified FCMs at arm’s length for cracks, deterioration, missing bolts, loose connections, broken welds... using PT to verify the existence of suspected cracks.”
- Address required proximity to details, such as “arm’s length”
- Identify special qualifications required of inspection personnel by the program manager, if any (successfully passed fracture critical course, certified electrician for movable bridge electrical components, qualified bridge inspection diver, etc., may be possible qualifications)

Other items that may be addressed depending on each unique situation might include:

- Special contacting procedures prior to inspection (Coast Guard, security, operations personnel, etc.)
- Safety concerns (snakes, bats, etc.)
- Best time of year to inspect the bridge (lake draw down, canal dry time, snow, ice, bird nesting seasons, etc.)
- Anything else the program manager wants the inspection team leader to be aware of in preparation for the inspection

Any special requirements to ensure inspector and public safety, including a traffic management plan, are also included.



**Structure Inventory and Appraisal Sheets** A chronological record of SI&A forms used by the bridge owner is included in the bridge record. Refer to Topic 4.1 for a complete description of SI&A sample form.

**Inventories and Inspections** Inspection reports are included as part of the bridge record. This information includes the results of all inventories and bridge inspections and can include construction or repair activities.

### **Bridge Inspection Forms**

Many bridge owners have standard inspection forms. These forms are used for each bridge in their system and give the inspector a checklist of items that are to be reviewed. Another benefit of standardized forms is that it organizes bridge reports into a consistent format (see Figures 4.4.5 and 4.4.24 that are located at the end of this topic).





**Rating Records**

A complete record of the determination of the bridge's load-carrying capacity is included in the bridge record (see Figure 4.4.6). This information will include the design load to indicate the live load the bridge was designed for, the analysis methods used to determine the inventory and operating ratings, and the inventory and operating ratings for the bridge. The capacity calculations will be signed and dated by the individual who determined them, together with any assumptions used.

| Nebraska Department of Roads - Bridge Division<br>Load Rating Summary Sheet  |  |                    |          |
|--|--|--------------------|----------|
| State Bridge Number  | C008500335   | Analyst            |          |
| County Bridge Number   | T4N R4W SEC 8 L  | Analysis Date      | 3/8/2007 |
| Structure Type   | Concrete continuous -- Slab  | Year Built         | 1998     |
| Highway System   | Not on National Highway System   | Year Reconstructed |          |
|  |  | Design Load        | H520     |
| <b>NBI Rating Factor Summary (HS or HL93):</b>   |  |                    |          |
| Inventory Capacity   | 1.11   | Operating Capacity | 1.85     |
| <b>Legal Truck Summary:</b>  |  |                    |          |
| Type 3 (Tons)  | 61   | Type 3S2 (Tons)    | 67       |
|  |  | Type 3-3 (Tons)    | 101      |
| <b>Recommended Posting Summary:</b>  |  |                    |          |
| Type 3 (Tons/NA)   |  | Type 3S2 (Tons/NA) |          |
|  |  | Type 3-3 (Tons/NA) |          |
| Posting is required for capacities less than 25T, 37T, and 43T respectively. Gross Posting should be avoided.  |  |                    |          |
| <b>Permit Load Summary:</b>  |  |                    |          |
| Type 3 (Tons)  | 79   | Type 3S2 (Tons)    | 87       |
|  |  | Type 3-3 (Tons)    | 132      |
| For permitting purposes only, capacity based on a single lane distribution factor with no impact. No other vehicles are to be allowed on the bridge, crawl speeds less than 5 mph, and no gear shifting or braking, are to be strictly observed.   |  |                    |          |
| Rating Method: <input type="checkbox"/> ASR <input checked="" type="checkbox"/> LFR <input type="checkbox"/> LRFR <input type="checkbox"/> Other   |  |                    |          |
| Rating Information Provided: <input checked="" type="checkbox"/> Plans <input type="checkbox"/> Field Measurements <input type="checkbox"/> Testing <input type="checkbox"/> No Information Exists   |  |                    |          |
| Depth & Type of Overlay: 1 in. <input checked="" type="checkbox"/> Concrete <input type="checkbox"/> Gravel <input type="checkbox"/> Asphalt <input type="checkbox"/> Other  |  |                    |          |
| <b>Condition Rating:</b>   |  |                    |          |
| Deck:  | 9  | Superstructure:    | 9        |
|  |  | Substructure:      | 9        |
|  |  | Pile:              | 9        |
|  |  | Scour:             | 8        |
| <b>Load Rating Evaluation Summary:</b> I = Investigated C = Controls (HS or HL93)  |  |                    |          |
| <input checked="" type="checkbox"/> <input checked="" type="checkbox"/> + M of Interior Girder / Beam  | <input type="checkbox"/> <input type="checkbox"/> Truss Members                          |                    |          |
| <input checked="" type="checkbox"/> <input type="checkbox"/> + M of Exterior Girder / Beam   | <input type="checkbox"/> <input type="checkbox"/> Floor Beams                            |                    |          |
| <input checked="" type="checkbox"/> <input type="checkbox"/> - M of Interior Girder / Beam   | <input type="checkbox"/> <input type="checkbox"/> Stringers                              |                    |          |
| <input checked="" type="checkbox"/> <input type="checkbox"/> - M of Exterior Girder / Beam   | <input type="checkbox"/> <input type="checkbox"/> Pins                                   |                    |          |
| <input type="checkbox"/> <input type="checkbox"/> Shear At/Near Reactions  | <input type="checkbox"/> <input type="checkbox"/> Hangers                                |                    |          |
| <input type="checkbox"/> <input type="checkbox"/> Deck Overhang  | <input type="checkbox"/> <input type="checkbox"/> Substructure Elements                  |                    |          |
| <input type="checkbox"/> <input type="checkbox"/> Deck Between Girders   | <input type="checkbox"/> <input type="checkbox"/> Sidewalks/Medians w/o Traffic Barriers |                    |          |
| <input type="checkbox"/> <input type="checkbox"/> Fatigue Prone Details  | <input type="checkbox"/> <input type="checkbox"/> Scour                                  |                    |          |
| <b>Additional Comments</b> (Include any section loss, location of section loss, assumptions, and hand calculation references used in this analysis)  |  |                    |          |
|  |  |                    |          |
| (Seal & Date)  |  |                    |          |
| The recommended Rating and Posting for this structure are based on a theoretical analysis of the structural elements involved, and on a limited amount of information concerning their condition. These weight limits are intended only as a general guideline and may be varied accordingly by the officials responsible for this structure after an investigation of the structural condition, reaction to vehicular loads and any other items where judgement is required to establish a proper weight limit. |  |                    |          |
| DR Form 464, Jan 07  |  |                    |          |

**Figure 4.4.6** Example Load Rating Summary Sheet

Post or restrict the bridge in accordance with the AASHTO *Manual for Bridge Evaluation* or in accordance with State law, when the maximum unrestricted legal loads or State routine permit loads exceed that allowed under the operating rating or equivalent rating factor.

### 4.4.3

## Methods of Inspection Documentation

### Traditional

Note all signs of distress and deterioration with sufficient precision so that future inspectors can readily make a comparison of conditions. The most commonly used method for record keeping is pencil and paper. The inspector writes findings on forms, sketches, and notebooks (see Figure 4.4.7). This method is extremely flexible in that the inspector can draw whatever configurations are necessary to best describe and document deficiencies.



**Figure 4.4.7** Inspector Taking Notes

### Electronic Data Collection

Another method of record keeping is electronic data collection (see Figure 4.4.8). This technology provides a significant advantage in a number of areas. With all the bridge data available at the site, the inspector can retrieve and edit previous records and save them as current inspection data. This not only saves time but eliminates the need for reentering data. Also, it eliminates errors that can occur when transferring the inspector's field notes to the computer back at the office. Electronic data collection provides a logical and systematic sequence of inspection, ensuring that no bridge elements are overlooked. It also allows the inspector to compare the current deficiencies with previous reports and note if any deterioration has gotten worse.



**Figure 4.4.8** Electronic Data Collection

#### 4.4.4

### **Inspection Report Documentation**

While the inspection of small bridges usually only requires the use of the standard inspection form, the inspection of large or complex bridges requires the use of an inspection file, in addition to any standard inspection forms. The inspection file contains:

- Standard nomenclature and abbreviations for the elements of members and the components made up of these members
- Sketches of elements or members showing typical and deteriorated conditions (some of these can be pre-made to allow more expediency during the inspection)
- A standard notation system for indicating the condition of the elements or members
- A log or index for photographs
- Brief narrative descriptions of general and component conditions

When the above, detailed file format is selected for recording bridge inspection results, the information is to be recorded systematically. However, many bridge owners differ significantly in their required format. Most of the above information, if not provided on the inspection report, is available in the bridge record.

### **Element Identification**

Identify the elements by the type of material, construction method, and the function that each element or member performs.

Some examples of elements or members and their abbreviations:

- Multi-beam (B1 – B6)
- Deck or slab
- Stringer (S1 – S4)
- Floorbeam (FB0 – FB15)

- Girder (G1, G2)
- Truss chord (U0U1 – U.S.)
- Truss diagonal (U0L2 – D.S.)
- Secondary bracing (Top Lat. Br. U0 U.S. to U1 D.S.)
- Arch
- Spandrel column (Col. 1 – Col. 14 – U.S.)
- Spandrel wall (U.S., D.S. or N, S, E, W)
- Abutment (Abut. 1, Abut. 2)
- Pier (P1 – P4)

Verify that element descriptions or abbreviations are consistent with bridge owner nomenclature.

### **Structure Site Orientation**

Structure site orientation is normally established according to highway direction of inventory, mile markers, segments, or stationing. It is important that the orientation of each bridge be clearly established. The following are some examples:

- I79, Milepost 155.28 NB
- SR0019 Segment 05010
- Union Township, Alpha Drive, Station 109+05

### **Bridge Member Orientation**

When describing bridge members, it is important to clearly identify the specific element or member that has the deficiency. The following are some examples to orient bridge members:

- Substructure units (e.g., Abutment 1 and Pier 3) (see Figure 4.4.9).
- Floorbeam ends are identified by left/right looking in the direction of inventory or north/south or east/west designations.
- Sides of members can be identified by direction (e.g., “south side of Floorbeam 2” or “northeast elevation of Beam 4”).
- Span numbers and bay numbers to identify general areas on the bridge (see Figure 4.4.9).
- Individual beams or stringers left to right, looking in the direction of inventory (see Figure 4.4.10).
- Upstream or downstream designations can be assigned to structures over waterways (e.g., “upstream truss”, “downstream girder”, or “upstream arch”) (see Figure 4.4.11).
- For truss elements, identify the member with joint designations and specify if it is an upstream/downstream or north/south truss (see Figure 4.4.12). Number floorbeams in accordance with the panel point numbers.

If the orientation used during the inspection differs in any way with that used in existing documents, clearly state these differences in the inspection notes.

ELEVATION VIEW

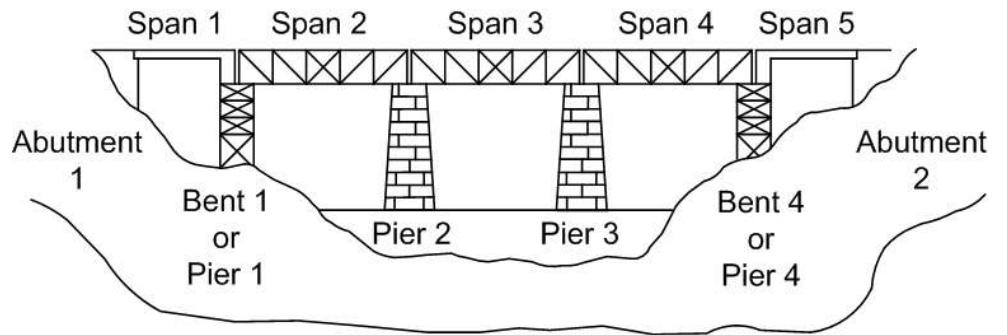


Figure 4.4.9 Sample Span Numbering Scheme

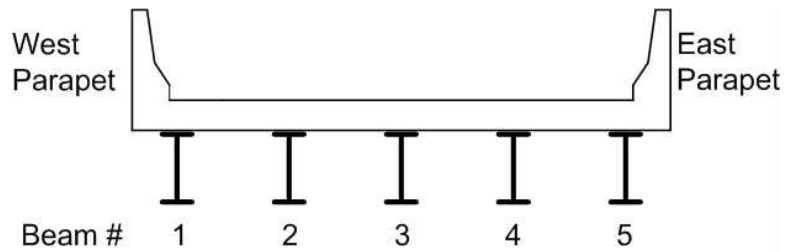
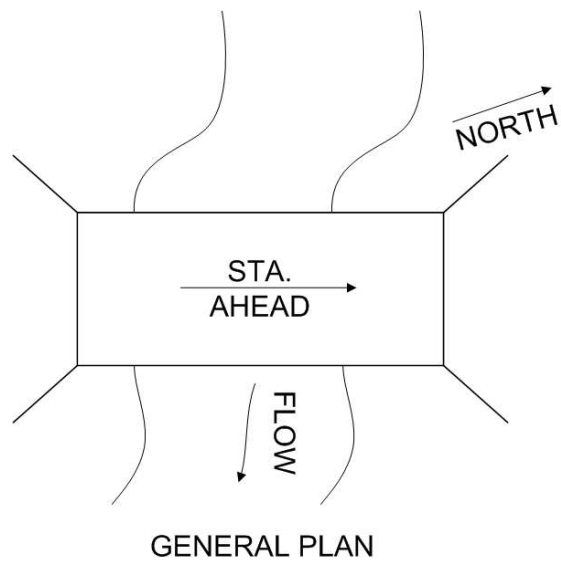


Figure 4.4.10 Sample Typical Section Numbering Scheme



GENERAL PLAN

Figure 4.4.11 Sample Structure Orientation Sketch



ELEVATION VIEW

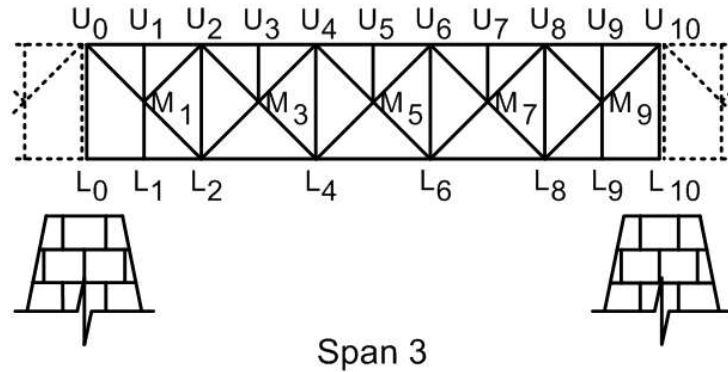


Figure 4.4.12 Sample Truss Numbering Scheme

Element Dimensions

Document sufficient dimensions to establish the size or cross section and other pertinent dimensions of elements. These include:

- Deck elements: length, width, and thickness
- Superstructure elements (beam, girder, floorbeam, stringer, and truss member): length, depth, width, flanges, and webs (see Figures 4.4.13 and 4.4.14)
- Substructure elements (abutment, columns and caps): width and depth (for rectangular shapes), diameter (for round columns), length, spacing, and pile batter and spacing (for pile bents)

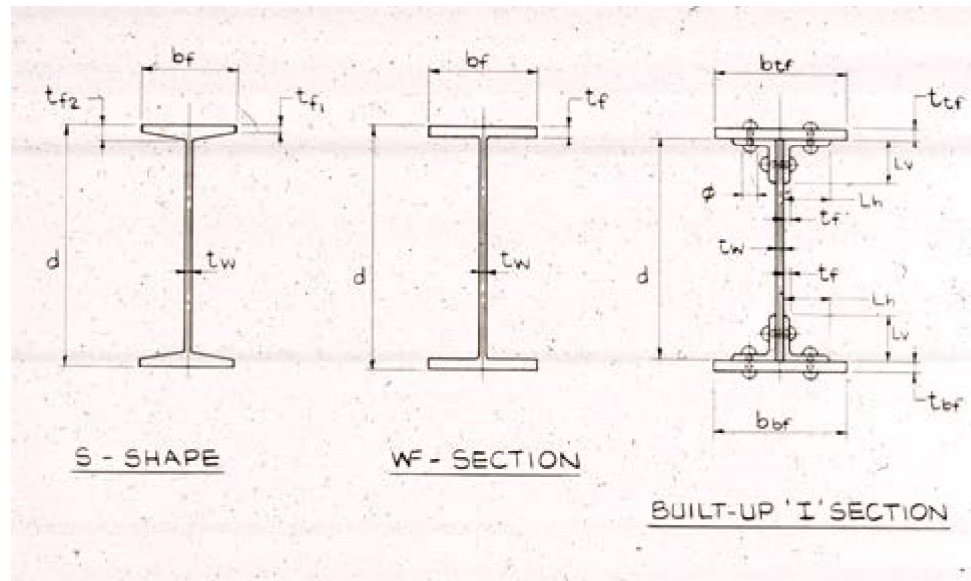
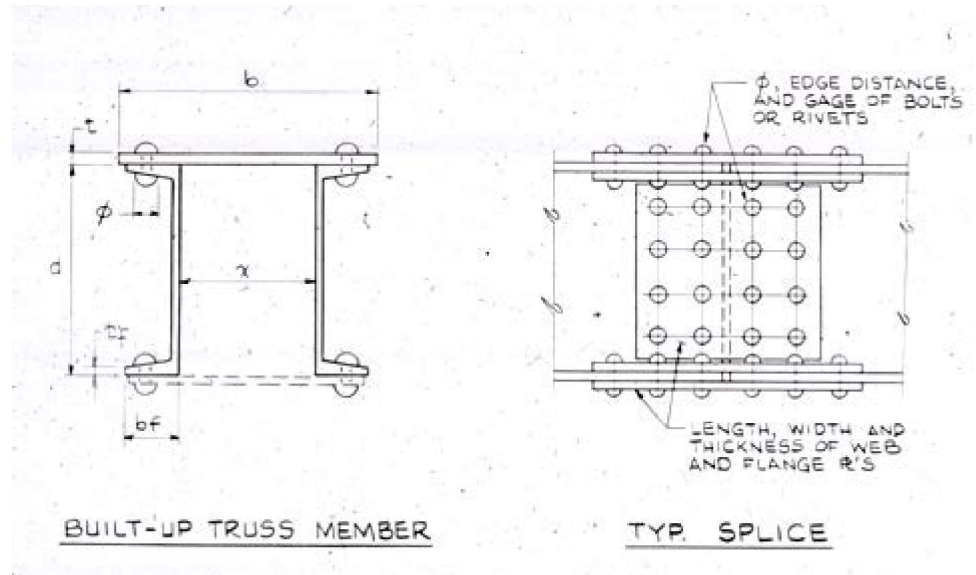


Figure 4.4.13 Steel Superstructure Dimensions



**Figure 4.4.14** Truss Member and Field Splice Dimensions

Exact member dimensions are required to determine section properties used to calculate a load-rating analysis.

### Inspection Notes and Sketches

In most cases, it will be possible to insert reproductions of portions of the plans in the inspection notes. However, in some instances, sketches will have to be drawn. The inspector may be able to pre-draw the sketches in the office and fill them out in the field (see Figures 4.4.15 through 4.4.17).

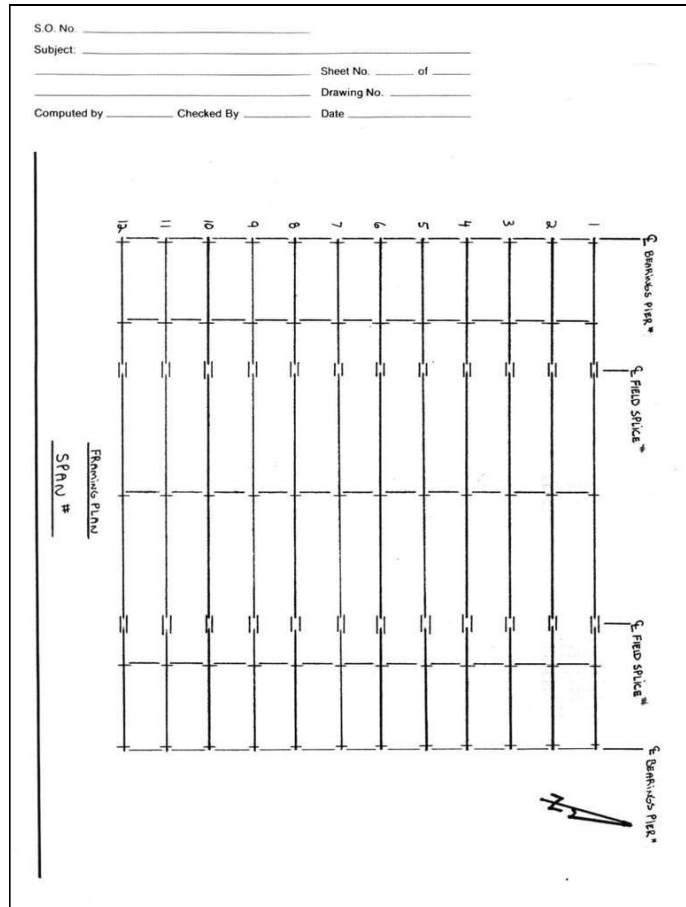


Figure 4.4.15 Framing Plan

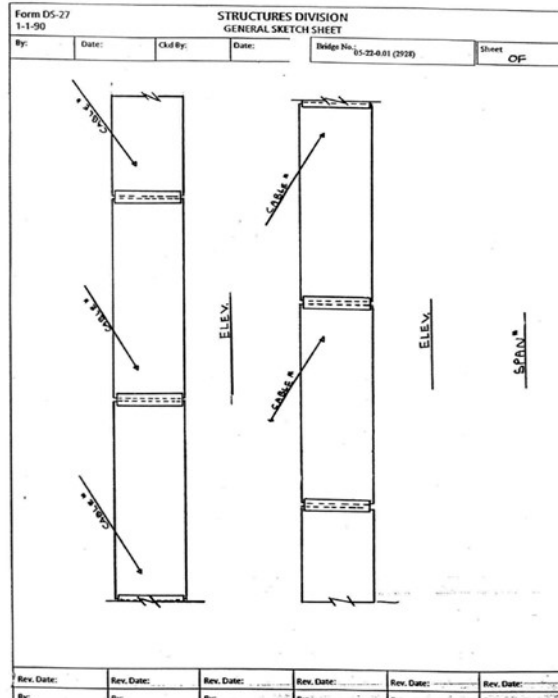


Figure 4.4.16 Girder Elevation

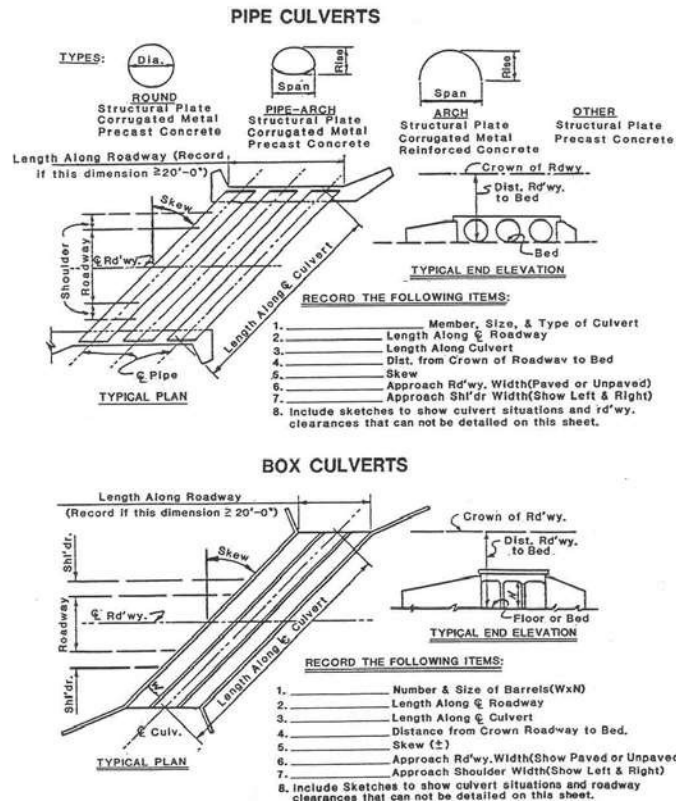
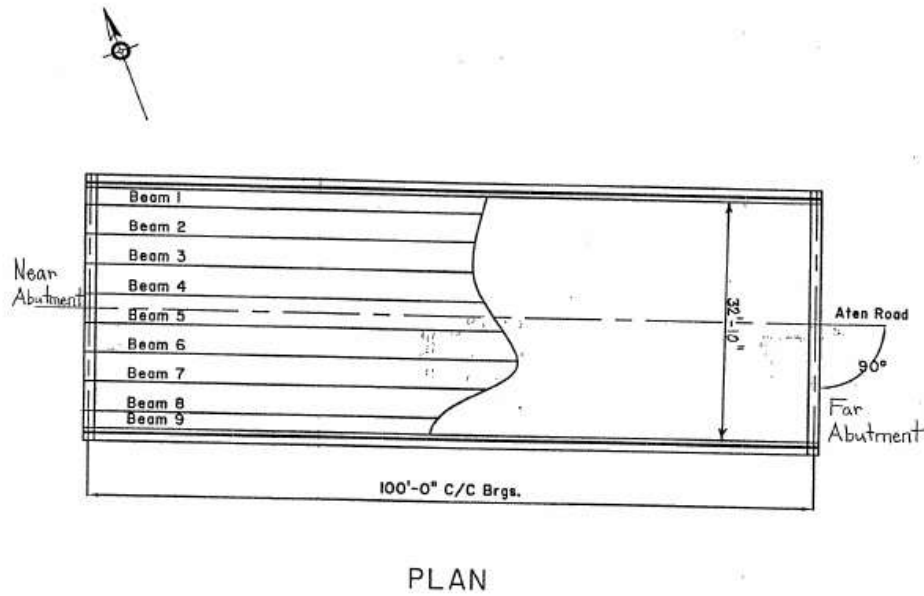
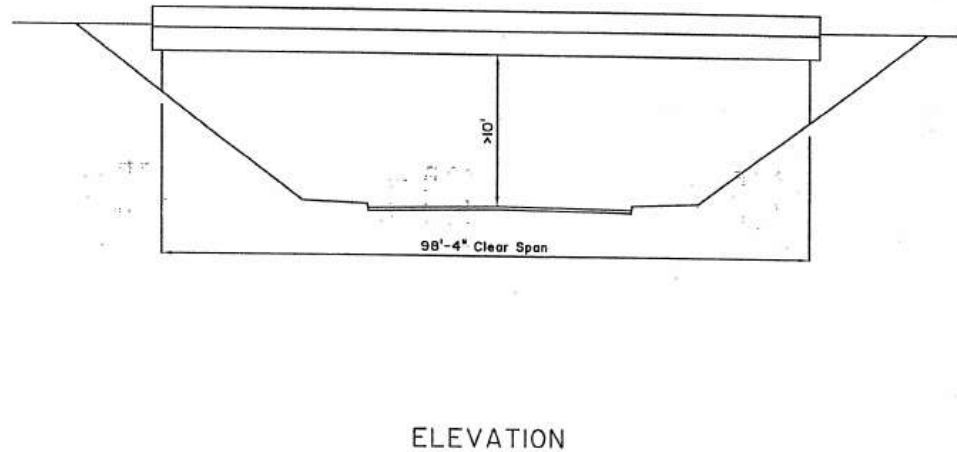


Figure 4.4.17 Typical Prepared Culvert Sketches

The first sketch in the field inspection notes normally portrays the general layout of the bridge and site information, illustrating the structure plan and elevation data (see Figures 4.4.18 and 4.4.19). The immediate area, the stream or terrain obstacle layout, major utilities, and any other pertinent details are also included.



**Figure 4.4.18** Sample General Plan Sketch



**Figure 4.4.19** Sample General Elevation Sketch

**Deficiency Identification** Identify material deficiencies. as presented in Topic 6.1 – Timber, Topic 6.2 – Concrete, Topic 6.3 – Steel, Topic 6.5 – Masonry.

The exact location, severity and extent of deficiencies are used to determine the capacity of the bridge in its current condition.

**Deficiency Qualification** Describe the seriousness of a deficiency. For example:

- Crack sizes – record lengths, widths, and depth
- Section loss – record the remaining section dimensions (when reporting section loss, it is important to document the section remaining rather than trying to estimate the percentage of section loss)
- Deformation – record the amount of misalignment

**Deficiency Quantification** Describe the quantity of a deficiency. For example:

- Spalling – 2 feet x 3 feet x 2 inches deep
- Scaling – 4 feet high by full abutment width
- Delamination – 1 foot x 6 inches
- Decay – 2 feet x 2 feet x 3 inches deep

**Deficiency Location**

The exact position of the deficiency on the element or member is required if load capacity analysis is to be performed. For example:

- Left side of web, top half, 3 feet from north bearing
- Top of top flange, from 3 feet to 6 feet west of Pier 2

The accuracy of the load capacity analysis depends on precise location information for deficiencies:

- Bending moment – Maximum positive moment occurs at or near midspan. Maximum negative moment occurs at the intermediate supports if the structure is continuous.
- Shear/bearing – Shear is maximum at or near the supports. Bearing is maximum at the supports.
- Axial compression members – The capacity of the member to resist compressive forces is reduced by any deformation or change in cross section. The potential capacity reduction is not dependent on where on the member the deficiency is located. All segments are critical.
- Axial tension members – These members experience a reduction in capacity through loss of section or from cracking. As with the axial compressive members, tensile members are equally susceptible regardless of the location of the deficiency.
- Combinations – While axial members are critical at all locations, it is not always apparent which members are loaded only in an axial direction. In fact, due to the dead load of the member itself, most are not. Other factors can also contribute to bending forces that will create varying moments, shears, compression, and tension areas within a member that is primarily axial. Because of this, identify the exact position of the deficiencies in all members using reference points, regardless of the forces acting on the member.

Locating a deficiency may include tying it to an established permanent reference. Avoid using references that can change over time.



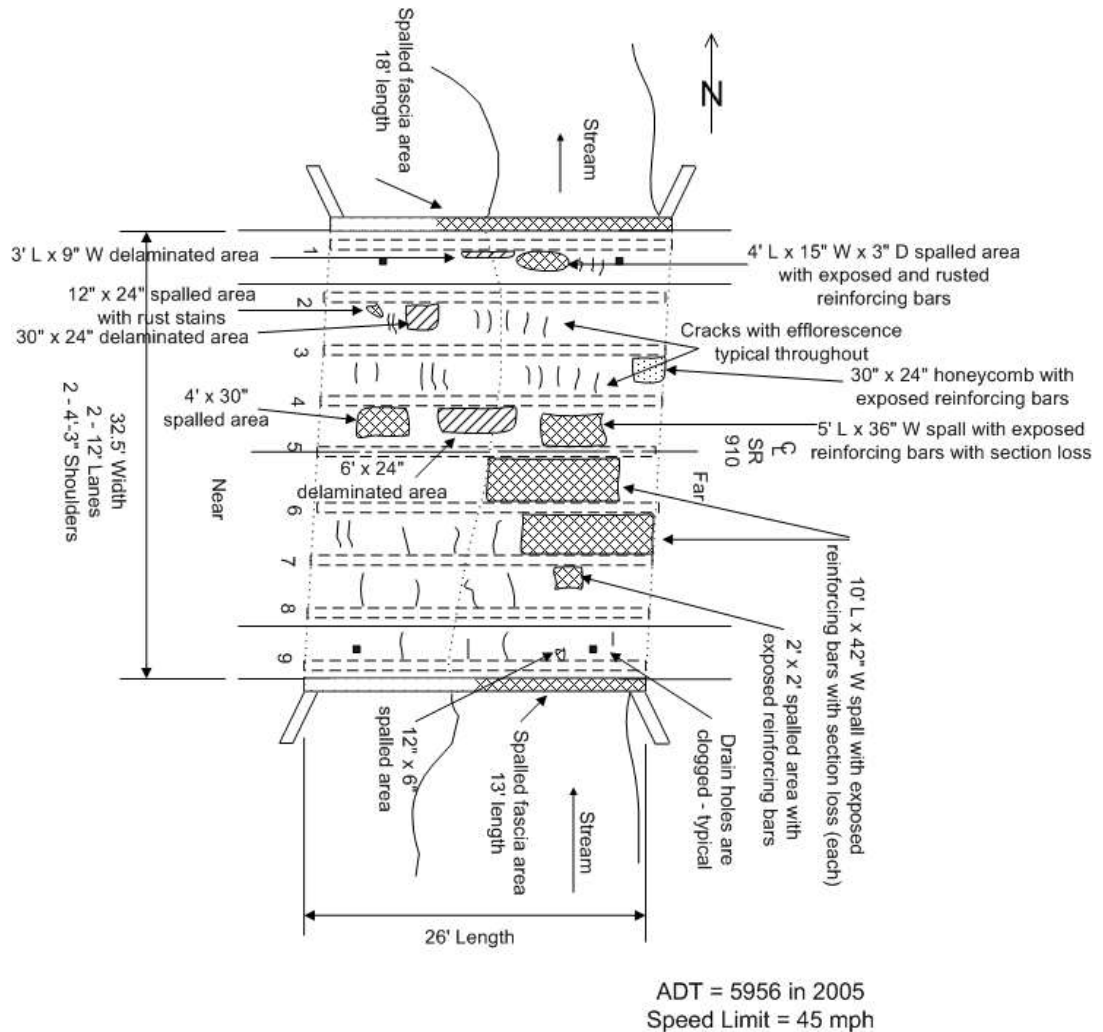
Some examples of proper referencing include:

- 7 feet-3 inches from fixed bearing on Beam 3 at Abutment 1
- 3 feet-1inch from west corner of Abutment 2
- 2 feet-6 inches below bridge seat on south face of Column 1, Pier 2

Reference points to avoid, since these locations vary between inspections:

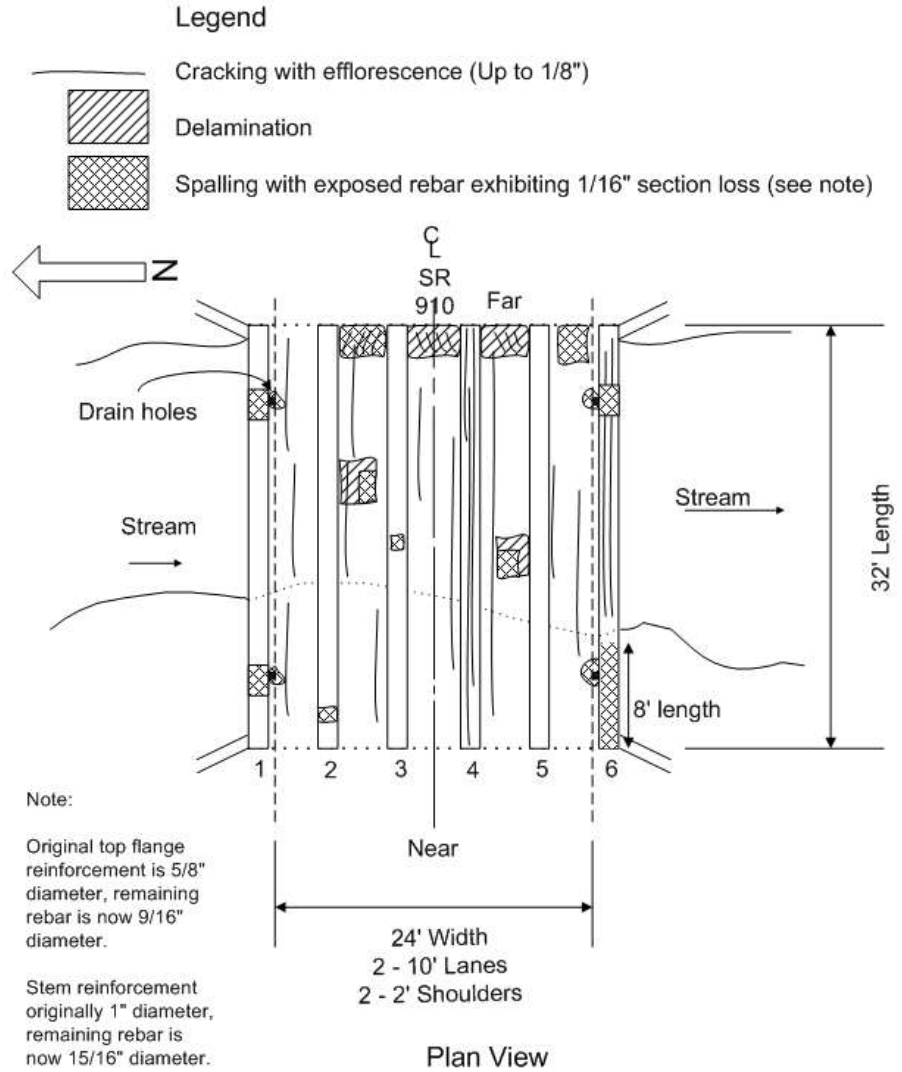
- Expansion rocker faces
- Ground levels, especially those that may be exposed to water
- Water levels

When documenting the deficiency locations on the deck, include the condition of deck and haunch, expansion joints, construction joints, curbs, sidewalks, parapets, and railings with the deck sketches (see Figure 4.4.20).



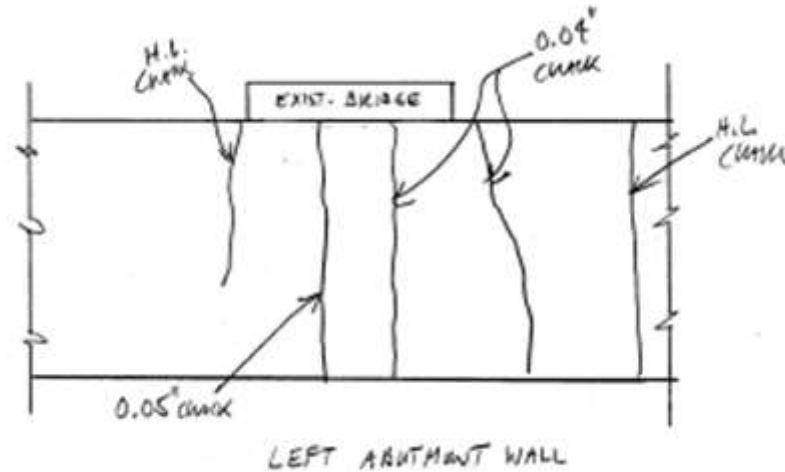
Plan View  
**Figure 4.4.20** Sample Deck Inspection Notes

When documenting the deficiency location of the superstructure, sketch the superstructure units in plan view and elevation, or cross section if necessary. Items to be inspected include bearings, main-supporting longitudinal members, floorbeams, stringers, bracing, and diaphragms (see Figure 4.4.21).



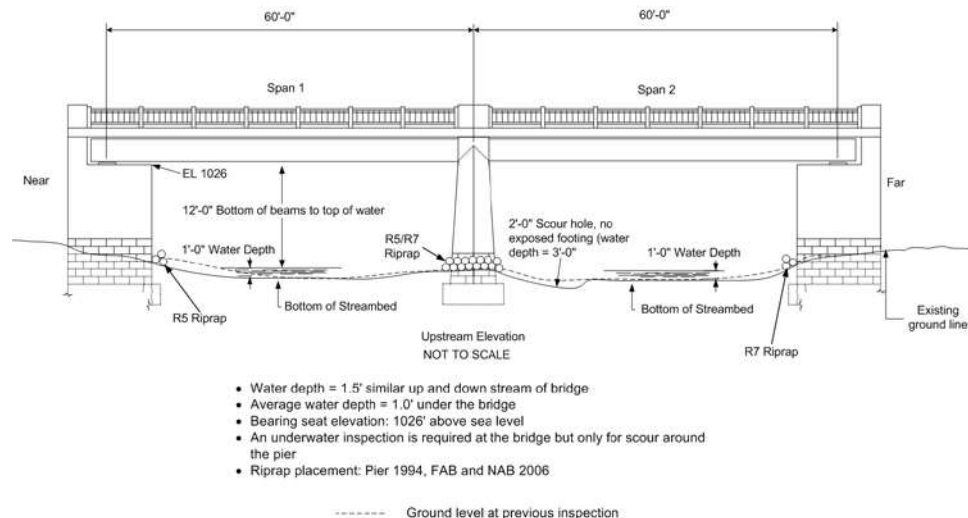
**Figure 4.4.21** Sample Superstructure Inspection Notes

Include sketches or drawings to describe the condition of each substructure unit (see Figure 4.4.22). In many cases, it is sufficient to draw typical units that identify the principal elements and deficiencies of the substructure. Identify each element of the substructure unit so that they can be cross referenced to the notes or sketches. Items to be identified include piling, footings, vertical supports, lateral bracing of members, and caps.



**Figure 4.4.22** Sample Substructure Inspection Notes

Include sketches or drawings to describe the condition of the channel (see Figure 4.4.23). Streambed materials, alignment, condition of the banks, and the condition of the bottom of the waterway (including scour holes) are included in the sketch.



**Figure 4.4.23** Sample Channel Inspection Notes

### Summary of Findings

Report all deficiencies, no matter how minor they may seem. Be as descriptive as necessary to report not only the severity of the deficiency but the location as well. This will be described in further detail later in this topic. When reporting deficiencies, be objective and do not use terms such as “dangerous” or “hazardous”.



SITE DATA  
 Form A

Form D-450A

**5A01** SR ID: \_\_\_\_\_ **5A03** BMS Ref: \_\_\_\_\_ **7A01** Inspection Date: \_\_\_\_\_

**1A09** Inspection Status: \_\_\_\_\_

**7A02** Team Leader: \_\_\_\_\_

**7A03** Inspection Type: \_\_\_\_\_

**7A05** Inspected By: \_\_\_\_\_

**Structure Description**

**5A08** FHWA Facility Carried: \_\_\_\_\_

**5A07** Features Intersected: \_\_\_\_\_

**5A09** Location: \_\_\_\_\_

**5C01** Roadway Name: \_\_\_\_\_

**5A06** City / Borough Name: \_\_\_\_\_

**Structure Type**

|                                |       |                                |       |
|--------------------------------|-------|--------------------------------|-------|
| <b>Main</b>                    |       | <b>Approach</b>                |       |
| <b>6A26</b> Material Makeup:   | _____ | <b>6A26</b> Material Makeup:   | _____ |
| <b>6A27</b> Physical Makeup:   | _____ | <b>6A27</b> Physical Makeup:   | _____ |
| <b>6A28</b> Span Interaction:  | _____ | <b>6A28</b> Span Interaction:  | _____ |
| <b>6A29</b> Structural Config: | _____ | <b>6A29</b> Structural Config: | _____ |

**Sign Information**

| Type of Sign                 | ID01        | ID02         | ID03     | ID06             | ID04            |         | ID07  | ID05  | Comments |
|------------------------------|-------------|--------------|----------|------------------|-----------------|---------|-------|-------|----------|
|                              |             |              |          |                  | Near            | Far     |       |       |          |
|                              | Sign Needed | Sign Message | Near Adv | Bridge Site Near | Bridge Site Far | Far Adv |       |       |          |
| 0 - Bridge                   | _____       | _____        | _____    | _____            | _____           | _____   | _____ | _____ | _____    |
| 1 - Bridge Weight Limit      | _____       | _____        | _____    | _____            | _____           | _____   | _____ | _____ | _____    |
| 2 - Except Combinations      | _____       | _____        | _____    | _____            | _____           | _____   | _____ | _____ | _____    |
| 3 - One Truck at a Time      | _____       | _____        | _____    | _____            | _____           | _____   | _____ | _____ | _____    |
| 4 - Vertical Clearance On    | _____       | _____        | _____    | _____            | _____           | _____   | _____ | _____ | _____    |
| 5 - Vertical Clearance Under | _____       | _____        | _____    | _____            | _____           | _____   | _____ | _____ | _____    |
| 6 - One Lane Bridge          | _____       | _____        | _____    | _____            | _____           | _____   | _____ | _____ | _____    |
| 7 - Narrow Bridge            | _____       | _____        | _____    | _____            | _____           | _____   | _____ | _____ | _____    |
| 8 - Hazardous Clearance      | _____       | _____        | _____    | _____            | _____           | _____   | _____ | _____ | _____    |
| 9 - Other                    | _____       | _____        | _____    | _____            | _____           | _____   | _____ | _____ | _____    |

Report Version Date:

Page 1 of 3

*This document includes structure safety inspection information that is confidential pursuant to 65 P.S. §66.1 et seq., 75 PA. C.S. §3754 and 23 U.S.C. §409 and may not be disclosed or used in litigation.*

**Figure 4.4.24** Example Inspection Form – PennDOT Form D-450



SITE DATA  
Form A

Form D-450A

**5A01** SR ID: \_\_\_\_\_ **5A03** BMS Ref: \_\_\_\_\_ **7A01** Inspection Date: \_\_\_\_\_

Features Intersected

| <b>6C02</b> |     | <b>5C03</b> |            | <b>5C06</b> | <b>5C29</b> | <b>4A20</b>  | <b>4A19</b> | <b>6C18</b>  | <b>6C19</b> | <b>6C20</b>  | <b>6C21</b>    | <b>6C22</b>  | <b>6C23</b>     | <b>6C24</b> | <b>6B17</b> |
|-------------|-----|-------------|------------|-------------|-------------|--------------|-------------|--------------|-------------|--------------|----------------|--------------|-----------------|-------------|-------------|
| SR ID       | Seg | On/Under    | Skew Angle | Dir         | NHS         | Min Lat Left | CI Right    | Tot Hor Left | CI Right    | Min Vrt Left | CI Rdwys Right | Vert CI Left | Over 10ft Right | VT Sign     | ADT         |
|             |     |             |            |             |             |              |             |              |             |              |                |              |                 |             |             |
|             |     |             |            |             |             |              |             |              |             |              |                |              |                 |             |             |
|             |     |             |            |             |             |              |             |              |             |              |                |              |                 |             |             |
|             |     |             |            |             |             |              |             |              |             |              |                |              |                 |             |             |
|             |     |             |            |             |             |              |             |              |             |              |                |              |                 |             |             |
|             |     |             |            |             |             |              |             |              |             |              |                |              |                 |             |             |

**6B15** Design Exceptions: \_\_\_\_\_  
**6A51** Sub Latent Problem: \_\_\_\_\_  
**6A50** Sup Latent Problem: \_\_\_\_\_

Deck Geometry

Table Used for Appraisal: \_\_\_\_\_

Controlling Values

**5C10** ADT: \_\_\_\_\_  
**5C27** Bridge Road Width: \_\_\_\_\_  
**4A10** Appraisal: \_\_\_\_\_  
 Notes: \_\_\_\_\_

**4A11** Underclr Appr: \_\_\_\_\_  
**6B13** Controlling Vertical: \_\_\_\_\_  
 Controlling Lateral: \_\_\_\_\_

Traffic Safety Features

| Feature Type           | <b>IA01</b><br>Location | <b>IA02</b><br>Adequacy Rating | <b>IA03</b><br>Description | <b>5C08</b><br>Posted Spd Lmt (mph) |
|------------------------|-------------------------|--------------------------------|----------------------------|-------------------------------------|
| 1 - Railing            | _____                   | _____                          | _____                      | _____                               |
| <b>Comment:</b>        | _____                   |                                |                            |                                     |
| 2 - Transition         | _____                   | _____                          | _____                      | _____                               |
| <b>Comment:</b>        | _____                   |                                |                            |                                     |
| 3 - Approach Guiderail | _____                   | _____                          | _____                      | _____                               |
| <b>Comment:</b>        | _____                   |                                |                            |                                     |
| 4 - Approach Railend   | _____                   | _____                          | _____                      | _____                               |
| <b>Comment:</b>        | _____                   |                                |                            |                                     |

Report Version Date:

Page 2 of 3

*This document includes structure safety inspection information that is confidential pursuant to 65 P.S. §66.1 et seq., 75 PA. C.S. §3754 and 23 U.S.C. §409 and may not be disclosed or used in litigation.*

Figure 4.4.24 Example Inspection Form – PennDOT Form D-450 (continued)



DECK AND SUPER STRUCTURE DATA  
 Form B

Form D-450B

**5A01** SR ID: \_\_\_\_\_ **5A03** BMS Ref: \_\_\_\_\_ **7A01** Inspection Date: \_\_\_\_\_

Deck Wearing Surface

|   |  |
|---|--|
| <p><b>Main</b></p> <p><b>5B02</b> Type of Wearing Surface: _____</p> <p><b>5B03</b> Type of Memb. Water-Proof: _____</p> <p><b>5B04</b> Deck Corrosion Protection: _____</p> <p><b>6A33</b> Thickness: _____</p> <p><b>6A34</b> Date Recorded: _____</p> <p><b>6B40</b> Condition Rating: _____</p> <p><b>IC02</b> DK WS Notes: _____</p> | <p><b>Approach</b></p> <p><b>6A30</b> Type of Wearing Surface: _____</p> <p><b>6A31</b> Type of Memb. Water-Proof: _____</p> <p><b>6A32</b> Deck Corrosion Protection: _____</p> <p><b>6A33</b> Thickness: _____</p> <p><b>6A34</b> Date Recorded: _____</p> |
|---|--|

Expansion Joints **6A41** Number of Expansion Joints: \_\_\_\_\_

|              | <b>VD25</b><br>Joint Type | <b>VD26</b><br>Movement Class | <b>VD27</b><br>Manufacture Code |
|--------------|---------------------------|-------------------------------|---------------------------------|
| Joint Number |                           |                               |                                 |
|              |                           |                               |                                 |
|              |                           |                               |                                 |
|              |                           |                               |                                 |

Deck

**1A01** Condition Rating: \_\_\_\_\_

**6B07** Est. Spall Delamination: \_\_\_\_\_ **6B08** Date: \_\_\_\_\_

**6B10** Est. Chloride Content: \_\_\_\_\_ **6B11** Date: \_\_\_\_\_

**1A07** Unrepaired Spalls: \_\_\_\_\_

Deck Top: \_\_\_\_\_

Deck Underside: \_\_\_\_\_

Deck Drainage: \_\_\_\_\_

Expansion Joints: \_\_\_\_\_

Deck Notes: \_\_\_\_\_

Report Version Date:

Page 1 of 2

*This document includes structure safety inspection information that is confidential pursuant to 65 P.S. §66.1 et seq., 75 PA. C.S. §3754 and 23 U.S.C. §409 and may not be disclosed or used in litigation.*

Figure 4.4.24 Example Inspection Form – PennDOT Form D-450 (continued)





DECK AND SUPER STRUCTURE DATA  
Form B

Form D-450B

**5A01** SR ID: \_\_\_\_\_ **5A03** BMS Ref: \_\_\_\_\_ **7A01** Inspection Date: \_\_\_\_\_

**Superstructure**

**1A04** Condition Rating: \_\_\_\_\_

Narrative: \_\_\_\_\_  
\_\_\_\_\_  
\_\_\_\_\_

Girders/Beams: \_\_\_\_\_

Floorbeams: \_\_\_\_\_

Stringers: \_\_\_\_\_

Diaphragms: \_\_\_\_\_

Truss Members: \_\_\_\_\_

Bearings: \_\_\_\_\_

Drainage System: \_\_\_\_\_

*This document includes structure safety inspection information that is confidential pursuant to 65 P.S. §66.1 et seq., 75 PA. C.S. §3754 and 23 U.S.C. §409 and may not be disclosed or used in litigation.*

**Figure 4.4.24** Example Inspection Form – PennDOT Form D-450 (continued)



ABUTMENT DATA  
Form C

Form D-450C

**5A01** SR ID: \_\_\_\_\_ **5A03** BMS Ref: \_\_\_\_\_ **7A01** Inspection Date: \_\_\_\_\_

**1A02** Substructure Condition Rating: \_\_\_\_\_

Notes: \_\_\_\_\_

**Near Abutment**

Backwall: \_\_\_\_\_

Bridge Seats: \_\_\_\_\_

Cheekwalls: \_\_\_\_\_

Stem: \_\_\_\_\_

Wings: \_\_\_\_\_

Footing: \_\_\_\_\_

Piles: \_\_\_\_\_

**IN20** Scour / Undermine: \_\_\_\_\_

Settlement: \_\_\_\_\_

Embank Slope-Wall: \_\_\_\_\_

Wall Drainage: \_\_\_\_\_

**Far Abutment**

Backwall: \_\_\_\_\_

Bridge Seats: \_\_\_\_\_

Cheekwalls: \_\_\_\_\_

Stem: \_\_\_\_\_

Wings: \_\_\_\_\_

Footing: \_\_\_\_\_

Piles: \_\_\_\_\_

**IN20** Scour / Undermine: \_\_\_\_\_

Settlement: \_\_\_\_\_

Embank Slope-Wall: \_\_\_\_\_

Wall Drainage: \_\_\_\_\_

Report Version Date:

Page 1 of 1

*This document includes structure safety inspection information that is confidential pursuant to 65 P.S. §66.1 et seq., 75 PA. C.S. §3754 and 23 U.S.C. §409 and may not be disclosed or used in litigation.*

**Figure 4.4.24** Example Inspection Form – PennDOT Form D-450 (continued)



PIER DATA  
 Form D

Form D-450D

**5A01** SR ID: \_\_\_\_\_ **5A03** BMS Ref: \_\_\_\_\_ **7A01** Inspection Date: \_\_\_\_\_

**4A21** Controls Exist: \_\_\_\_\_

**4A22** Vert Clearance: \_\_\_\_\_  
**4A24** Lift Vertical: \_\_\_\_\_  
**4A23** Horz Clearance: \_\_\_\_\_  
**4A07** Pier Protection: \_\_\_\_\_

Pier Details

**5D02** Pier/Bent Number: \_\_\_\_\_ **IN20** Scour / Undermine: \_\_\_\_\_

Condition Summary: \_\_\_\_\_  
 \_\_\_\_\_  
 \_\_\_\_\_

Bridge Seats: \_\_\_\_\_  
 \_\_\_\_\_

Cheekwalls: \_\_\_\_\_  
 Columns/Stems: \_\_\_\_\_  
 Settlement: \_\_\_\_\_

**5D02** Pier/Bent Number: \_\_\_\_\_ **IN20** Scour / Undermine: \_\_\_\_\_

Condition Summary: \_\_\_\_\_  
 \_\_\_\_\_  
 \_\_\_\_\_

Bridge Seats: \_\_\_\_\_  
 \_\_\_\_\_

Cheekwalls: \_\_\_\_\_  
 Columns/Stems: \_\_\_\_\_  
 Settlement: \_\_\_\_\_

**5D02** Pier/Bent Number: \_\_\_\_\_ **IN20** Scour / Undermine: \_\_\_\_\_

Condition Summary: \_\_\_\_\_  
 \_\_\_\_\_  
 \_\_\_\_\_

Bridge Seats: \_\_\_\_\_  
 \_\_\_\_\_

Cheekwalls: \_\_\_\_\_  
 Columns/Stems: \_\_\_\_\_  
 Settlement: \_\_\_\_\_

Report Version Date:

Page 1 of 1

*This document includes structure safety inspection information that is confidential pursuant to 65 P.S. §66.1 et seq., 75 PA. C.S. §3754 and 23 U.S.C. §409 and may not be disclosed or used in litigation.*

Figure 4.4.24 Example Inspection Form – PennDOT Form D-450 (continued)



ELEMENT DATA  
Form E

Form D-450E

**5A01** SR ID: \_\_\_\_\_ **5A03** BMS Ref: \_\_\_\_\_ **7A01** Inspection Date: \_\_\_\_\_

**6B03** Inventory Item Review Recommended: \_\_\_\_\_

**IC01** Notes: \_\_\_\_\_

Element Details

**5D02** Span: \_\_\_\_\_ **5D04** Span Type: \_\_\_\_\_

**1B01** Element ID: \_\_\_\_\_ Inspect by Each: \_\_\_\_\_

Environment: \_\_\_\_\_ **1B05** Scale Factor Measurement: \_\_\_\_\_

Description: \_\_\_\_\_

**1A10** Today QTY: \_\_\_\_\_ **1A11** Cond State 1 QTY: \_\_\_\_\_ **1A11** Cond State 2 QTY: \_\_\_\_\_

**1A11** Cond State 3 QTY: \_\_\_\_\_ **1A11** Cond State 4 QTY: \_\_\_\_\_ **1A11** Cond State 5 QTY: \_\_\_\_\_

Condition: \_\_\_\_\_

Report Version Date:

Page 1 of 1

*This document includes structure safety inspection information that is confidential pursuant to 65 P.S. §66.1 et seq., 75 PA. C.S. §3754 and 23 U.S.C. §409 and may not be disclosed or used in litigation.*

Figure 4.4.24 Example Inspection Form – PennDOT Form D-450 (continued)



FRACTURE CRITICAL  
Form F

Form D-450F

**5A01** SR ID: \_\_\_\_\_ **5A03** BMS Ref: \_\_\_\_\_ **7A01** Inspection Date: \_\_\_\_\_

Main

**6A44** Group: \_\_\_\_\_  
Critical Rating Factor: \_\_\_\_\_  
Total Critical Rating Factor: \_\_\_\_\_

Structure Type

**6A26** Material Makeup: \_\_\_\_\_  
**6A27** Physical Makeup: \_\_\_\_\_  
**6A28** Span Interaction: \_\_\_\_\_  
**6A29** Structural Config: \_\_\_\_\_

Approach

**6A44** Group: \_\_\_\_\_  
Critical Rating Factor: \_\_\_\_\_  
Total Critical Rating Factor: \_\_\_\_\_

Structure Type

**6A26** Material Makeup: \_\_\_\_\_  
**6A27** Physical Makeup: \_\_\_\_\_  
**6A28** Span Interaction: \_\_\_\_\_  
**6A29** Structural Config: \_\_\_\_\_

Fracture Critical Details

**IF01** Location: \_\_\_\_\_ **IF02** Type: \_\_\_\_\_ **IF05** FC Stress Category: \_\_\_\_\_  
**IF03** Member: \_\_\_\_\_  
**IF04** Member Detail: \_\_\_\_\_  
**IF06** Notes: \_\_\_\_\_

Report Version Date:

Page 1 of 1

*This document includes structure safety inspection information that is confidential pursuant to 65 P.S. §66.1 et seq., 75 PA. C.S. §3754 and 23 U.S.C. §409 and may not be disclosed or used in litigation.*

Figure 4.4.24 Example Inspection Form – PennDOT Form D-450 (continued)



UNDERWATER INSPECTION  
 Form G

Form D-450G

**5A01** SR ID: \_\_\_\_\_ **5A03** BMS Ref: \_\_\_\_\_ **7A01** Inspection Date: \_\_\_\_\_

**IU00a** UW Reviewer Action: \_\_\_\_\_  
**IU00b** Reviewer Comments: \_\_\_\_\_

**IU02** Number of Units: \_\_\_\_\_ **IU01** Recalculate SCBI: \_\_\_\_\_  
**IU03** SCBI Source: \_\_\_\_\_ **4A08** SCBI: \_\_\_\_\_

Overall SCBI: \_\_\_\_\_ SAR: \_\_\_\_\_  
**IU06** Streambed Material #1: \_\_\_\_\_  
**IU06** Streambed Material #2: \_\_\_\_\_  
**IU07** Notes: \_\_\_\_\_

Current Countermeasures

| CM Num | <b>IU21</b><br>Type | <b>IU22</b><br>Location | <b>IU23</b><br>Condition | <b>IU24</b><br>Subunit |
|--------|---------------------|-------------------------|--------------------------|------------------------|
|        |                     |                         |                          |                        |

Possible Countermeasures

| PCM Num | <b>IU25</b><br>Location | <b>IU26</b><br>Work Candidate |
|---------|-------------------------|-------------------------------|
|         |                         |                               |

SAR Calculation Data

**IU08** Debris Potential: \_\_\_\_\_  
**IU09** Trapping Potential: \_\_\_\_\_  
**IU10** Pressure Flow: \_\_\_\_\_  
**IU11** NAB Location: \_\_\_\_\_ **IU12** FAB Location: \_\_\_\_\_

US Left Wingwall  
**IU13** Presence: \_\_\_\_\_ **IU14** Condition: \_\_\_\_\_

US Right Wingwall  
**IU15** Presence: \_\_\_\_\_ **IU16** Condition: \_\_\_\_\_

Horizontal Debris Blockage  
**IU17** Start: \_\_\_\_\_ **IU18** End: \_\_\_\_\_

Vertical Debris Blockage  
**IU19** Start: \_\_\_\_\_ **IU20** End: \_\_\_\_\_

Report Version Date:

Page 1 of 2

*This document includes structure safety inspection information that is confidential pursuant to 65 P.S. §66.1 et seq., 75 PA. C.S. §3754 and 23 U.S.C. §409 and may not be disclosed or used in litigation.*

Figure 4.4.24 Example Inspection Form – PennDOT Form D-450 (continued)





UNDERWATER INSPECTION  
 Form G

Form D-450G

**5A01** SR ID: \_\_\_\_\_ **5A03** BMS Ref: \_\_\_\_\_ **7A01** Inspection Date: \_\_\_\_\_

Sub Unit OSA Data

Observed Scour Rating Components

| <b>IN01</b> | <b>IN12</b>     | <b>IN13</b>     | <b>IN14</b> | <b>IN15</b> | <b>IN19</b> | <b>IN04</b>         | <b>IN05</b> | <b>IN06</b>      | <b>IN07</b>   | <b>IN08</b>             | <b>IN09</b> | <b>IN10</b> | <b>IN11</b>            | <b>IN03</b>           |
|-------------|-----------------|-----------------|-------------|-------------|-------------|---------------------|-------------|------------------|---------------|-------------------------|-------------|-------------|------------------------|-----------------------|
| Sub Unit    | Pier/ Abut Type | Inv. Found Type | Found Type  | Strmbd Mat  | Move Ind    | Chg Since Last Insp | Scour Hole  | Debris Potential | Scour-ability | Opening Adeq. / Channel | Sediment    | Alignment   | Velocity/ Stream Slope | Observed Scour Rating |
|             |                 |                 |             |             |             |                     |             |                  |               |                         |             |             |                        |                       |
|             |                 |                 |             |             |             |                     |             |                  |               |                         |             |             |                        |                       |
|             |                 |                 |             |             |             |                     |             |                  |               |                         |             |             |                        |                       |
|             |                 |                 |             |             |             |                     |             |                  |               |                         |             |             |                        |                       |

Other Subunit Details

| <b>IN01</b> | <b>IN16</b>  | <b>IN18</b> | <b>IN17</b>          | <b>IN20</b>     | <b>IN21</b>      | <b>IN02</b>            | <b>IN22</b>                   | <b>IN23</b>                   |           |     |
|-------------|--------------|-------------|----------------------|-----------------|------------------|------------------------|-------------------------------|-------------------------------|-----------|-----|
| Sub Unit    | UW Insp Type | Water Dept  | Observed Scour Depth | Scour Undermine | Counter-measures | Info from Current Insp | 100 yr Flood Calc Scour Depth | 500 yr Flood Calc Scour Depth | SCBI Code | SAR |
|             |              |             |                      |                 |                  |                        |                               |                               |           |     |
|             |              |             |                      |                 |                  |                        |                               |                               |           |     |

**IN24** Notes: \_\_\_\_\_

**IN24** Notes: \_\_\_\_\_

**IN24** Notes: \_\_\_\_\_

**IN24** Notes: \_\_\_\_\_

Underclearance

**IL09** Origin Description: \_\_\_\_\_  
**IL10** Horizontal: \_\_\_\_\_  
**IL11** Vertical: \_\_\_\_\_  
**IL12** Notes: \_\_\_\_\_

Report Version Date: \_\_\_\_\_

Page 2 of 2

*This document includes structure safety inspection information that is confidential per 75 PA. C.S. §3754 and 23 U.S.C. §409 and may not be disclosed or used for any other purpose.*

Figure 4.4.24 Example Inspection Form – PennDOT Form D-450 (continued)



CULVERT DATA  
 Form H

Form D-450H

**5A01** SR ID: \_\_\_\_\_ **5A03** BMS Ref: \_\_\_\_\_ **7A01** Inspection Date: \_\_\_\_\_

**1A03** Culvert Condition Rating: \_\_\_\_\_

Notes: \_\_\_\_\_

**5B18** Length of Culvert Barrel: \_\_\_\_\_

| # | Opening Type | Length | Min Fill Height | Max Fill Height | Eff Width |
|---|--------------|--------|-----------------|-----------------|-----------|
|   |              |        |                 |                 |           |

Top Slab: \_\_\_\_\_  
 Barrel: \_\_\_\_\_  
 Floor/Paving: \_\_\_\_\_  
 Headwall: \_\_\_\_\_  
 Wings: \_\_\_\_\_  
 Settlement: \_\_\_\_\_  
 Debris: \_\_\_\_\_

Report Version Date:

Page 1 of 1

*This document includes structure safety inspection information that is confidential pursuant to 65 P.S. §66.1 et seq., 75 PA. C.S. §3754 and 23 U.S.C. §409 and may not be disclosed or used in litigation.*

**Figure 4.4.24** Example Inspection Form – PennDOT Form D-450 (continued)



CHANNEL AND WATERWAY DATA  
Form J

Form D-450H

**5A01** SR ID: \_\_\_\_\_ **5A03** BMS Ref: \_\_\_\_\_ **7A01** Inspection Date: \_\_\_\_\_

**Channel**

**1A05** Channel/ Channel Protection Cond. Rating: \_\_\_\_\_

Channel: \_\_\_\_\_

Banks: \_\_\_\_\_

Streambed Movements: \_\_\_\_\_

Debris, Vegetation: \_\_\_\_\_

River Control Devices: \_\_\_\_\_

Embank/Strmbed Contr: \_\_\_\_\_

Drift, Other: \_\_\_\_\_

**Waterway Adequacy**

**1A06** Appraisal Code: \_\_\_\_\_

Notes: \_\_\_\_\_

**IL02** Overtop Risk: \_\_\_\_\_

**IL03** Traffic Delay: \_\_\_\_\_

**5C22** Functional Class: \_\_\_\_\_

**High Water Mark**

**IL05** Elevation: \_\_\_\_\_ **IL06** Date: \_\_\_\_\_ **IL07** New High Water Mark: \_\_\_\_\_

Notes: \_\_\_\_\_

Report Version Date:

Page 1 of 1

*This document includes structure safety inspection information that is confidential pursuant to 65 P.S. §66.1 et seq., 75 PA. C.S. §3754 and 23 U.S.C. §409 and may not be disclosed or used in litigation.*

Figure 4.4.24 Example Inspection Form – PennDOT Form D-450 (continued)



PAINT, STRUCTURE APPRAISAL AND LOAD RATINGS  
 Form K

Form D-450K

**5A01** SR ID: \_\_\_\_\_ **5A03** BMS Ref: \_\_\_\_\_ **7A01** Inspection Date: \_\_\_\_\_

**Paint Condition**

**6B36** Paint Cond Rating: \_\_\_\_\_ **6B37** Ext of Paint Cond: \_\_\_\_\_  
**6B35** New Paint: \_\_\_\_\_  
 Int Beam / Gird: \_\_\_\_\_  
 Fascias: \_\_\_\_\_  
 Splsh Zone: Truss Gird: \_\_\_\_\_  
 Truss: \_\_\_\_\_  
 Bearings: \_\_\_\_\_  
 Other: \_\_\_\_\_

**4B03** Bridge Cap. Appraisal: \_\_\_\_\_  
**6B16** Controlling: \_\_\_\_\_  
**4A09** Struct Cond Appraisal: \_\_\_\_\_

Structure Condition Appraisal Based on  
 \_\_\_\_\_

**Load Ratings**

**4B15** Load Rating Review Recommended: \_\_\_\_\_  
 Due To: \_\_\_\_\_  
 Calculation Date: \_\_\_\_\_  
 Rating Approval Date: \_\_\_\_\_

**Load Rating Details**

|      | <b>IR10</b> | <b>IR11</b> | <b>IR05</b> | <b>IR06</b> | <b>IR07</b> | <b>IR16</b> | <b>IR14</b> | <b>IR15</b> | <b>IR13</b> | <b>IR12</b> |
|------|-------------|-------------|-------------|-------------|-------------|-------------|-------------|-------------|-------------|-------------|
|      | IR          | OR          | NBI         | RTNG        | CONT        | ANALYSIS    | AASHTO      | AASHTO      | OPR         | INV         |
| LOAD | LOAD        | LOAD        | IND         | ANAL        | MEM         | ENGINEER    | MANUAL      | SPEC        | GOV         | GOV         |
| TYPE | LOAD        | LOAD        | IND         | METH        | TYPE        | ENGINEER    | YEAR        | YEAR        | CRITERIA    | CRITERIA    |

Notes: \_\_\_\_\_  
 -----  
 Notes: \_\_\_\_\_  
 -----  
 Notes: \_\_\_\_\_  
 -----  
 Notes: \_\_\_\_\_  
 -----

Report Version Date:

Page 1 of 1

*This document includes structure safety inspection information that is confidential pursuant to 65 P.S. §66.1 et seq., 75 PA. C.S. §3754 and 23 U.S.C. §409 and may not be disclosed or used in litigation.*

Figure 4.4.24 Example Inspection Form – PennDOT Form D-450 (continued)





INSPECTION ADMINISTRATION  
 Form P

Form D-450P

**5A01** SR ID: \_\_\_\_\_ **5A03** BMS Ref: \_\_\_\_\_ **7A01** Inspection Date: \_\_\_\_\_

**Current Inspection**

**7A03** Primary Type: \_\_\_\_\_

**7A06** Types of Inspections Performed:  
 NBI \_\_\_\_\_ Underwater \_\_\_\_\_ Element \_\_\_\_\_ Fracture Critical \_\_\_\_\_ Other Special \_\_\_\_\_

**Inspection Man Hours**

**6B26** NBI Crew: \_\_\_\_\_ **6B30** Underwater: \_\_\_\_\_  
**6B28** Fracture Critical: \_\_\_\_\_ **6B29** Other 1: \_\_\_\_\_  
**6B27** Crane: \_\_\_\_\_ **6B31** Other 2: \_\_\_\_\_

**Inspection Cost (in hundreds)**

**6B32** Engineering: \_\_\_\_\_ **6B33** Rigging: \_\_\_\_\_  
**6B34** Office: \_\_\_\_\_

**Special Equip Used:**

**6B12** Temperature: \_\_\_\_\_ **6B09** Weather: \_\_\_\_\_  
**6B03** Inventory Review Recommended: \_\_\_\_\_

Change Notes: \_\_\_\_\_

**Inspection Team**

**7A04** Inspected By: \_\_\_\_\_  
**7A02** Team Leader: \_\_\_\_\_  
**6B23** Team Member: \_\_\_\_\_  
**6B24** Hired By: \_\_\_\_\_  
**6B25** Insp Contract Num: \_\_\_\_\_  
**2A02** Inspection Notes: \_\_\_\_\_

**Next Inspection**

**7A14** Next Inspection By: \_\_\_\_\_  
**6B20** Next Insp Type: \_\_\_\_\_

**Schedule**

| Insp Types                     | <b>7A09</b><br>Required | <b>7A09</b><br>Frequency | <b>7A10</b><br>Next Date |
|--------------------------------|-------------------------|--------------------------|--------------------------|
| NBI                            | _____                   | _____                    | _____                    |
| Fracture Critical              | _____                   | _____                    | _____                    |
| Underwater                     | _____                   | _____                    | _____                    |
| Other Special                  | _____                   | _____                    | _____                    |
| Element                        | _____                   | _____                    | _____                    |
| Crane                          | _____                   | _____                    | <b>6B18</b> _____        |
| <b>6B01</b> Special Insp Type: | _____                   |                          |                          |

**Estimated Inspection Man Hours**

**7A12** NBI Crew: \_\_\_\_\_ **7A17** Underwater: \_\_\_\_\_  
**7A15** Fracture Critical: \_\_\_\_\_ **7A16** Other 1: \_\_\_\_\_  
**7A13** Crane: \_\_\_\_\_ **7A18** Other 2: \_\_\_\_\_

Report Version Date: \_\_\_\_\_ Page 1 of 1

*This document includes structure safety inspection information that is confidential pursuant to 65 P.S. §66.1 et seq., 75 PA. C.S. §3754 and 23 U.S.C. §409 and may not be disclosed or used in litigation.*

**Figure 4.4.24** Example Inspection Form – PennDOT Form D-450 (continued)



This page intentionally left blank

# Table of Contents

## Chapter 4 Bridge Inspection Reporting

---

|       |  |       |
|-------|--|-------|
| 4.5   | Critical Findings.....                       | 4.5.1 |
| 4.5.1 | Definition.....                              | 4.5.1 |
| 4.5.2 | Procedures.....                              | 4.5.1 |
|       | Procedures for Inspectors .....              | 4.5.2 |
|       | Office Priority Maintenance Procedures ..... | 4.5.4 |
|       | Bridge Closing Procedure.....                | 4.5.6 |
| 4.5.3 | Examples of Critical Findings.....           | 4.5.6 |
|       | Timber .....                                 | 4.5.6 |
|       | Concrete.....                                | 4.5.7 |
|       | Steel.....                                   | 4.5.8 |
|       | Roadside Hardware or Safety Features .....   | 4.5.8 |
|       | Signs and Lighting.....                      | 4.5.8 |
|       | Other.....                                   | 4.5.9 |
| 4.5.4 | Example Plans of Action.....                 | 4.5.9 |

This page intentionally left blank

# Topic 4.5 Critical Findings

## 4.5.1

### Definition

A critical finding are a structural or safety related deficiency that requires immediate follow-up inspection or action.

A structure related deficiencies can interrupt the load path, not allowing loads to be transferred as designed. This can cause surrounding elements to become overstressed or unstable, potentially leading to partial or total collapse of the structure. Critical findings may also be non-structural deficiencies which jeopardize the safety of motorists or pedestrians.

## 4.5.2

### Procedures

As stated in the NBIS regulations, each state or federal agency is required to "establish a statewide procedure to assure that critical findings are addressed in a timely manner." Although specific procedures vary among agencies, general steps must be taken to assure that critical findings are identified and resolved as quickly and efficiently as possible. The viable options available are permanently repair, temporarily repair or restrict loads on the bridge.

Currently, states employ two approaches to coding condition items when localized areas of severe deterioration are encountered. Some will account for the severity of a localized area of deterioration by lowering the condition rating of an entire component. The component condition rating is adjusted after the deteriorated area is improved (i.e., rating may rise if physical improvements are made, or may stay the same if the bridge is posted for load restrictions and/or supported with temporary shoring). FHWA recognizes this approach when the severity of the localized deterioration affects the load-carrying capacity of the component.

Other states rate to the general condition regardless of the severity of a localized area of deterioration. This approach relies heavily on ensuring that critical findings are addressed in a timely manner regardless of the component condition rating value. If the localized area of severe deterioration is not improved following the critical finding follow-up process, the component rating may need to be lowered to account for the severity of the deterioration if structural capacity is affected.

Either approach to coding the condition items results in the same ultimate outcome, i.e. critical inspection findings are addressed to allow continued safe use of the bridge. Component ratings eventually reflect the overall condition of the component. If the approach is to consider both the severity and extent of a component's deterioration in rating each component at the time of inspection (or up to 90 days after the inspection as required by the NBIS), there cannot be any assumptions about future improvements made to a localized area. Only if an improvement is made, the rating should then be raised as appropriate. If the improvement is made within 90 days of the inspection, there is no need to consider the localized deterioration in the rating.

Critical findings / critical follow-up report categorical contents with the documented status:

1. Bridges that have critical findings in the process of being addressed.
2. Bridges with work scheduled but not started yet.
3. Bridges that have no plan in the works.
4. Critical Finding is scour related.

### **Procedures for Inspectors**

Upon identifying a potential critical finding, immediately report the deficiency to the appropriate agency official, bridge owner, or governing authority. For most agencies, a verbal notification is required soon after identifying the potential critical deficiency.

In addition to a verbal notification, agencies require immediate written notification of the potential critical finding. This notification is often presented in a standardized hardcopy or electronic format (see Figures 4.5.1 and 4.5.2), and is submitted soon after the verbal notification for most agencies. The written notification serves to document the critical finding by describing the extent of the deficiency complete with notes, photographs, sketches and drawings, measurements, possible causes, and recommendations for repair. Temporary actions may also be taken at this time to safeguard the public until proper repairs can be completed. These actions may include:

- Load posting
- Traffic restrictions from the damaged area
- Speed restrictions
- Temporary lane closure
- Temporary shoring
- Complete bridge closure


After submittal of the written report, the finding will be assessed and the severity determined along with a proposed repair strategy or plan of action. In accordance with NBIS regulations, the agency is also required to notify the FHWA of the critical finding. Public works officials or law enforcement may also be contacted as needed.

**Missouri Department of Transportation  
Critical Inspection Finding  
State System**

|  |
|--|
| Bridge _____ District _____ County _____ Route _____ AADT _____<br>Location _____ Inspector _____ Inspection Date _____  |
| <b>Reason for Critical Inspection Finding report:</b> Be specific about deficiencies. Attach Photographs.<br><br>  |
| <b>Inspector's Immediate Recommendations:</b><br><input type="checkbox"/> Immediate Closure Required <input type="checkbox"/> Immediate Blocking/Shoring Required<br><input type="checkbox"/> Reduce traffic to one-lane. Carry traffic on <input type="checkbox"/> NB <input type="checkbox"/> SB <input type="checkbox"/> EB <input type="checkbox"/> WB lane<br><input type="checkbox"/> Other: _____ |
| <b>Immediate Notification:</b> <input type="checkbox"/> State BM Engr <input type="checkbox"/> Supv Bridge Insp Engr <input type="checkbox"/>  |
| <b>MoDOT Action Plan by Bridge Maintenance and the District:</b> _____ <b>Date:</b> _____  |
| <b>Follow-up Actions:</b> _____ <b>Completion Date:</b> _____  |

**Figure 4.5.1** Missouri DOT Critical Inspection Finding Form



|  |                           |   |
|--|---------------------------|---|
|  Washington State<br>Department of Transportation |                           | <b>Critical Damage - Bridge Repair Report</b> |
| Agency Name  | Charge Code               | Bridge Name                                   |
| Structure Identifier   | Bridge Number             | Bridge Location (Longitude/Latitude)          |
| Inspector (Print Name)   | Inspector's ID Number     | Inspection Date                               |
| Describe Deficiency  |                           |   |
| Describe Recommended Repair  |                           |   |
| Anticipated Date of Completion   | Submitted By (Print Name) | Date Submitted                                |
| Describe Work Done   |                           |   |
| Date of Completion   | Submitted By (Print Name) | Date  |

DOT Form 140-151 EF  
6/98

**Figure 4.5.2** Washington State DOT "Critical Damage - Bridge Repair Report"

**Office Priority  
 Maintenance  
 Procedures**

Agencies establish priority maintenance procedures and prioritization criteria to help facilitate maintenance work plan strategies. Most agency systems utilize between three and five different prioritization levels ranging from general housekeeping and routine repairs to critical findings requiring immediate action. Examples of agency priority maintenance procedures are listed below in the order of most critical to least critical, with a description of each level.

Oregon Department of Transportation (ODOT)

- "Significant" – Severe deficiency to a primary bridge element that requires complete or partial closure of the bridge, or an immediate load restriction of the bridge.
- "Critical" – Serious deficiency to a primary bridge element that needs repair to prevent the bridge from being load posted.
- "Urgent" – Traffic safety related concern that does not jeopardize the reliability of the transportation system, protection of public investments, or maintenance of legal federal mandates.
- "Routine/Schedule" – Minor to moderate deficiency to a primary bridge element or moderate to major deficiency to a secondary element.
- "Monitor" – Non-structural housekeeping repairs such as cleaning the deck and drainage systems.

North Carolina Department of Transportation (NCDOT)

- "Critical Finding" – Severe deficiency to a primary bridge element that could cause partial or complete collapse or a safety feature deficiency that may jeopardize the safety of the public.
- "Priority Maintenance need" – Serious deficiency that may lead to load posting and/or bridge closures if left untreated.
- "Routine Maintenance need" – Minor to moderate deficiencies to primary or secondary bridge elements or non-structural housekeeping repairs such as cleaning the deck and drainage systems.

Pennsylvania Department of Transportation (PennDOT)

- "0 – Critical" – Severe deficiency to a primary bridge element that could directly or indirectly cause partial or complete structure collapse or a safety feature deficiency that may result in loss of vehicle operator control or failure to contain errant vehicles on the bridge deck.
- "1 – High Priority" – Serious deficiency to a primary bridge element that may lead to load posting and/or bridge closures. If left untreated, the deficiency may also jeopardize public safety.
- "2 – Priority" – Advanced deficiency on a primary bridge element or appurtenance that if left untreated, may lead to continuing deterioration, load posting, or partial or complete bridge closures.
- "3 – Schedule" – Minor deficiency to a primary bridge element or appurtenance that may continue to deteriorate if left untreated.
- "4 – Program" – Note-worthy problem on a primary bridge element, secondary element, or appurtenance that may lead to a documentation-worthy deficiency if left untreated.
- "5 – Routine" – Non-structural housekeeping maintenance that may lead to deterioration of primary and secondary structural members if left untreated.

## Bridge Closing Procedure

In some situations, the bridge may need to be closed until the critical finding can be repaired. The decision to close the bridge may result from the nature of the critical finding upon initial discovery, an unacceptable timeframe in which the repairs are scheduled to be completed, or agency policy on critical findings.

For situations recommending closure of the bridge by the bridge inspector and/or bridge maintenance supervisor, follow established State or Federal Agency procedures. Examples of acceptable procedures include:

- Contact the Bridge Maintenance Supervisor about the recommended closing.
- Contact the Bridge Engineer about the recommended closing.
- If both the Bridge Maintenance Supervisor and Bridge Engineer are unavailable, contact the District or Division office about the recommended closing.

### 4.5.3

## Examples of Critical Findings

FHWA guidance for a follow-up may include a procedure where the State promptly submits to the Division office a copy of inspection reports or recommendations for all on-system and off-system bridges that meet the following criteria:

1. Bridges with recommendations for immediate work on fracture critical members;
2. Bridges with recommendations for immediate correction of scour or hydraulic problems;
3. Bridges with condition ratings of 3 or less for the superstructure or substructure or appraisal ratings of 3 or less for waterway adequacy; and
4. Bridges with recommendations for immediate work to prevent substantial reduction in the safe load capacity.

Source: <http://www.fhwa.dot.gov/bridge/0650csup.cfm>

Many state agencies publish examples of critical findings for bridge inspectors. It should be noted that these lists are not all-inclusive or comprehensive and should only be used as guidance in determining whether or not a deficiency is a critical finding.

The critical findings listed below are organized by material type and application. These deficiencies represent excerpts obtained from several agencies' critical finding documentation

## Timber

The following deficiencies represent examples of critical findings for timber:

- Through-loss in deck planks and broken planks in danger of breaking through.
- Primary structural members with collision damage that compromises the structural capacity (including severe section loss, full length horizontal cracking, and section loss to truss compression members producing

member buckling or severe flexural cracking).

- Primary structural members with multiple open cracks in high stress regions or crushing/decay that may lead to superstructure settlement.
- Crushed or broken nailer boards or broken joists.
- Piles and pier caps that have loss of bearing capacity or soil retention through crushing, decay, or insect damage.
- Substructure units with severe scour and undermining of the substructure foundation causing instability.

## Concrete

The following deficiencies represent examples of critical findings for concrete:

- Section loss (thru-hole) subject to enlargement by traffic or deep spalls with exposed rebar in danger of holing through, creating a safety hazard to passing traffic.
- Prestressed girder with spalling and broken strands or 100% deterioration at critical high stress areas.
- Non-composite prestressed adjacent box beams with serious deterioration and existing strand loss, loss of camber or torsional cracking.
- Reinforced concrete girder or pier cap with spalling and broken main rebar or 100% deterioration, with more than one bar affected at the same location in the girder.
- Reinforced or prestressed concrete girder bearing area resulting in loss of bearing area and making girder subject to settlement.
- Reinforced concrete columns with spalling and rebar section loss causing the column to be subject to failure.
- Primary structural members with collision damage that compromises the structural capacity (including severed prestressing tendons, reinforcing steel that results in flexural cracking and negative beam camber, pier shafts, and columns).
- Concrete pier column or cap with significant structural cracking that is supporting a fracture critical bridge or fracture critical component.
- Falling concrete or concrete that is delaminated or partially detached and anticipated to fall, presenting a safety hazard to under-passing motorists and/or pedestrians.
- Bearing seats that are severely deteriorated or undermined.
- Sidewalk structural supports or walking surface with damage or deterioration presenting a hazardous condition to pedestrians.
- Substructure units with severe scour and undermining of the substructure foundation causing instability.

## Steel

The following deficiencies represent examples of critical findings for steel:

- Steel members with deteriorated areas that have failed in buckling, crippling, more than 10% of the connectors in a connection are missing, etc., or which makes failure likely in the near future.
- Secondary structural members (diaphragms, bracing, etc.) with extensive section loss.
- Fracture critical members subjected to impact damage including gouging or tearing, perpendicular stress cracks in either the base metal or weld metal, parallel stress cracks resulting from out-of-plane distortions or poor weld details, and severe corrosion in girder flanges, webs, in truss members, or in gusset plates.
- Primary structural members with collision damage that compromises the structural capacity (including fractures, large gouges, significant twisting/kinking of beams, and section loss to truss compression members producing member buckling or severe flexural cracking).
- Primary structural member (non-FCM member) with a completely fractured tension member due to fatigue or vehicular collision.
- Pin and hanger systems in fracture critical members with severe deterioration or severe accumulation of debris or rust packing.
- Bottom flange cover plates with cracked welds at the end of a partial length welded cover plate for a steel multi-girder or steel floorbeam.
- Substructure units with severe scour and undermining of the substructure foundation causing instability.

## Roadside Hardware or Safety Features

The following deficiencies represent examples of critical findings for traffic safety features:

- Bridge railing (bridge parapets, median barriers, or structure-mounted guardrail) with damage or deterioration that may prevent containment and/or redirection of errant vehicles traveling at the posted speed limit.
- Pedestrian railing that is missing or detached, allowing a pedestrian to fall off the structure.
- Guardrail connections to bridge railing, concrete barrier rebar, or guardrail that is detached and in close proximity or projecting into traffic with potential for impact.

## Signs and Lighting

The following deficiencies represent examples of critical findings for signs and lighting:

- Load posting or vertical clearance signs that are missing, damaged, improperly located, or visually obstructed including relevant advance warning signs.
- Signs, traffic signals, or strain poles presenting a safety hazard to passing motorists and/or pedestrians due to extensively damaged, split or buckled sections, or with cracked welds at either pole/base connections or

member/member connections.

- Sign, traffic signal, or strain pole 4-bolt base plate connections with one or more loose nuts presenting a safety hazard to passing motorists and/or pedestrians.
- Signs with deteriorated or missing panel connectors, allowing sign to "flop" under wind loading that present a safety hazard to passing motorists and/or pedestrians.
- Lighting fixtures with split sections, buckled sections, significant section loss, and/or cracked welds at the pole/base connection that present a safety hazard to passing motorists and/or pedestrians.

### Other

The following deficiencies represent other examples of critical findings:

- Expansion joints that are deteriorated, damaged, or loose which may present a safety hazard to passing traffic.
- Rocker bearings that are critically tilted either exceeding the acceptable amount of tilt or bearing on the outer one-quarter width of the rocker.
- Excessive debris and/or sediment buildup at the hydraulic opening for scour critical bridges or other bridges with unknown foundations.

### 4.5.4

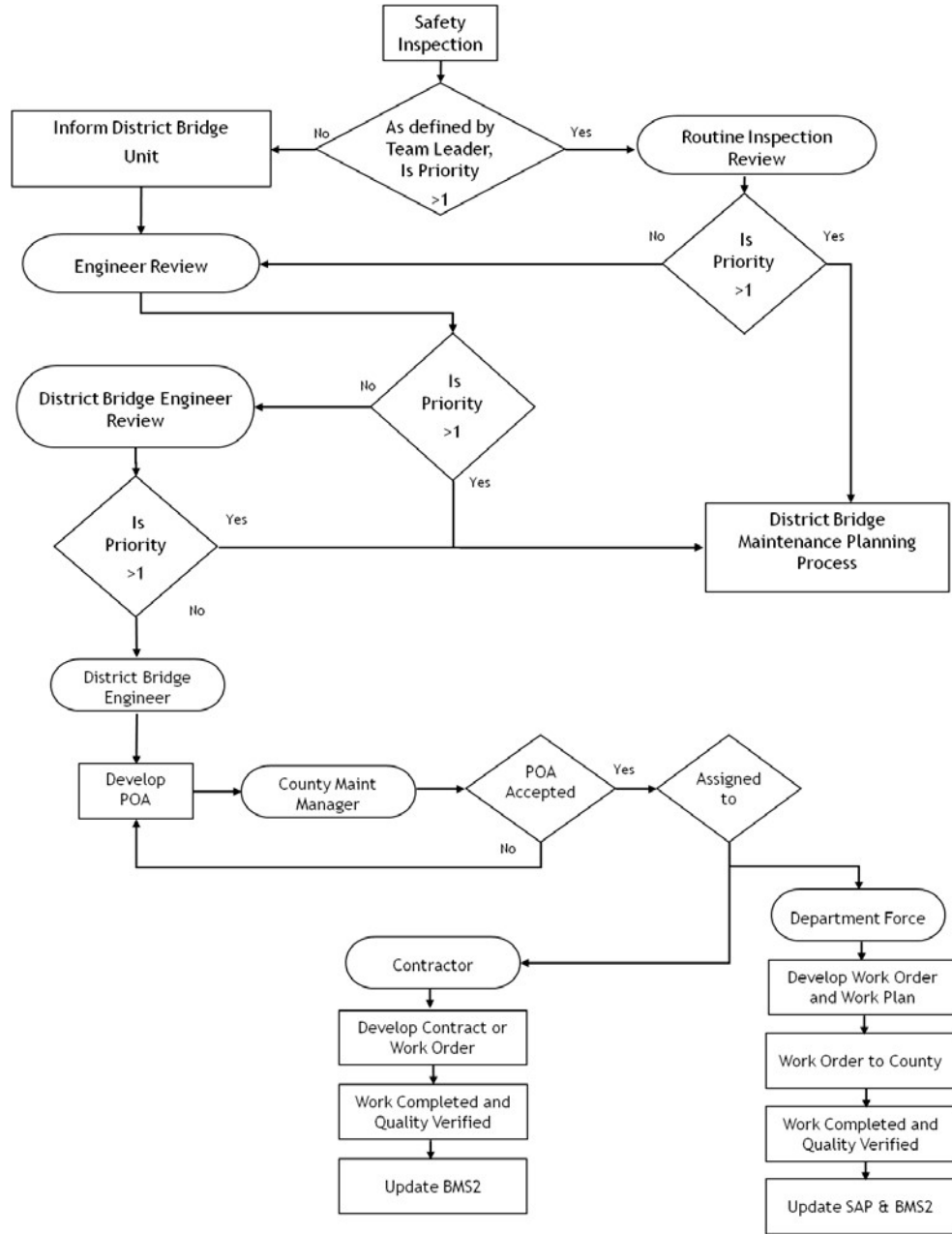
#### Example Plans of Action

As previously mentioned, a statewide or Federal agency wide procedure must be established to assure that critical findings are addressed in a timely manner. The appropriate actions to be used for repair or mitigation of the critical finding must be quickly identified and efficiently carried out. The FHWA must be periodically notified of the actions that have been taken to resolve or monitor critical findings. It is the responsibility of Bridge Owners to implement procedures for addressing critical deficiencies including:

- Immediate critical deficiency reporting steps
- Emergency notification of police and the public
- Rapid evaluation of the deficiencies
- Rapid implementation of corrective or protective actions
- A tracking system to ensure adequate follow-up
- Provisions for identifying other bridges with similar structural details for follow-up inspections

Some agencies have very strict timeframes (3 to 7 *calendar* days) for developing and accepting plans of action. For circumstances involving immediate attention or a more detailed solution, it may be necessary to begin addressing the critical finding (through permanent or temporary work) prior to the 100% development and acceptance of the plan of action. Example plans of action are given below for Pennsylvania DOT (Figure 4.5.3) and Washington State DOT (Figure 4.5.4).





**Figure 4.5.3** Pennsylvania DOT Critical and High Priority Maintenance Items – Flowchart for Plan of Action

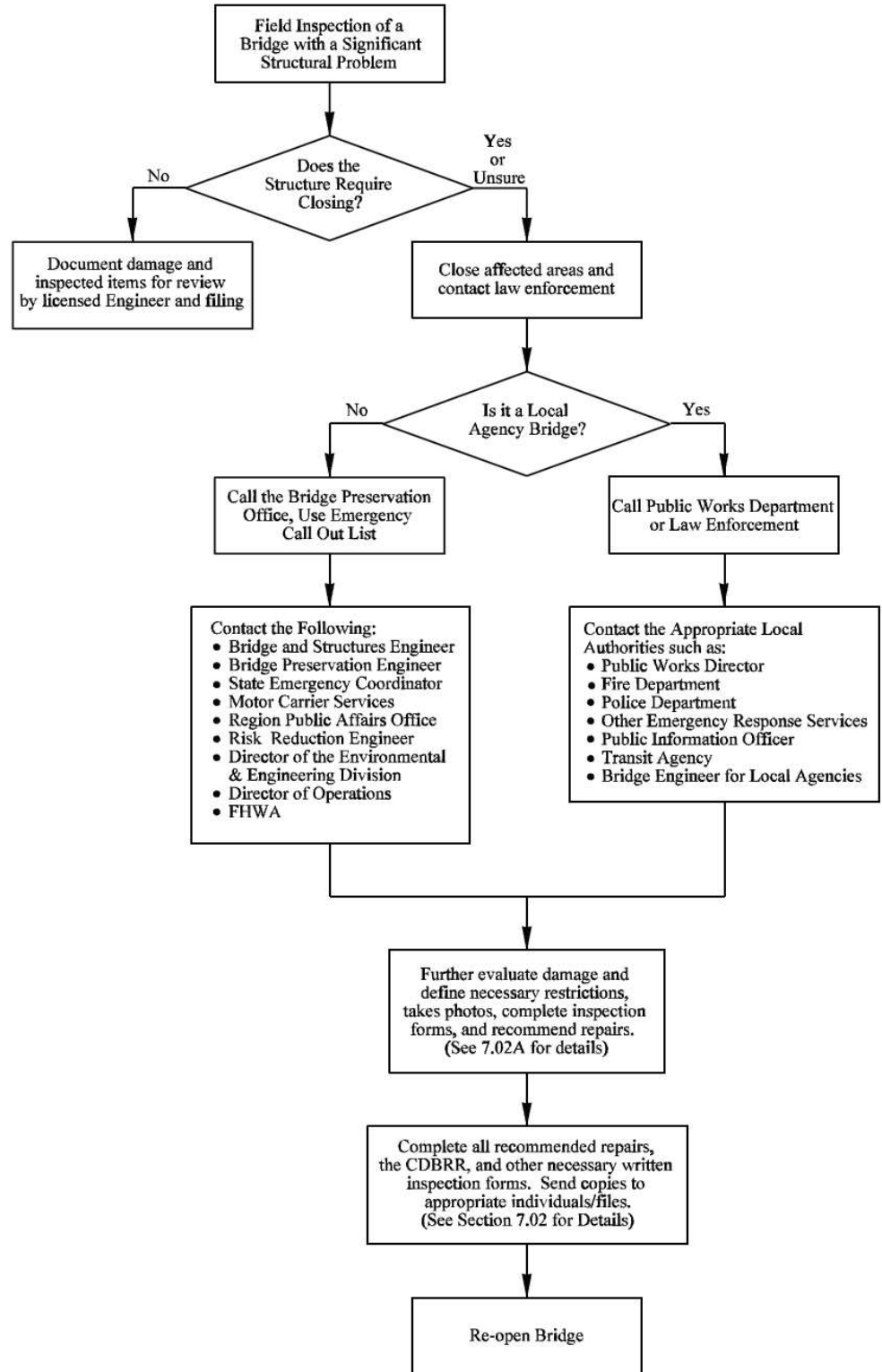


Figure 4.5.4 Washington State DOT Flowchart for Field Inspection Procedure

After the plan of action has been accepted, recommended repair work will then be performed and completed within a few days up to several weeks, depending on the individual agency's regulations. A post-repair report will be generated documenting all necessary work done to address the critical finding and the date of completion. A follow-up inspection will also be conducted to assess the condition of the repairs. The FHWA will be notified of the repair and post-repair progress.

# Table of Contents

## Chapter 4 Bridge Inspection Reporting

---

|       |  |        |
|-------|--|--------|
| 4.6   | The Inspection Report.....   | 4.6.1  |
| 4.6.1 | Introduction.....  | 4.6.1  |
| 4.6.2 | Basic Components of a Comprehensive In-Depth Bridge<br>Inspection Report ..... | 4.6.1  |
|       | Table of Contents .....  | 4.6.1  |
|       | Location Map .....   | 4.6.1  |
|       | Bridge Description and History.....  | 4.6.1  |
|       | Design Data .....  | 4.6.2  |
|       | Construction Data .....  | 4.6.2  |
|       | Service Data.....  | 4.6.2  |
|       | Executive Summary.....   | 4.6.2  |
|       | Inspection Procedures.....   | 4.6.3  |
|       | Inspection Results.....  | 4.6.3  |
|       | Load Rating Summary.....   | 4.6.4  |
|       | Conclusions and Recommendations.....   | 4.6.4  |
|       | Report Appendices .....  | 4.6.5  |
|       | Photographs.....   | 4.6.5  |
|       | Drawings and Sketches .....  | 4.6.7  |
|       | Inspection Forms.....  | 4.6.7  |
|       | Load Capacity Analysis .....   | 4.6.7  |
|       | Field Inspection Notes .....   | 4.6.7  |
|       | Underwater Inspection Report .....   | 4.6.7  |
|       | Material Testing Results .....   | 4.6.7  |
| 4.6.3 | Basic Components of a Comprehensive Routine<br>Inspection Report .....         | 4.6.8  |
|       | Location Map .....   | 4.6.8  |
|       | Inspection Procedures.....   | 4.6.8  |
|       | Inspection Results.....  | 4.6.8  |
|       | Load Rating Summary.....   | 4.6.9  |
|       | Conclusions .....  | 4.6.9  |
|       | Recommendations .....  | 4.6.9  |
|       | Report Appendices .....  | 4.6.10 |
|       | Photographs.....   | 4.6.10 |
|       | Drawings and Sketches .....  | 4.6.11 |
|       | Inspection Forms.....  | 4.6.11 |
|       | Load Capacity Analysis .....   | 4.6.11 |
|       | Field Inspection Notes .....   | 4.6.11 |
|       | Underwater Inspection Report .....   | 4.6.11 |

|       |  |        |
|-------|--|--------|
| 4.6.4 | Importance of the Inspection Report..... | 4.6.12 |
|       | Source of Information.....               | 4.6.12 |
|       | Legal Document .....                     | 4.6.12 |
|       | Critical Findings .....                  | 4.6.12 |
|       | Maintenance .....                        | 4.6.12 |
|       | Load Rating Analysis .....               | 4.6.13 |
|       | Bridge Management .....                  | 4.6.13 |
| 4.6.5 | Quality .....                            | 4.6.13 |

# Topic 4.6 The Inspection Report

## 4.6.1

### **Introduction**

The purpose of the bridge inspection reporting system is to have trained and experienced personnel record objective observations of all elements of a bridge and to make logical deductions and conclusions from their observations.

The bridge inspection report represents a systematic inventory of the current or existing condition of all bridge members and their possible future weaknesses. Moreover, bridge reports form the basis of quantifying the manpower, equipment, materials, and funds that are necessary to maintain the integrity of the structure.

A bridge inspection is not complete until an inspection report is finalized. The bridge inspection report documents all signs of distress and deterioration with sufficient precision so that future inspectors can readily make a comparison of condition. Bridge owners normally set the format to be used when preparing a bridge inspection report. A complete inspection report contains several parts, as outlined in this topic. A sample bridge inspection report is presented in Appendix A. Inspection reports are prepared for special inspections, which are conducted for checking a specific item where a problem or change may be anticipated. Even if no changes are evident, reports are still generated for each type of bridge inspection. Some bridge owners also request a special bridge inspection and report when planning a major rehabilitation.

## 4.6.2

### **Basic Components of a Comprehensive In-Depth Bridge Inspection Report**

#### **Table of Contents**

The table of contents presents the general headings and topics of the inspection report in an orderly manner so that individual sections of the report can be found with ease. It generally follows the title page, and individual sections are listed with their corresponding starting page number.

#### **Location Map**

A map is normally included with a scale large enough to positively locate the structure. The bridge is clearly marked and labeled, and the map has a north arrow to aid with orientation. Some agencies may choose to use GPS coordinates or latitude/ longitude descriptions.

#### **Bridge Description and History**

The bridge description and history section of the report contains all pertinent data concerning the design, construction, and service of the bridge. The type of superstructure will generally be given first, followed by the type of abutments and piers or bents, along with their foundations. If data is available, indicate the type of foundation soil, maximum bearing pressures, and deep foundation capacities. The type of deck is also indicated.

The history of the bridge is from a structural standpoint and is developed from information obtained from design, construction and rehabilitation plans, previous inspection reports, maintenance records, discussions with maintenance crews and



local residents, and any other available source that offers pertinent information. Typical items included in the history narrative are:

- Historical flood frequencies and high water marks
- Maintenance measures and repairs
- Chronological record of conditions (in order to help determine a rate of deterioration of all bridge components and the channel). The agency establishes criteria for the number of bridge inspections kept on file.
- Reference drawings
- Photos, which would consist of a typical approach photograph showing the approach roadway, bridge and any load restriction signs, as well as an elevation/profile photograph showing upstream/downstream of the bridge. Other photographs, such as those conveying the condition of the bridge and its components, would be found in the Appendix or in the Inspection Results section of the inspection report.

### **Design Data**

The design information includes a description of the following:

- |                                |                                  |
|--------------------------------|----------------------------------|
| ➤ Skew angle                   | ➤ Railing and median             |
| ➤ Number and length of spans   | ➤ Year constructed/reconstructed |
| ➤ Span type and material       | ➤ Number of traffic lanes        |
| ➤ Total length                 | ➤ Design live loading            |
| ➤ Bridge width                 | ➤ Waterway                       |
| ➤ Deck structure type          | ➤ Other features intersected     |
| ➤ Wearing surface              | ➤ Clearances                     |
| ➤ Deck protection and membrane | ➤ Encroachments                  |
| ➤ Sidewalks                    | ➤ Alignment                      |

### **Construction Data**

The construction history of the bridge includes the date it was originally built, as well as the dates and descriptions of any repairs or reconstruction projects. State what plans are available, where they are filed, and whether they are “design”, “as-built”, or “rehabilitation” drawings.

### **Service Data**

The average daily traffic (ADT) count and the average daily truck traffic (ADTT) count are included, along with the date of record. This information is updated approximately every five years. Other service data to consider includes the year of ADT and ADTT, facility carried, functional classification, and bypass detour length and map. In addition, environmental conditions that may have an effect on the bridge, such as salt spray, industrial gases, bird droppings, and ship and railroad traffic, are noted in the report.

### **Executive Summary**

The executive summary is a narrative presentation summarizing the inspection and analysis findings in regard to the qualitative condition and the load capacity of the bridge, along with an overview of recommendations. A typical executive summary identifies the bridge (e.g., name, number, and location) and the date of inspection. The executive summary presents any high priority repair items.

## Inspection Procedures

The procedures used to inspect the bridge are documented in the inspection report. In most instances, it is advantageous to inspect structures in the same sequence as the load path (i.e., the deck first, then the superstructure, and finally the substructure). This manual is organized and presented for that sequence.

Many inspections cannot follow this sequence due to traffic and lane-closure restrictions. It is useful to document whatever sequence was used during the inspection. This information will be useful in planning future inspections and will also serve as a checklist to make sure that all elements and components were inspected. The following information is typically included:

- Equipment required (e.g., hammers and plumb bobs)
- Access equipment (e.g., rigging, ladders, and free climbing)
- Access vehicles (e.g., inspection cranes and bucket trucks)
- Traffic restrictions (e.g., lane closures, flagmen, and hours of operation)
- Permits required (e.g., railroad and Coast Guard)
- Inspection methods (e.g., visual, physical or advanced)
- Personnel (e.g., by name and classification)
- Special equipment (e.g., material testing and underwater inspection)
- Deviations from “hands-on” inspection of all areas
- Time required for inspection
- Channel profiles, cross sections and scour criticality

When structure plans are not in the bridge records and a load rating has not been calculated, it may be necessary to obtain field measurements to assist in the calculation of the load capacity of the structure.

## Inspection Results

Provide narrative descriptions of the conditions both quantitative and qualitative, indicating the locations and the extent of the affected areas. Use agency-approved forms consistent with similar inspections. Note all signs of distress, failure, or defects with sufficient precision so that a deterioration rate can be determined. This is very important for determining estimated remaining life and an optimal preservation strategy. Take photographs in the field to show deficiencies and cross reference in the report or on forms where deficiencies are noted. Supplement written notes with sketches and photos to show location and physical characteristics of deficiencies, including a known object in the photograph for scale reference.

Note any load, speed, or traffic restrictions on the bridge. Indicate if the signs are missing or damaged. Take approach roadway photograph to confirm placement of load posting signs that includes the approach roadway, bridge and sign. Check for advanced warning signs. Include information about high water marks and unusual loadings. Note the weather conditions such as temperature, rain, or snow. Note all work or repairs to the bridge since last inspection. Verify or obtain new dimensions when improvement work has altered the structure. New streambed profiles and cross sections are taken to detect scour, channel migration, or channel aggradation and degradation. Note any channel restrictions (e.g. debris) that could impact stream flow and increase scour potential. State the seriousness and amount of all deficiencies at the bridge site.

### **Load Rating Summary**

A summary of any load capacity rating analysis that has been performed is included in the report. The summary is presented in a table or chart. Governing load ratings are shown for both inventory and operating levels for all types of loadings used in the analysis. Identify the governing member for each rating. The governing member is the one that has the lowest capacity for a given type of loading.

For example, in a girder-floorbeam-stringer structure, Stringer three in Bay five may have the lowest capacity for carrying HS20 trucks, compared to all other stringers, floorbeams, or girders. The HS20 inventory and operating ratings for this stringer is reported, and it would be identified as the governing member.

### **Conclusions and Recommendations**

A good inspection report explains in detail the type, severity and extent of any deficiency found on the bridge and points out any deviations or modifications that are contrary to the “as-built” construction plans. The depth of the report is consistent with the importance of the deficiencies. Not all deficiencies are of equal importance. For example, a crack in a prestressed concrete box beam which allows water to enter the beam is much more serious than a vertical crack in an abutment backwall or a spall in a corner of a slopewall.

The inspector’s experience and judgment are called upon when interpreting inspection results and arriving at reasonable and practical conclusions. Improper and misinformed conclusions will lead to improper recommendations. The inspector may need to play the role of a detective to conclude why, how, or when certain deficiencies occurred. Seek advice from more experienced personnel when you cannot confidently interpret the inspection findings.

The recommendations made by the inspector constitute the “focal point” of the operation of inspecting, recording, and reporting. The inspector reviews previous inspection recommendations and identifies any recommendations that have not been addressed, particularly if urgent. A thorough, well-documented inspection is essential for making informed and practical recommendations to correct or preclude bridge deficiencies.

All recommendations for preservation work, load rating, postings, and further inspection are included in this portion of the inspection report. Carefully consider the benefits to be derived from completing recommended work and the consequences if the work is not completed. List, in order of greatest urgency, any work that is necessary to maintain structural integrity and public safety. Recommendations concerning work are typically classified between three to five distinct prioritization levels, which range from the most severe or significant (critical) to a maintenance item that is considered routine or may only require monitoring (non-critical). The specific prioritization levels are set forth by each bridge-owning agency. Examples of agency priority maintenance procedures are listed in Topic 4.5.2.

The inspector decides whether a deficiency is a critical finding and needs immediate action using agency procedures. Usually this is easily determined, but occasionally the experience and judgment of a professional engineer may be required to reach a proper decision. A large hole through the deck of a bridge obviously needs attention, and a recommendation for immediate action is in order. Communicate the critical finding immediately and document actions taken in the

report. By contrast, a slightly deteriorated bridge bearing may not be critical. A condition such as this would appropriately call for a recommendation for a preservation action.

Typically, most work recommendations submitted by the bridge inspector will be in the category of non-critical work. The recommended work is carefully described in the report along with a cost estimate.

If not already described in the executive summary, the conclusions and recommendations section of the report summarizes the following:

- Overall condition
- Major deficiencies
- Load-carrying capacity
- Recommendations for:
  - Further inspection
  - Maintenance
  - Repairs
  - Painting
  - Posting
  - Rehabilitation
  - Replacement

Some state and local agencies designate separate personnel, not the inspector in the field, to prepare recommendations and cost estimates.

## Report Appendices

To achieve maximum effectiveness of the inspection report, the report appendices contain any back-up information used to substantiate the inspector's findings, conclusions and recommendations. Typically, the appendices include photographs, drawings and sketches, and inspection forms (see Topic 4.4 for record keeping and documentation). Appendices may also include copies of any field notes used and specialist reports (e.g., underwater, nondestructive evaluation (NDE), and survey), or these documents may be referenced in the report. A load capacity rating analysis of the structure may also be incorporated into the report appendices. It is important to have the inspection report and all supplemental information, including report appendices, accurate with clear and concise descriptions or explanations.

### Photographs

Photographs are a great asset to anyone reviewing reports on bridge structures. It is recommended that pictures be taken of any problem areas. Take pictures even if you think you can explain it completely in writing. It is better to take several photographs that may be considered unessential than to omit a photograph that could cause misinterpretation or misunderstanding of the report. At least two general photographs of every structure are provided in the appendix. One of these depicts the structure from the roadway, while the other photo is a view of the side elevation (see Figures 4.6.1 and 4.6.2). Captions are provided for each photograph. Photographs are numbered so that they can be referred to in the body of the report. Sketches may also be a substitute for missing as-built plans.



**Figure 4.6.1** Near Approach - Toward Bridge



**Figure 4.6.2** Downstream Elevation

### **Drawings and Sketches**

Sketches and drawings needed to illustrate and clarify conditions of structural elements or serve as as-built plans are included or referenced. Sketches may be able to convey information not readily identified in a photograph (ie. remaining web thickness). Original drawings are very helpful during future investigations with determining the progression of defects and to help determine any changes and their magnitude. Drafting-quality plans and sketches, sufficient to indicate the layout of the bridge and bridge site, may be included as an appendix.

Some reports combine photographs and sketches or text boxes together to accurately describe and document a particular deficiency.

### **Inspection Forms**

The inspection forms contain the actual field notes, as well as the numerical condition and appraisal ratings by the inspector. The inspection forms are normally signed by the inspection team leader. A complete SI&A form or equivalent is included in the appendix. Compare previous inspection forms to current conditions for inventory data accuracy.

### **Load Capacity Analysis**

A load rating analysis is performed on the structure to determine the load-carrying capacity of the bridge. It includes the investigation of primary load-carrying members of the bridge. Such analysis is normally performed by engineers in the office, not by the inspector. Also, not all inspections require a new load rating analysis. A new load rating analysis is performed if the condition of the primary members has changed considerably since the last inspection. The report also includes recommendations for a new load rating analysis when maintenance or improvement work, change in strength of members, or dead load has altered the condition or capacity of the structure.

### **Field Inspection Notes**

Include the original notes taken by the inspectors in the field or photocopies thereof in the appendix section of the report. The original field notes are source documents and as such are typically included in the bridge record.

### **Underwater Inspection Report**

If an underwater inspection of the substructure has been performed, a separate report is usually prepared by the dive team. If applicable, include the underwater inspection report in the appendix or cross-reference the location of the report.

### **Material Testing Results**

Material testing may be performed on a structure in order to determine the strength and properties of an unknown or suspect material. Include the testing lab's report in the appendix.



### 4.6.3

## **Basic Components of a Comprehensive Routine Inspection Report**

### **Location Map**

A map with a scale may be included to help positively locate the structure. Some agencies may choose to use GPS coordinates or latitude/longitude descriptions to supplement or replace the location map.

### **Inspection Procedures**

The procedures used to inspect the bridge may be documented in the inspection report. For inspection reports that include the inspection procedures, it is advantageous to inspect structures in the same sequence as the load path (i.e., the deck first, then the superstructure, and finally the substructure).

As with in-depth inspections, some routine inspections cannot follow this sequence due to traffic and lane-closure restrictions. Therefore, it is useful to document whatever sequence was used during the inspection. This information will be useful in planning future inspections and will also serve as a checklist to make sure that all elements and components were inspected. The following information is typically included:

- Equipment required (e.g., hammers and plumb bobs)
- Access equipment (e.g., rigging, ladders, and free climbing)
- Access vehicles (e.g., inspection cranes and bucket trucks)
- Traffic restrictions (e.g., lane closures, flagmen, and hours of operation)
- Permits required (e.g., railroad and Coast Guard)
- Inspection methods (e.g., visual, physical or advanced)
- Personnel (e.g., by name and classification)
- Special equipment (e.g., material testing and underwater inspection)
- Deviations from “hands-on” inspection of all areas
- Time required for inspection
- Channel profiles, cross sections and scour criticality

When structure plans are not in the bridge records and a load rating has not been calculated, it may be necessary to obtain field measurements to assist in the calculation of the load capacity of the structure.

### **Inspection Results**

The results of the inspection are documented within the inspection forms. Narrative descriptions of the conditions are typically not included for routine inspection reports. As with in-depth inspections, use agency-approved forms consistent with similar inspections. Note all signs of distress, failure, or defects with sufficient precision so that a deterioration rate can be determined. This is very important for determining estimated remaining life and an optimal preservation strategy. Take photographs in the field to show deficiencies and cross reference in the report or on forms where deficiencies are noted. Supplement written notes with sketches and photos to show location and physical characteristics of deficiencies, including a known object in the photograph for scale reference.



Note any load, speed, or traffic restrictions on the bridge. Indicate if the signs are missing or damaged. Take approach roadway photograph to confirm placement of load posting signs that includes the approach roadway, bridge and sign. Check for advanced warning signs. Include information about high water marks and unusual loadings. Note the weather conditions such as temperature, rain, or snow. Note all work or repairs to the bridge since last inspection. Verify or obtain new dimensions when improvement work has altered the structure. New streambed profiles and cross sections are taken to detect scour, channel migration, or channel aggradation and degradation. Note any channel restrictions (e.g. debris) that could impact stream flow and increase scour potential. State the seriousness and amount of all deficiencies at the bridge site.

### **Load Rating Summary**

For routine inspections, a load rating may be conducted. If performed, a load rating summary is included in the report and may also be included on the inspection forms. The summary is presented in a table or chart. Governing load ratings are shown for both inventory and operating levels for all types of loadings used in the analysis. Identify the governing member for each rating. The governing member is the one that has the lowest capacity for a given type of loading.

### **Conclusions**

A routine inspection report may or may not contain conclusions of the inspection. If conclusions are included, explain in detail the type, severity and extent of any deficiency found on the bridge and point out any deviations or modifications that are contrary to the “as-built” construction plans. The depth of the report is consistent with the importance of the deficiencies. Not all deficiencies are of equal importance.

The inspector’s experience and judgment are called upon when interpreting inspection results and arriving at reasonable and practical conclusions. Improper and misinformed conclusions will lead to improper recommendations. The inspector may need to play the role of a detective to conclude why, how, or when certain deficiencies occurred. Seek advice from more experienced personnel when you cannot confidently interpret the inspection findings.

### **Recommendations**

Recommendations are made by the inspector that constitutes the “focal point” of the operation of inspecting, recording, and reporting. The inspector reviews previous inspection recommendations and identifies any recommendations that have not been addressed, particularly if urgent. A thorough, well-documented inspection is essential for making informed and practical recommendations to correct or preclude bridge deficiencies.

All recommendations for preservation work, load rating, postings, and further inspection are included in this portion of the inspection report. Carefully consider the benefits to be derived from completing recommended work and the consequences if the work is not completed. List, in order of greatest urgency, any work that is necessary to maintain structural integrity and public safety. Recommendations concerning work are typically classified between three to five distinct prioritization levels, which range from the most severe or significant (critical) to a maintenance item that is considered routine or may only require monitoring (non-critical). The specific prioritization levels are set forth by each bridge-owning agency. Examples of agency priority maintenance procedures are

listed in Topic 4.5.2.

The inspector decides whether a deficiency is a critical finding and needs immediate action using agency procedures. Usually this is easily determined, but occasionally the experience and judgment of a professional engineer may be required to reach a proper decision. A large hole through the deck of a bridge obviously needs attention, and a recommendation for immediate action is in order. Communicate the critical finding immediately and document actions taken in the report. By contrast, a slightly deteriorated bridge bearing may not be critical. A condition such as this would appropriately call for a recommendation for a preservation action.

Typically, most work recommendations submitted by the bridge inspector will be in the category of non-critical work. The recommended work is carefully described in the report along with a cost estimate.

The recommendations section of the report summarizes the following:

- Further inspection
- Maintenance
- Repairs
- Painting
- Posting
- Rehabilitation
- Replacement

Some state and local agencies designate separate personnel, not the inspector in the field, to prepare recommendations and cost estimates.

## **Report Appendices**

To achieve maximum effectiveness of the inspection report, the report appendices contain any back-up information used to substantiate the inspector's findings, conclusions (if included) and recommendations. Typically, the appendices include photographs, drawings and sketches, and inspection forms. See Topic 4.4 for record keeping and documentation. Note that for routine inspections, inspection forms comprise the report, itself. Appendices may also include copies of any field notes used and specialist reports (e.g., underwater, nondestructive evaluation (NDE), and survey), or these documents may be referenced in the report. Although typically not conducted for routine inspections, a load capacity rating analysis of the structure may also be incorporated into the report appendices if performed. It is important to have the inspection report and all supplemental information, including report appendices, accurate with clear and concise descriptions or explanations.

### **Photographs**

Photographs are a great asset to anyone reviewing reports on bridge structures. It is recommended that pictures be taken of any problem areas. Take pictures even if you think you can explain it completely in writing. It is better to take several photographs that may be considered unessential than to omit a photograph that could cause misinterpretation or misunderstanding of the report. At least two general photographs of every structure are provided in the appendix. One of these depicts the structure from the roadway, while the other photo is a view of the side

elevation (see Figures 4.6.1 and 4.6.2). Captions are provided for each photograph. Photographs are numbered so that they can be referred to in the body of the report. Sketches may also be a substitute for missing as-built plans.

### **Drawings and Sketches**

Sketches and drawings needed to illustrate and clarify conditions of structural elements or serve as as-built plans are included or referenced. Sketches may be able to convey information not readily identified in a photograph (i.e., remaining web thickness). Original drawings are very helpful during future investigations with determining the progression of defects and to help determine any changes and their magnitude. Drafting-quality plans and sketches, sufficient to indicate the layout of the bridge and bridge site, may be included as an appendix.

Some reports combine photographs and sketches or text boxes together to accurately describe and document a particular deficiency.

### **Inspection Forms**

The inspection forms comprise the actual routine inspection report and contain the field notes, as well as the numerical condition and appraisal ratings by the inspector. The inspection forms are normally signed by the inspection team leader. A complete SI&A form or equivalent is included in the appendix. Compare previous inspection forms to current conditions for inventory data accuracy.

### **Load Capacity Analysis**

A load rating analysis may or may not be performed on the structure to determine the load-carrying capacity of the bridge. For routine inspections without a load capacity analysis, the results of the previous load capacity analysis are typically included in the report. If a load capacity analysis is performed, it is normally performed by engineers in the office, not by the inspector, and represents an investigation of primary load-carrying members of the bridge. A new load rating analysis is performed if the condition of the primary members has changed considerably since the last inspection. The report also includes recommendations for a new load rating analysis when maintenance or improvement work, change in strength of members, or dead load has altered the condition or capacity of the structure.

### **Field Inspection Notes**

Include the original notes taken by the inspectors in the field or photocopies thereof in the appendix section of the report. The original field notes are source documents and as such are typically included in the bridge record.

### **Underwater Inspection Report**

If an underwater inspection of the substructure has been performed, the summary of findings of the underwater inspection report (typically prepared by the dive team) is usually included in the appendix or cross-referenced to another location of the report.

## 4.6.4

### **Importance of the Inspection Report**

#### **Source of Information**

A well-prepared report will not only provide information on existing bridge and bridge site conditions, but it also becomes an excellent reference source for future inspections, comparative analyses, and bridge study projects. Any conditions that are suspicious but unclear are reported in a factual manner, avoiding speculation. Terms such as “hazardous” or “dangerous” are subjective and are not used in the inspection report or inspection documentation that may be included in the appendix. Further action on such reports will be determined after review and consultation by experienced personnel.

#### **Legal Document**

In preparing an inspection report, keep in mind that bridge funding may be allocated or repairs designed based on this information. Furthermore, the inspection report is a legal record which may form an important element in future litigation. The language used in reports needs to be clear and concise and, in the interest of uniformity, care needs to be taken to avoid ambiguity of meaning. The information contained in reports is obtained from field investigations, supplemented by reference to “as-built” or “field-checked” plans. The source of all information contained in a report needs to be clearly stated.

Some state agencies require inspection reports to be signed, dated and sealed by a professional engineer before accepting them. Other state agencies require inspection reports to be signed and dated by the inspection team leader. The AASHTO *MBE* states (per Article 2.2) that "the components of data entered in a bridge record should be dated and include the signature of the individual responsible for the data presented." No undocumented alterations are allowed to the report once it is accepted. Some inspectors retain copies of their reports for their personal files in the interest of self-protection if there is any litigation.

#### **Critical Findings**

Critical findings are documented in the inspection report. However, the inspection report does not provide guidance for the follow-up to critical findings - the inspector does not wait for the inspection report to communicate and take action on critical findings. Instead, the follow-up to critical findings is a separate procedure that is immediately communicated with action taken on the critical findings, in accordance with the requirements of the NBIS. Agency procedures are established to assure that critical findings are addressed in a timely manner. In many instances when the critical finding exists, a plan of action is established and the deficiency is addressed prior to the formal submittal of the inspection report.

The FHWA is periodically notified of the actions taken to resolve or monitor critical findings. Advanced inspection methods for one or more elements may be recommended. The report provides information which may lead to decisions to limit the use of a bridge or close it to traffic; any bridge which the inspection has revealed to be a potential public safety concern.

#### **Maintenance**

Another purpose of the inspection report is to provide useful information about the needs and effectiveness of preservation activities. An active preservation program is vital to the long-term structural integrity of a bridge. The inspection report enables bridge preservation to be programmed more effectively through early

detection of structural deficiencies, therefore minimizing more costly future work and inconvenience to the traveling public.

### **Load Rating Analysis**

When an inspection reveals deficiencies that may affect the load-carrying capacity of the structure, the findings need to be reviewed by an engineer to determine if a revised load rating analysis is required. A new load rating analysis is performed to determine the safe load capacity for the current condition. It may then be necessary to restrict loads crossing the bridge so that its safe load capacity is not exceeded. It is important that the revised load-carrying capacity (load rating) analysis become part of the bridge record.

### **Bridge Management**

Another purpose of the inspection report is analysis by the bridge owners and the FHWA of the SI&A data. The intent of the analysis is to aid in the decisions for allocating and prioritizing funding.

Another important purpose of the inspection report is the data the report provides for use by the owner in managing the bridge asset. The data provided in the inspection report is important for the identification, prioritization, budgeting and programming of bridge preservation, improvement and replacement work. On a national level the data is used for reporting to Congress on the condition and performance of the Nation's bridges and for determining current and future estimates of funding needs. Furthermore, the data is used to: classify bridges according to serviceability, safety, and essentiality for public use; assign each a priority for replacement or rehabilitation; and determine the cost of replacing each such bridge with a comparable facility or of rehabilitating such bridge.

## **4.6.5**

### **Quality**

---

The accuracy and uniformity of information collected and recorded is vital for the management of an owner's bridges for preservation, improvement and replacement, and, most importantly, public safety. Quality cannot be taken for granted. The responsibility of ensuring quality bridge inspections rests with each bridge owner and the inspection team. Two phrases are frequently used when discussing quality; they are quality control and quality assurance.

NBIS regulations require each state to assure that systematic quality control (QC) and quality assurance (QA) procedures are being used to maintain a high degree of accuracy and consistency in the inspection program. Include periodic field review of inspection teams, periodic bridge inspection refresher training for program managers and team leaders, and independent review of inspection reports and computations.

The AASHTO *MBE* provides guidance for the implementation of appropriate quality control and quality assurance procedures. Quality control procedures include the "use of checklists to ensure uniformity and completeness, the review of reports and computations by a person other than the originating individual, and the periodic field review of inspection teams and their work." Quality assurance procedures include the "overall review of the inspection and rating program to ascertain that the results meet or exceed the standards established" by the bridge-owning agency.

Follow state-wide or agency-wide QC/QA procedures for a higher degree of accuracy and consistency in the inspection program.

See Topic 1.3 for a detailed description of quality control and quality assurance.

# Table of Contents

## Chapter 5 Bridge Mechanics

---

|       |                                  |        |
|-------|----------------------------------|--------|
| 5.1   | Bridge Mechanics .....           | 5.1.1  |
| 5.1.1 | Introduction .....               | 5.1.1  |
| 5.1.2 | Bridge Design Loadings.....      | 5.1.1  |
|       | Permanent Loads.....             | 5.1.2  |
|       | Primary Transient Loads.....     | 5.1.3  |
|       | AASHTO Truck Loadings .....      | 5.1.3  |
|       | AASHTO Lane Loadings.....        | 5.1.6  |
|       | LRFD Live Loads.....             | 5.1.6  |
|       | Alternate Military Loading.....  | 5.1.7  |
|       | Permit Vehicles .....            | 5.1.8  |
|       | Secondary Transient Loads.....   | 5.1.9  |
| 5.1.3 | Bridge Response to Loadings..... | 5.1.10 |
|       | Equilibrium .....                | 5.1.10 |
|       | Axial Forces.....                | 5.1.10 |
|       | Bending Forces .....             | 5.1.11 |
|       | Shear Forces.....                | 5.1.13 |
|       | Torsional Forces.....            | 5.1.14 |
|       | Reactions.....                   | 5.1.15 |
| 5.1.4 | Response to Loadings.....        | 5.1.16 |
|       | Force .....                      | 5.1.16 |
|       | Stress.....                      | 5.1.16 |
|       | Deformation.....                 | 5.1.16 |
|       | Strain .....                     | 5.1.16 |
|       | Elastic Deformation.....         | 5.1.17 |
|       | Plastic Deformation.....         | 5.1.17 |
|       | Creep .....                      | 5.1.17 |
|       | Thermal Effects .....            | 5.1.18 |
|       | Stress-Strain Relationship.....  | 5.1.18 |
|       | Modulus of Elasticity .....      | 5.1.18 |
|       | Overloads .....                  | 5.1.19 |
|       | Buckling .....                   | 5.1.19 |
|       | Elongation .....                 | 5.1.19 |
|       | Critical Finding.....            | 5.1.20 |
|       | Ductility and Brittleness .....  | 5.1.20 |
|       | Fatigue .....                    | 5.1.20 |
|       | Isotropy .....                   | 5.1.21 |
| 5.1.5 | Mechanics of Materials .....     | 5.1.21 |
|       | Yield Strength .....             | 5.1.21 |
|       | Tensile Strength .....           | 5.1.21 |
|       | Toughness .....                  | 5.1.21 |



|        |  |        |
|--------|--|--------|
| 5.1.6  | Bridge Movements .....                 | 5.1.21 |
|        | Live Load Deflections.....             | 5.1.21 |
|        | Thermal Movements .....                | 5.1.22 |
|        | Rotational Movements.....              | 5.1.22 |
| 5.1.7  | Design Methods.....                    | 5.1.22 |
|        | Allowable Stress Design .....          | 5.1.22 |
|        | Load Factor Design .....               | 5.1.22 |
|        | Load and Resistance Factor Design..... | 5.1.22 |
| 5.1.8  | Bridge Load Ratings.....               | 5.1.22 |
|        | Inventory Rating .....                 | 5.1.24 |
|        | Operating Rating.....                  | 5.1.24 |
|        | Permit Loading.....                    | 5.1.24 |
|        | Rating Vehicles .....                  | 5.1.24 |
|        | Bridge Posting.....                    | 5.1.26 |
| 5.1.9  | Span Classifications.....              | 5.1.27 |
|        | Simple .....                           | 5.1.28 |
|        | Continuous.....                        | 5.1.29 |
|        | Cantilever.....                        | 5.1.30 |
| 5.1.10 | Bridge Deck Interaction .....          | 5.1.31 |
|        | Non-composite.....                     | 5.1.31 |
|        | Composite .....                        | 5.1.31 |
|        | Integral .....                         | 5.1.33 |
|        | Orthotropic.....                       | 5.1.34 |
| 5.1.11 | Redundancy .....                       | 5.1.34 |
|        | Load Path Redundancy .....             | 5.1.34 |
|        | Structural Redundancy.....             | 5.1.34 |
|        | Internal Redundancy .....              | 5.1.35 |
|        | Nonredundant Configuration .....       | 5.1.35 |
| 5.1.12 | Foundations .....                      | 5.1.35 |
|        | Spread Footings .....                  | 5.1.35 |
|        | Deep Foundations .....                 | 5.1.35 |

This page intentionally left blank.

**Basic Equations of Bridge Mechanics**

$$f_a = \frac{P}{A} \text{ (Page 5.1.11)}$$

$$\sigma = \frac{F}{A} \text{ (Page 5.1.16)}$$

$$f_b = \frac{Mc}{I} \text{ (Page 5.1.13)}$$

$$\varepsilon = \frac{\Delta L}{L} \text{ (Page 5.1.17)}$$

$$f_v = \frac{V}{A_w} \text{ (Page 5.1.14)}$$

$$E = \frac{\sigma}{\varepsilon} \text{ (Page 5.1.18)}$$

|        |  |                              |
|--------|--|------------------------------|
| where: | A = area; cross-sectional area                                       | Common units:                |
|        | A <sub>w</sub> = area of web   | p = pounds                   |
|        | c = distance from neutral axis to extreme fiber (or surface) of beam | in = inches                  |
|        | E = modulus of elasticity  | ft = feet = 12 inches        |
|        | F = force; axial force   | k = kip = 1000 pounds        |
|        | f <sub>a</sub> = axial stress  | psi = pounds per square inch |
|        | f <sub>b</sub> = bending stress                                      | ksi = kips per square inch   |
|        | f <sub>v</sub> = shear stress  |                              |
|        | I = moment of inertia  |                              |
|        | L = original length  |                              |
|        | M = applied moment   |                              |
|        | S = stress   |                              |
|        | V = vertical shear force due to external loads                       |                              |
|        | ΔL = change in length  |                              |
|        | ε = strain   |                              |

$$\text{Bridge Rating Factor (RF)} = \frac{C - A_1 D}{A_2 L(1 + I)} \text{ (Page 5.1.23)}$$

$$\text{Bridge Rating Factor (RF)} = \frac{C - (\gamma_{DC})(DC) - (\gamma_{DW})(DW) \pm (\gamma_P)(P)}{(\gamma_L)(LL + IM)} \text{ (Page 5.1.23)}$$

# Chapter 5

## Bridge Mechanics

### Topic 5.1 Bridge Mechanics

#### 5.1.1

##### Introduction

Mechanics is the branch of physical science that deals with energy and forces and their relation to the equilibrium, deformation, or motion of bodies. The bridge inspector is primarily concerned with statics, or the branch of mechanics dealing with solid bodies at rest and with forces in equilibrium.

The two most important reasons for a bridge inspector to study bridge mechanics are:

- To understand how bridge members function
- To recognize the impact a defect or deterioration may have on the load-carrying capacity of a bridge component or element

While this topic presents the basic principles of bridge mechanics, the references listed in the bibliography should be referred to for a more complete presentation of this subject.

#### 5.1.2

##### Bridge Design Loadings

A bridge is designed to carry or resist design loadings in a safe and economical manner. Loads may be concentrated or distributed depending on the way in which they are applied to the structure.

A concentrated load, or point load, is applied at a single location or over a very small area. Vehicle truck loads are normally considered concentrated loads.

A distributed load is applied to all or part of the member, and the amount of load per unit of length is generally constant. The weight of superstructures, bridge decks, wearing surfaces, and bridge parapets produce distributed loads. Secondary loads, such as wind, stream flow, earth cover and ice, are also usually distributed loads.

Highway bridge design loads are established by the American Association of State Highway and Transportation Officials (AASHTO). For many decades, the primary bridge design code in the United States was the AASHTO *Standard Specifications for Highway Bridges (Specifications)*, as supplemented by agency criteria as applicable.

During the 1990's AASHTO developed and approved a new bridge design code, entitled *AASHTO LRFD Bridge Design Specifications*. It is based upon the principles of Load and Resistance Factor Design (LRFD), as described in Topic 5.1.7.

Bridge design loadings can be divided into two principal categories:

- Permanent loads
- Transient loads

### Permanent Loads

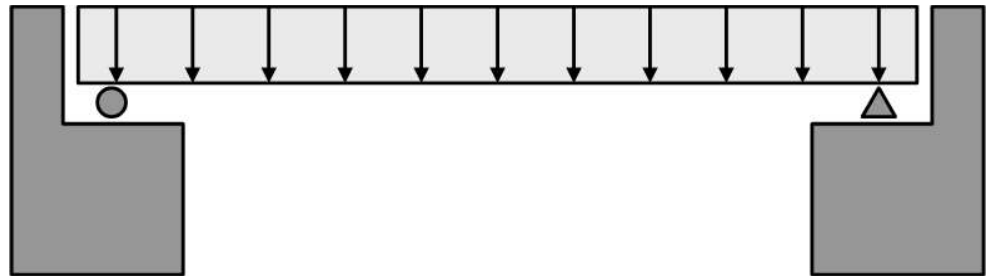
Permanent loads are loads and forces that are constant for the life of the structure. They consist of the weight of the materials used to build the bridge (see Figure 5.1.1). Permanent load includes both the self-weight of structural members and other permanent external loads. They do not move and do not change unless the bridge is modified. Permanent loads can be broken down into two groups, dead loads and earth loads.

Dead loads are a static load due to the weight of the structure itself. They include both the self-weight of the structural members and other permanent loads. Any feature may or may not contribute to the strength of the structure. Those features that may contribute to the strength of the structure include girders, floorbeams, trusses, and decks. Features that may not contribute to the strength of the bridge include median barriers, parapets, railings and utilities. Earth loads are permanent loads and are considered in the design of structures such as retaining walls and abutments. Earth pressure is a horizontal load which can be very large and it tends to cause abutments to slide and/or tilt forward. Earth surcharge is a vertical load that can increase the amount of horizontal load and is caused by the weight of the earth.

**Example of self-weight:** A 20-foot long beam weighs 50 pounds per linear foot. The total weight of the beam is 1000 pounds. This weight is called the self-weight of the beam.

**Example of an external permanent load:** If a utility such as a water line is permanently attached to the beam in the previous example, then the weight of the water line is an external permanent load. The weight of the water line plus the self weight of the beam comprises the total permanent load.

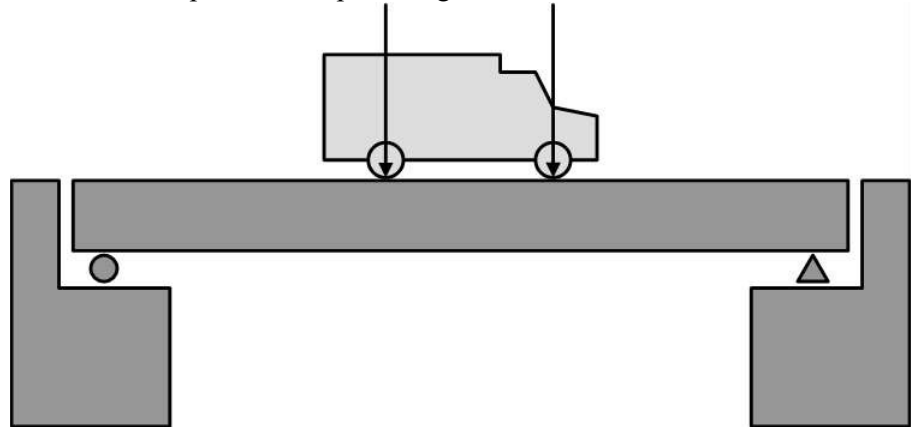
Total permanent load on a structure may change during the life of the bridge due to additions such as deck overlays, parapets, utility lines, and inspection catwalks.



**Figure 5.1.1** Permanent Load on a Bridge

**Primary Transient Loads** A transient load is a temporary load and force that is applied to a structure which changes over time. In bridge applications, transient live loads are moving vehicular or pedestrian loads (see Figure 5.1.2). Standard AASHTO vehicle live loads do not represent actual vehicles, but it does provide a good approximation for bridge design and rating. AASHTO has designated standard pedestrian loads for design of sidewalks and other pedestrian structures.

To account for the affects of speed, vibration, and momentum, truck live loads are typically increased for vehicular dynamic load allowance. Vehicular dynamic load allowance is expressed as a percentage of the static truck live load effects.



**Figure 5.1.2** Vehicle Transient Load on a Bridge

### AASHTO Truck Loadings

Standard vehicle live loads have been established by AASHTO for use in bridge design and rating. There are two basic types of standard truck loadings described in the current *AASHTO Specifications*. A third type of loading is used for AASHTO Load and Resistance Factor Design and Rating.

The first type is a single unit vehicle with two axles spaced at 14 feet and designated as a highway truck or “H” truck (see Figure 5.1.3). The weight of the front axle is 20% of the gross vehicle weight, while the weight of the rear axle is 80% of the gross vehicle weight. The “H” designation is followed by the gross tonnage of the particular design vehicle. The AASHTO LRFD design vehicular live load, designated HL-93, is a modified version of the HS-20 highway loadings from the *AASHTO Standard Specifications*.

**Example of an H truck loading:** H20-35 indicates a 20 ton vehicle with a front axle weighing 4 tons, a rear axle weighing 16 tons, and the two axles spaced 14 feet apart. This standard truck loading was first published in 1935. The 1935 truck loading used a train of trucks that imitated the railroad industry’s standards.

As trucks grew heavier during World War II, AASHTO developed the new concept of hypothetical trucks. These fictitious trucks are used only for design and do not resemble any real truck on the road. The loading is now performed by placing one truck, per lane, per span. The truck is moved along the span to determine the point where it produces the maximum shear and moment. The current designation is H20-44 published in 1944.

The second type of standard truck loading is a two unit, three axle vehicle

comprised of a highway tractor with a semi-trailer. It is designated as a highway semi-trailer truck or “HS” truck (see Figure 5.1.4).

The tractor weight and wheel spacing is identical to the H truck loading. The semi-trailer axle weight is equal to the weight of the rear tractor axle, and its spacing from the rear tractor axle can vary from 14 to 30 feet. The “HS” designation is followed by a number indicating the gross weight in tons of the tractor only.

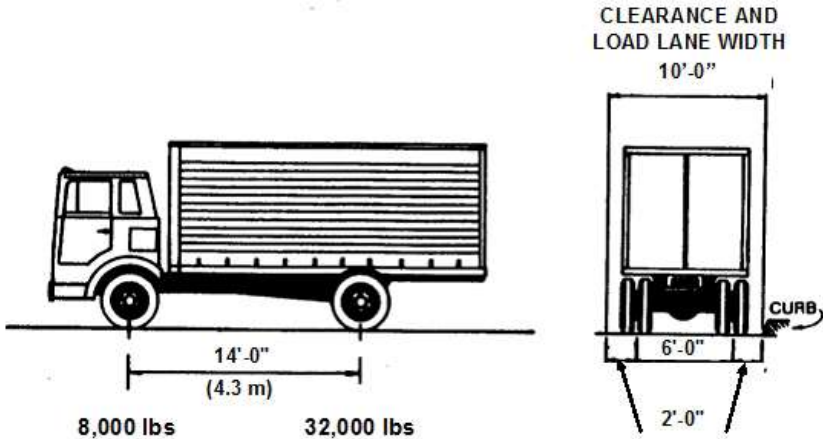
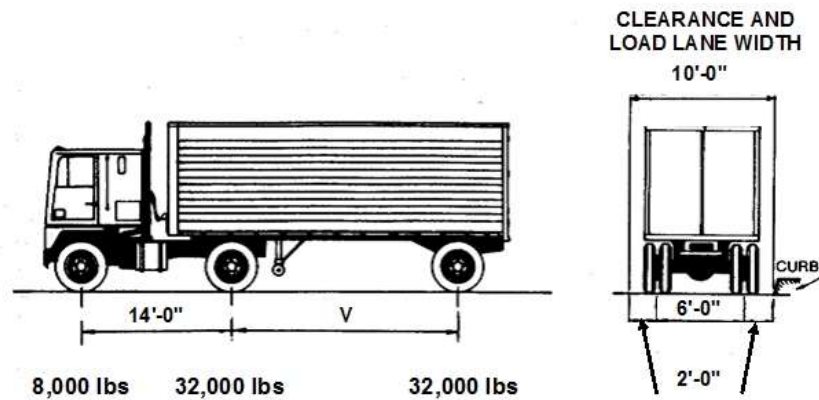


Figure 5.1.3 AASHTO H20 Truck





**Figure 5.1.4** AASHTO HS20 Truck

**Example of an HS truck loading:** HS20-44 indicates a vehicle with a front tractor axle weighing 4 tons, a rear tractor axle weighing 16 tons, and a semi-trailer axle weighing 16 tons. The tractor portion alone weighs 20 tons, but the gross vehicle weight is 36 tons. This standard truck loading was first published in 1944.

In specifications prior to 1944, a standard loading of H15 was used. In 1944, the policy of affixing the publication year of design loadings was adopted. In specifications prior to 1965, the HS20-44 loading was designated as H20-S16-44, with the S16 identifying the gross axle weight of the semi-trailer in tons.

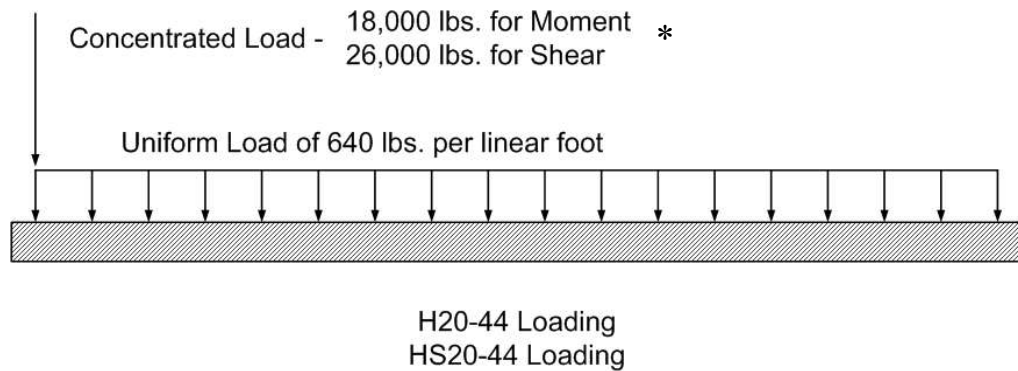
The H and HS vehicles do not represent actual vehicles, but can be considered as “umbrella” loads. The wheel spacings, weight distributions, and clearance of the Standard Design Vehicles were developed to give a simpler method of analysis, based on a good approximation of actual live loads. These loads are used for the design of bridge members. Depending on such items as highway classification, truck usage and span classification, for example, an appropriate design load is

chosen to determine the most economical member. Bridge posting is determined by performing a load rating analysis using the current member condition of an in-service bridge. Various rating methods will be discussed further in Topic 5.1.8.

### AASHTO Lane Loadings

In addition to the standard truck loadings, a system of equivalent lane loadings was developed in order to provide a simple method of calculating bridge response to a series, or “train” of trucks. Lane loading consists of a uniform load per linear foot of traffic lane combined with a concentrated truck load located on the span to produce the most critical situation in the structure (see Figure 5.1.5).

For design and load capacity rating analysis, make an investigation of both a truck loading and a lane loading to determine which produces the greatest stress for each particular member. Lane loading will generally govern over truck loading for longer spans. Both the H and HS loadings have corresponding lane loads.



\* Use two concentrated loads for negative moment in continuous spans (Refer to *AASHTO LRFD Bridge Design Specifications 5<sup>th</sup> edition*, 2010 Interim; Article 3.6.1.2)

**Figure 5.1.5** AASHTO Lane Loadings

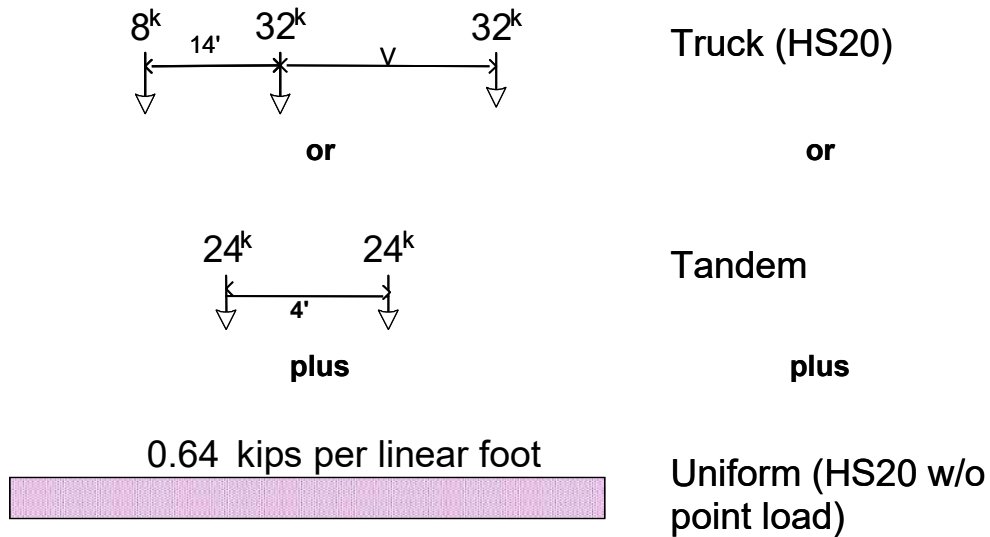
### LRFD Live Loads

Under HS-20 loading as described earlier, the truck or lane load is applied to each loaded lane. Under HL-93 loading, the design truck or tandem is combined with the lane load and applied to each loaded lane.

The LRFD design truck is exactly the same as the AASHTO HS-20 design truck. The LRFD design tandem, on the other hand, consists of a pair of 25 kip axles spaced 4 feet apart. The transverse wheel spacing of all of the trucks is 6 feet.

The magnitude of the HL-93 lane load is equal to that of the HS-20 lane load. The lane load is 0.64 kips per linear foot longitudinally and it is distributed uniformly over a 10 foot width in the transverse direction. The difference between the HL-93 lane load and the HS-20 lane load is that the HL-93 lane load does not include a point load. The HL-93 design load consists of a combination of the design truck or design tandem, and design lane load (see Figure 5.1.6).

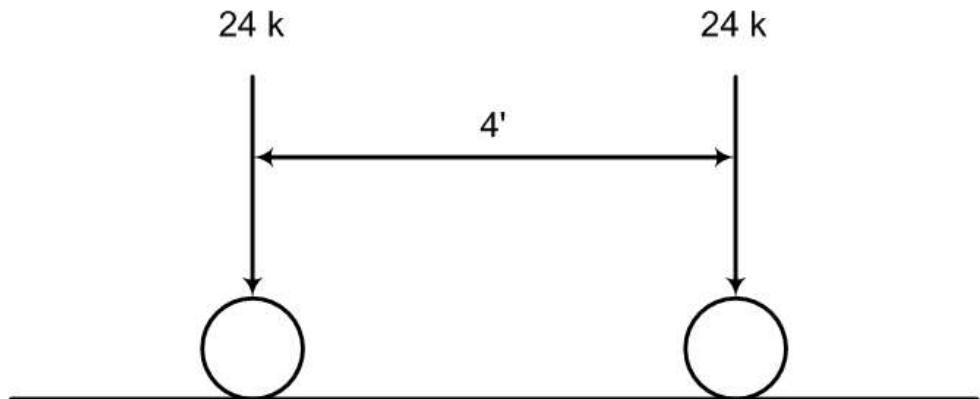
Finally, for LRFD live loading, the dynamic load allowance, or impact, is applied to the design truck or tandem but is not applied to the design lane load. It is typically 33 percent of the design vehicle.



**Figure 5.1.6** AASHTO LRFD Loading

**Alternate Military Loading**

The Alternate Military Loading is a single unit vehicle with two axles spaced at 4 feet and weighing 12 tons (or 24 kips) each. It has been part of the AASHTO *Specifications* since 1977. Bridges on interstate highways or other highways which are potential defense routes are designed for whichever produces the greatest stress (see Figure 5.1.7).



**Figure 5.1.7** Alternate Military Loading

### Permit Vehicles

Permit vehicles are overweight vehicles which, in order to travel a state's highways, must apply for a permit from that state. They are usually heavy trucks (e.g., combination trucks, construction vehicles, or cranes) that have varying axle weights and spacings depending upon the design of the individual truck. To ensure that these vehicles can safely operate on existing highways and bridges, most states require that bridges be designed for a permit vehicle or that the bridge be checked to determine if it can carry a specific type of vehicle. For safe and legal operation, agencies issue permits upon request that identify the required gross weight, number of axles, axle spacing, and maximum axle weights for a designated route (see Figure 5.1.8).



**Figure 5.1.8** Permit Vehicle

## Secondary Transient Loads

In bridge applications, the transient loads are temporary dynamic loads and can consist of the following:

- **Vehicular braking force** - a force in the direction of the bridge caused by braking of live load vehicles
- **Vehicular centrifugal force** - an outward force that a live load vehicle exerts on a curved bridge
- **Vehicular collision force** – the force caused by the collision of a vehicle into either the superstructure or substructure of a bridge
- **Vessel collision force** – the force caused by the collision of a water vessel into either the superstructure or substructure of a bridge
- **Earthquake load** - bridge structures are built so that motion during an earthquake will not cause a collapse
- **Friction load** – a force that is due to friction based upon the friction coefficient between the sliding surfaces
- **Ice load** - a horizontal force created by static or floating ice jammed against bridge components
- **Vehicular dynamic load allowance** – loads that account for vibrations and resonance between bridge, live load, and vibrations due to surface discontinuities (i.e. deck joints, potholes, cracks)
- **Vehicular live load** – AASHTO standard live loads placed upon the bridge due to vehicles
- **Live load surcharge** – a load where vehicular live load is expected on the surface of backfill within a distance to one-half the wall height behind the back face of the wall
- **Pedestrian live load** – AASHTO standard live load placed upon a bridge due to pedestrians which include sidewalks and other structures
- **Forces effect due to settlement** - a horizontal force acting on earth-retaining substructure units, such as abutments and retaining walls
- **Temperature** - since materials expand as temperature increases and contract as temperature decreases, the force caused by these dimensional changes must be considered
- **Water load** - a horizontal force acting on bridge components constructed in flowing water
- **Wind load on live load** - wind effects transferred through the live load vehicles crossing the bridge
- **Wind load on structure** - wind pressure on the exposed area of a bridge

A bridge may be subjected to several of these loads simultaneously. AASHTO LRFD *Specifications* have established a table of Load Combination Limit States. For each Limit State, a set of load combinations are considered with a load factor to be applied to each particular load.

### 5.1.3

#### Bridge Response to Loadings

Each member of a bridge is intended to respond to loads in a particular way. It is important to understand the manner in which loads are applied to each member in order to evaluate if it functions as intended. Once the inspector understands a bridge member's response to loadings, the inspector will be able to determine if a member defect has an adverse effect on the load-carrying capacity of that member.

Bridge members respond to various loadings by resisting four basic types of forces. These are:

- Axial forces (compression and tension)
- Bending forces (flexure)
- Shear forces
- Torsional forces

#### Equilibrium

In calculating these forces, the analysis is governed by equations of equilibrium. Equilibrium equations represent a balanced force system and may be expressed as:

$$\begin{aligned}\sum V &= 0 \\ \sum H &= 0 \\ \sum M &= 0\end{aligned}$$

where:  $\Sigma$  = summation of  
V = vertical forces  
H = horizontal forces  
M = moments (bending forces)

#### Axial Forces

An axial force is a push or pull type of force which acts parallel to the longitudinal axis of a member. An axial force causes compression if it is pushing and tension if it is pulling (see Figure 5.1.9). Axial forces are generally expressed in English units of pounds or kips.

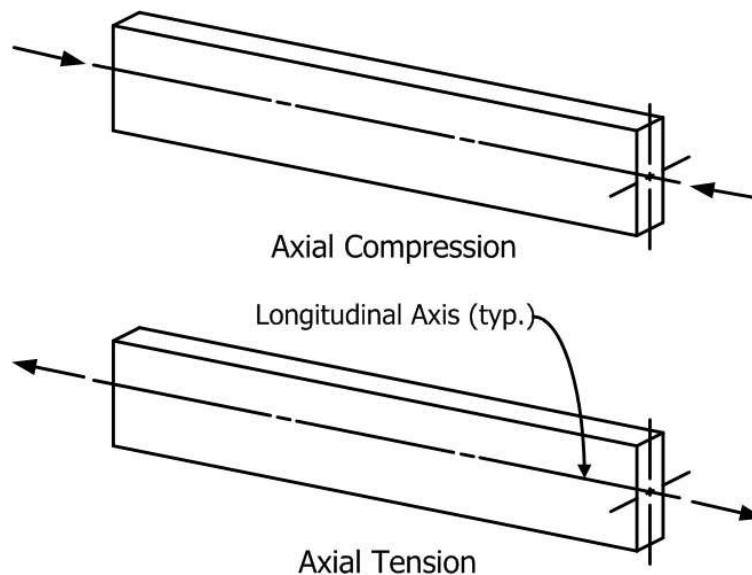


Figure 5.1.9 Axial Forces

**Examples of axial forces:** A man sitting on top of a fence post is exerting an axial force that causes compression in the fence post. A group of people playing tug-of-war exerts an axial force that causes tension in the rope.

Truss members are common bridge elements which carry axial loads. They are designed for either compression or tension forces. Cables are designed for axial forces in tension.

True axial forces act uniformly over a cross-sectional area. Therefore, axial stress can be calculated by dividing the force by the area on which it acts.

$$f_a = \frac{P}{A}$$

where:  $f_a$  = axial stress (kips per square inch)  
 $P$  = axial force (kips)  
 $A$  = cross-sectional area (square inches)

When bridge members are designed to resist axial forces, the cross-sectional area will vary depending on the magnitude of the force, whether the force is tensile or compressive, and the type of material used.

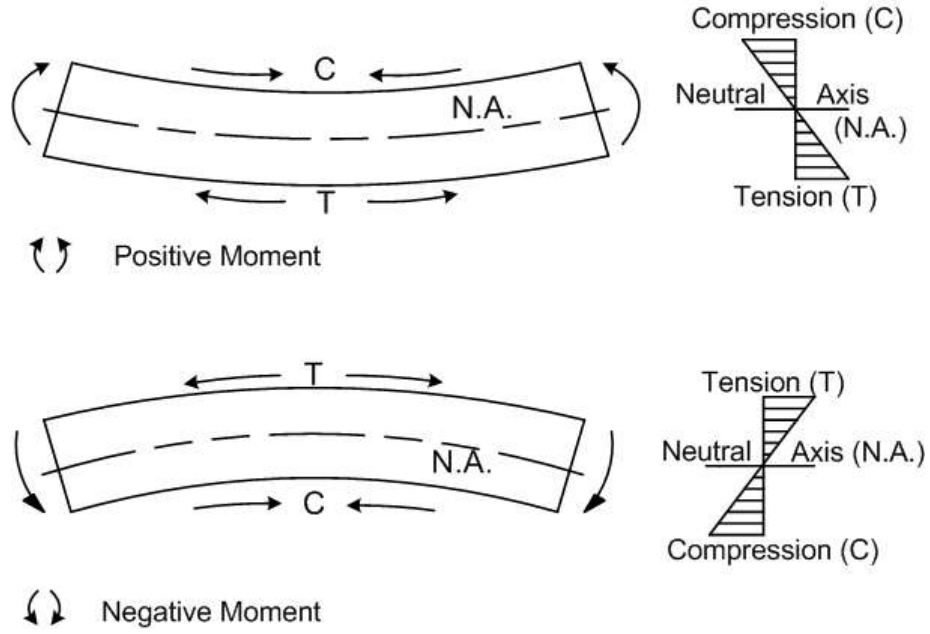
For tension and compression members, the cross-sectional area has to satisfy the previous equation for an acceptable axial stress. However, the acceptable axial compressive stress is generally lower than that for tension because of a phenomenon called buckling.

## Bending Forces

Bending forces in bridge members are caused when a load is applied perpendicular to the longitudinal or neutral axis. A moment is commonly developed by the perpendicular loading which causes a member to bend. The greatest bending moment that a beam can resist is generally the governing factor which determines the size and material of the member. Bending moments can be positive or negative and produce both compression and tension forces at different locations in the member (see Figure 5.1.10). Moments are generally expressed in English units of pound-feet or kip-feet.

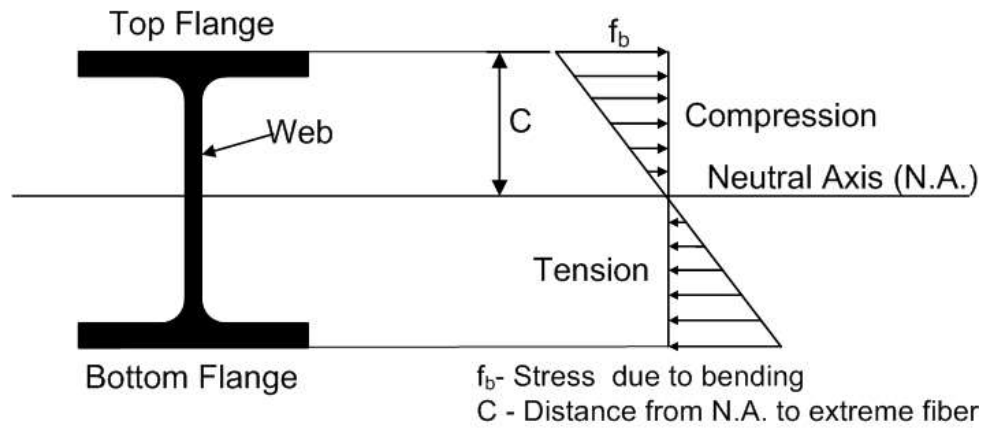
**Example of bending moment:** When a rectangular rubber eraser is bent, a moment is produced in the eraser. If the ends are bent upwards, the top half of the eraser can be seen to shorten, while the bottom half can be seen to lengthen. Therefore, the moment produces compression forces in the top layers of the eraser and tension forces in the bottom layers.





**Figure 5.1.10** Positive and Negative Moment

Beams and girders are the most common bridge elements used to resist bending moments. The flanges are most critical because they provide the greatest resistance to the compressive and tensile forces developed by the moment (see Figure 5.1.11).



**Figure 5.1.11** Girder Cross Section Resisting Positive Moment

Bending stress is normally considered zero at the neutral axis. On a cross section of a member, bending stresses vary linearly with respect to the distance from the neutral axis (see Figures 5.1.10 and 5.1.11).

The formula for maximum bending stress is (see Figure 5.1.11):

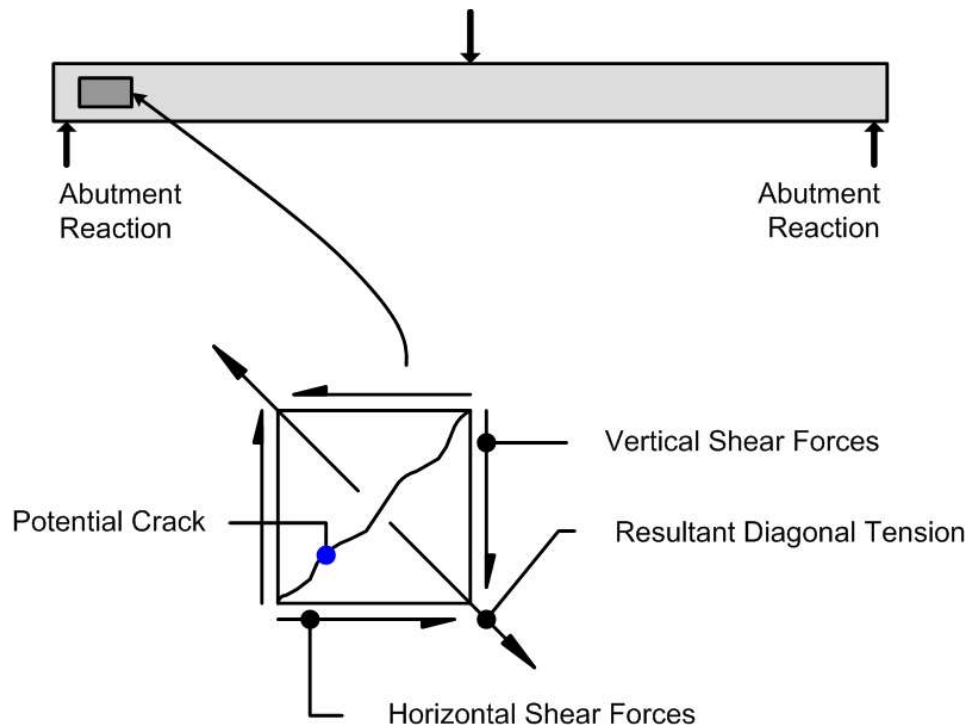
$$f_b = \frac{Mc}{I}$$

- where:
- $f_b$  = bending stress on extreme fiber (or surface) of beam (kips per square inch)
  - $M$  = applied moment (inch · lbf)
  - $c$  = distance from neutral axis to extreme fiber (or surface) of beam (inches)
  - $I$  = moment of inertia (a property of the beam cross-sectional area and shape) (lbf · square inch)

### Shear Forces

Shear is a force, which results from equal but opposite transverse forces, which tend to slide one section of a member past an adjacent section (see Figure 5.1.12). Shear forces are generally expressed in English units of pounds or kips.

**Example of shear:** When scissors are used to cut a piece of paper, a shear force has caused one side of the paper to separate from the other. Scissors are often referred to as shears since they exert a shear force.



**Figure 5.1.12** Shear Forces in a Member Element

Beams and girders are common shear resisting members. In an I- or T-beam, most of the shear is resisted by the web (see Figures 5.1.11 and 5.1.12). The shear